

CHAYSOL 

VCR-VCR-T Series



**IN-LINE DUCT FANS
RECTANGULAR DUCT FANS**

IN-LINE DUCT FANS VCR / VCR-T, RECTANGULAR DUCT FANS



DESCRIPTION

The VCR / VCR-T range of centrifugal low pressure fans are specifically designed to be installed within rectangular ducted ventilation systems or where the space for installation is limited. The range comprises of eight nominal model sizes, covering 23 models in total. The range is available with single 230V 50Hz, or three phase 230/400V 50z motors in 4, 6 and 8 pole speeds.

Air volume performance ranges from 1,090 up to 10,235 m³/hr.

All models are suitable for mounting in any orientation and operation within ambient air temperatures between -40° C up to +70° C.

APPLICATIONS

The Direct-Air ILT/ILB range are suitable for many general ventilation applications where the fan is required to be installed within a rectangular ducted ventilation system or where the space for installation is limited. Due to the configuration of the design, the dimension of the fan section would be no greater than that of the proposed nominal ducting. Typical installations would include:

- Commercial offices air extract / supply.
- Car park supply air
- Restaurants
- Installations where the mounting space is limited or confined

CONSTRUCTION

Casing

The fan casings are manufactured from heavy gauge galvanised sheet steel. All models incorporate an inspection cover that can be removed to access the motor / impeller assembly without having to remove the complete fan casing from the ducting.

Motor / Impeller

All models incorporate direct-drive low pressure forward curved centrifugal impellers.

The impeller is factory matched to the motor and the complete assembly is dynamically balanced to ISO 1940 standards.

Motors

All models incorporate asynchronous induction motors with squirrel cage rotor in die cast aluminium. Manufactured in accordance with IEC 34-1 standard.

The following specifications apply.

- Single Phase 230V 50Hz.
- Three Phase 230/400V 50Hz.

- IP55 protection.
- Class F insulation.
- Thermal Overload Protection.
- Sealed For Life, ball bearing assemblies.
- Remote mounting wiring outlet box. (800mm lead length).

All models, both single and three phase, are suitable for speed control regulation using auto-transformer type RMB-RMT products.

Before installation, it is important to check that the product electrical characteristics listed on the data plate label (voltage, power, frequency etc), match those of the intended electrical supply.

TECHNICAL CHARACTERISTICS

Model Type	Nominal ducting dimensions (mm)	Nom. speed (r.p.m.)	Maximum absorbed power (W)	Maximum absorbed current (A)		Maximum air volume (m ³ /h)	Sound pressure level (dB(A))	Weight (kg)
				230 V	400 V			
4 POLE SINGLE PHASE								
VCR/4-200	400 x 200	1240	240	1,15	-	1090	57	15
VCR/4-225	500 x 250	1130	520	2,45	-	1670	65	20
VCR/4-250	500 x 300	1130	950	4,40	-	2350	66	25
6 POLE SINGLE PHASE								
VCR/6-225	500 x 250	800	200	1,00	-	1080	56	20
VCR/6-250	500 x 300	800	310	1,50	-	1500	57	25
VCR/6-285	600 x 300	825	660	3,20	-	2650	62	32
VCR/6-315	600 x 350	810	710	3,40	-	2780	62	40
VCR/6-355	700 x 400	800	1300	6,30	-	4070	64	60
4 POLE THREE PHASE								
VCR-T/4-200	400 x 200	1270	260	0,90	0,52	1150	57	15
VCR-T/4-225	500 x 250	1160	500	1,70	0,98	1700	65	20
VCR-T/4-250	500 x 300	1170	930	3,00	1,77	2650	66	25
VCR-T/4-285	600 x 300	1070	1260	4,15	2,40	3100	68	32
VCR-T/4-315	600 x 350	1390	2440	8,00	4,60	4160	70	42
6 POLE THREE PHASE								
VCR-T/6-225	500 x 250	840	220	1,00	0,57	1185	56	20
VCR-T/6-250	500 x 300	800	280	1,00	0,57	1630	57	25
VCR-T/6-285	600 x 300	840	670	2,30	1,33	2700	62	32
VCR-T/6-315	600 x 350	900	710	2,50	1,44	2820	62	40
VCR-T/6-355	700 x 400	875	1380	5,20	3,00	4200	64	65
VCR-T/6-400	800 x 500	950	3000	11,00	6,37	7400	69	80
VCR-T/6-450	1000 x 500	900	5350	17,30	10,00	10850	71	100
8 POLE THREE PHASE								
VCR-T/8-355	700 x 400	660	614	2,31	1,33	3030	56	65
VCR-T/8-400	800 x 500	710	1340	4,93	2,84	5350	63	80
VCR-T/8-450	1000 x 500	675	2380	7,71	4,45	8000	65	100

*Measured at 1.0m with ducted inlet and outlet.



PERFORMANCE CURVES

- Q = Air volume in, m³/hr and m³/s
- Pe = Static pressure in mmWG and Pa.
- Dry air at 20 °C and 760 mmHg.
- Air flow data in accordance with the following standards: UNE 100-212-89, BS 848, Part 1, AMCA 210-85 and ASHRAE 51-1985.

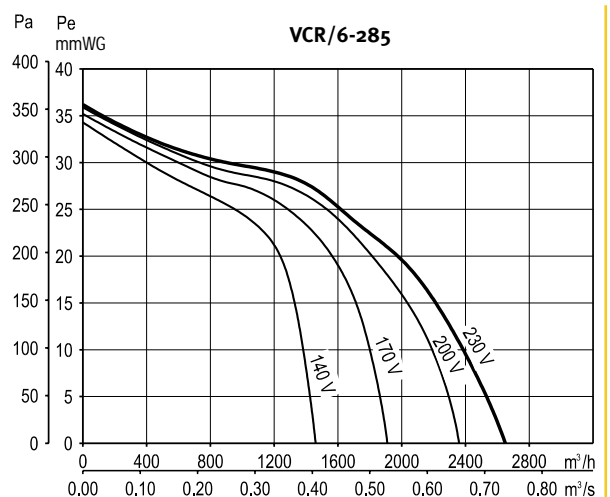
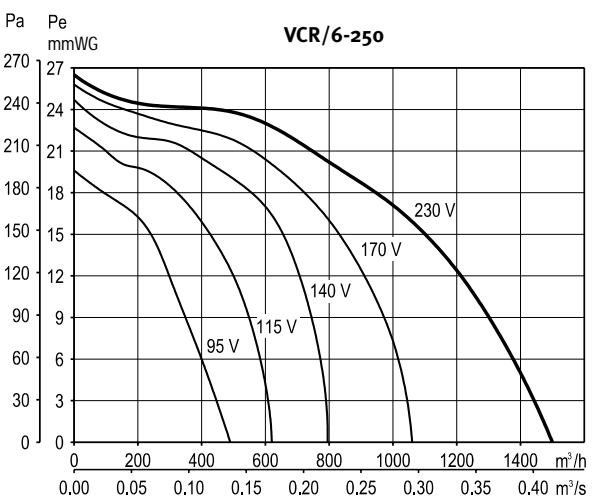
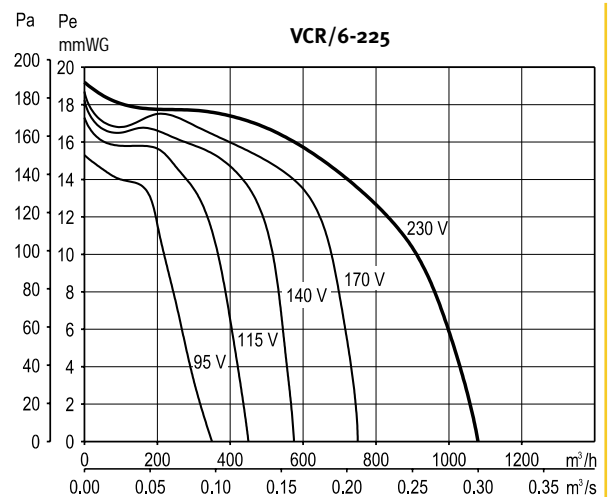
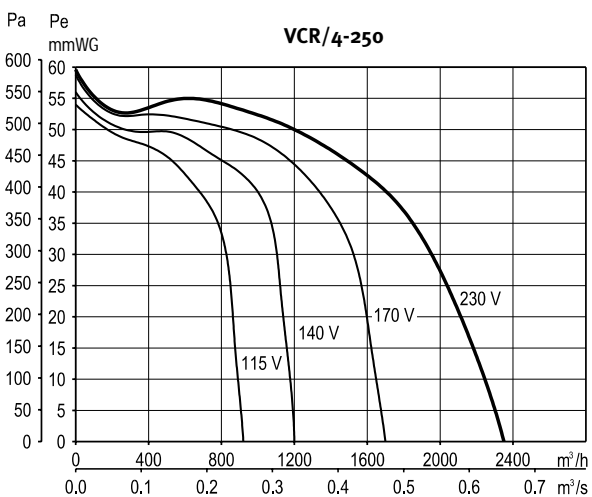
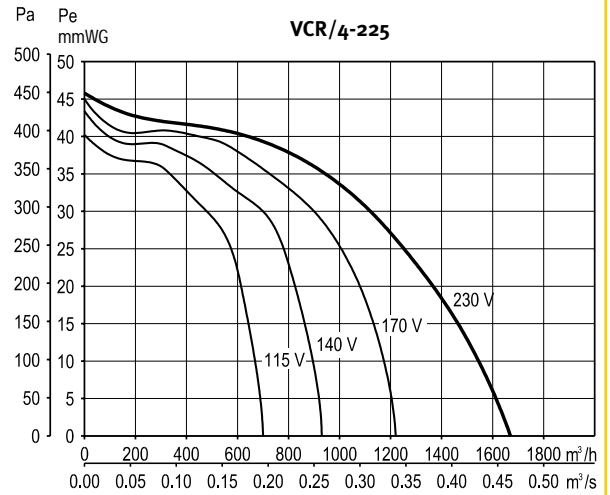
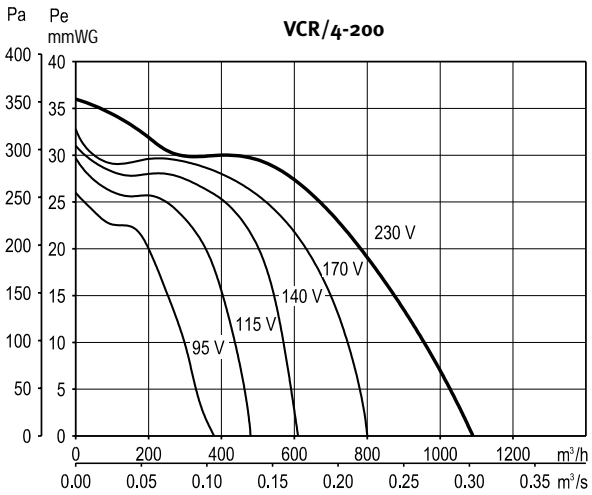

The curves shown represent different performances obtained using an RMB-RMT auto-transformer speed control at different speed settings.



PERFORMANCE CURVES

- Q = Air volume in, m³/hr and m³/s
- Pe = Static pressure in mmWG and Pa.
- Dry air at 20 °C and 760 mmHg.
- Air flow data in accordance with the following standards: UNE 100-212-89, BS 848, Part 1, AMCA 210-85 and ASHRAE 51-1985.

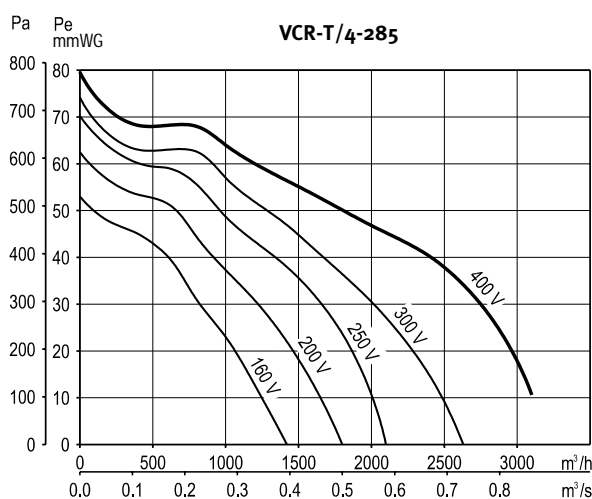
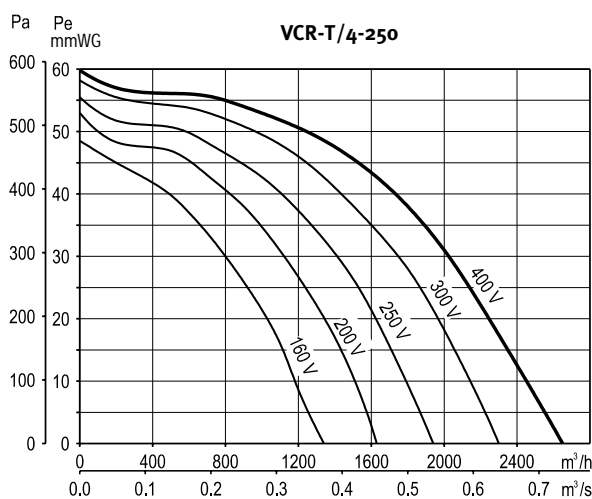
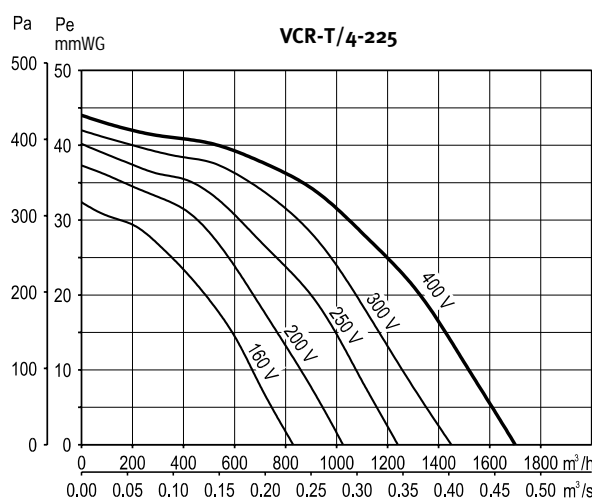
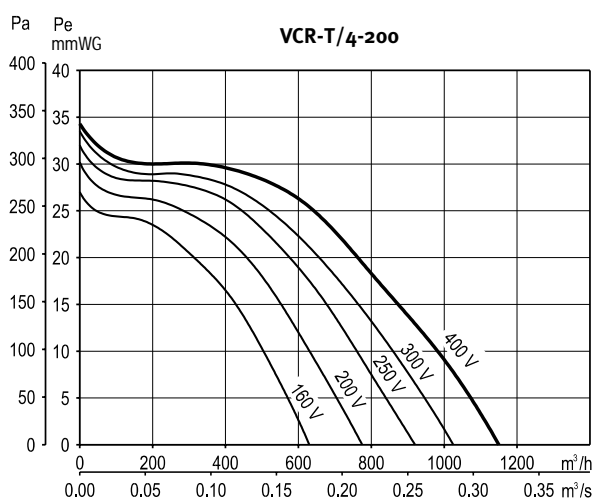
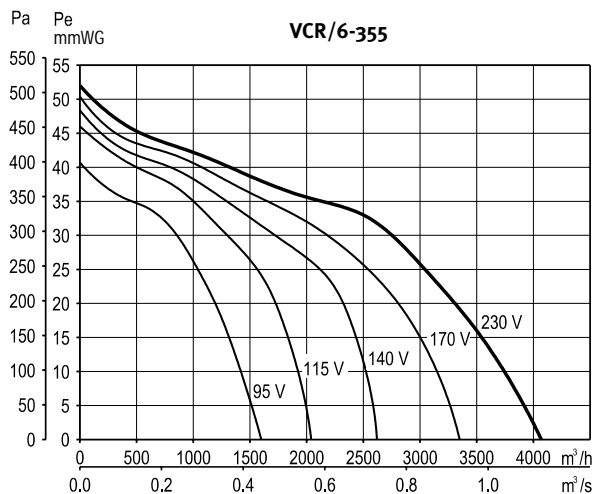
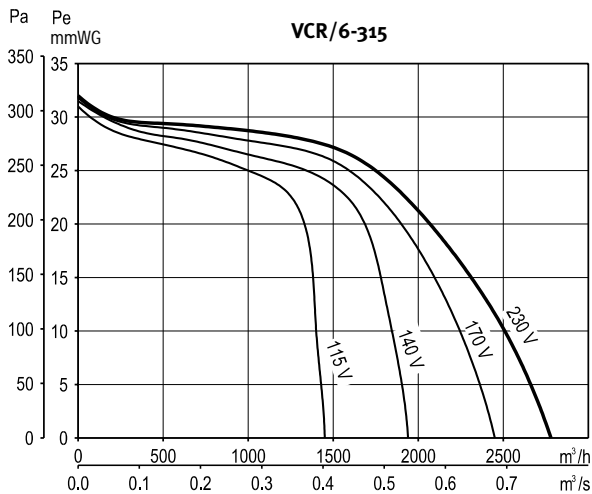

The curves shown represent different performances obtained using an RMB-RMT auto-transformer speed control at different speed settings.



PERFORMANCE CURVES

- Q = Air volume in, m³/hr and m³/s
- Pe = Static pressure in mmWG and Pa.
- Dry air at 20 °C and 760 mmHg.
- Air flow data in accordance with the following standards: UNE 100-212-89, BS 848, Part 1, AMCA 210-85 and ASHRAE 51-1985.

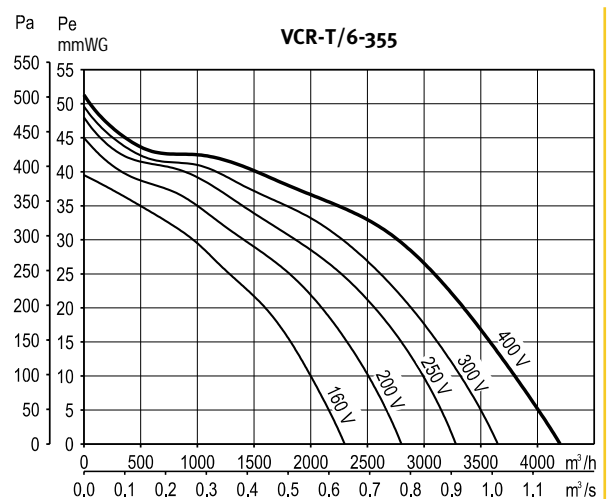
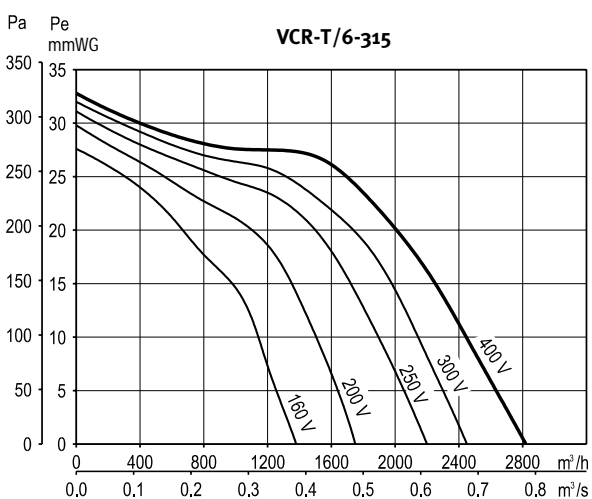
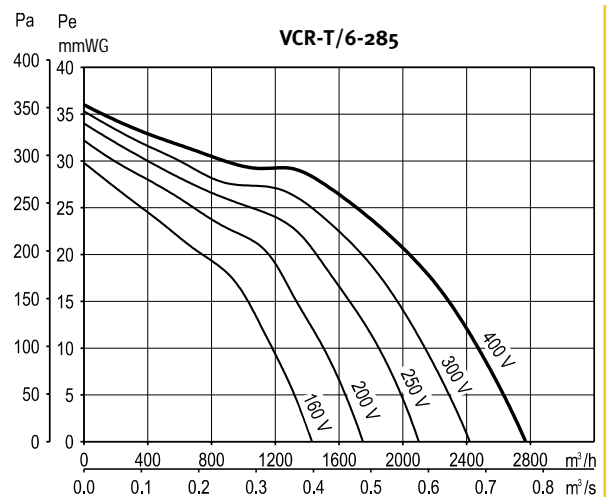
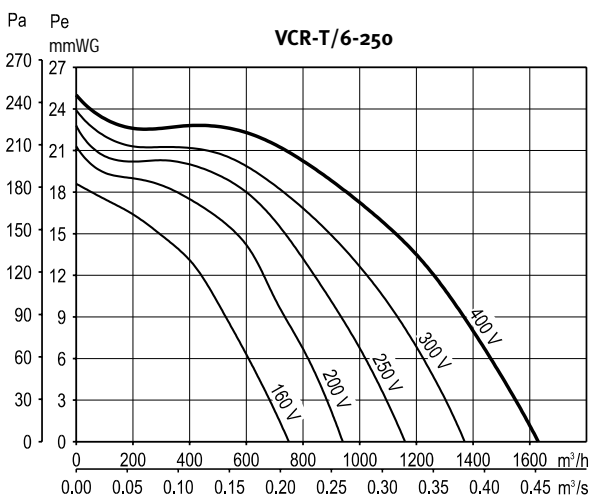
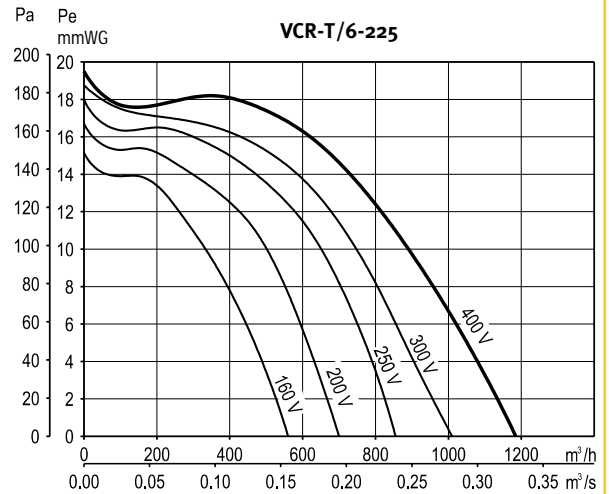
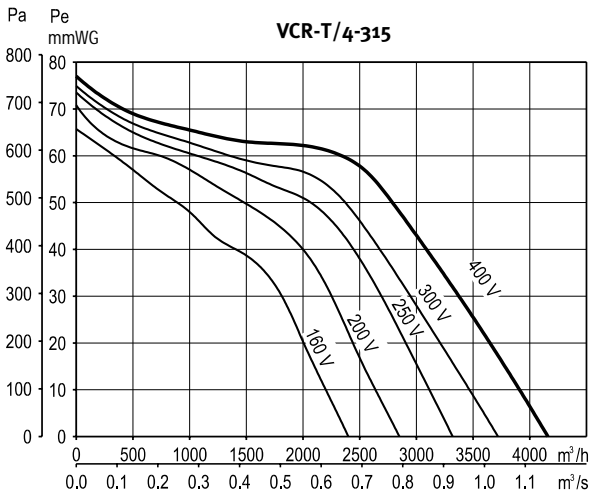

The curves shown represent different performances obtained using an RMB-RMT auto-transformer speed control at different speed settings.



PERFORMANCE CURVES

- Q = Air volume in, m³/hr and m³/s
- Pe = Static pressure in mmWG and Pa.
- Dry air at 20 °C and 760 mmHg.
- Air flow data in accordance with the following standards: UNE 100-212-89, BS 848, Part 1, AMCA 210-85 and ASHRAE 51-1985.

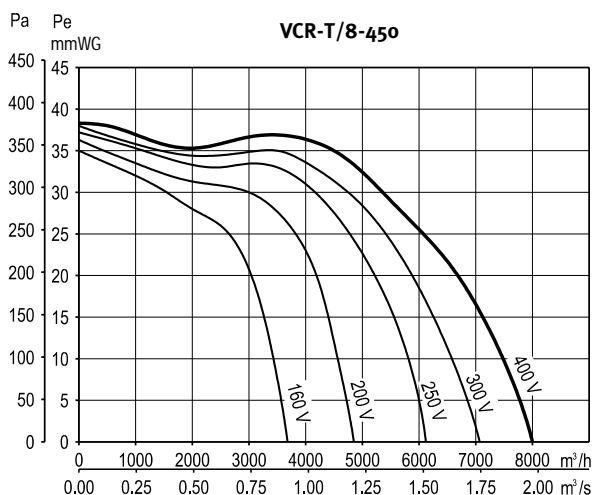
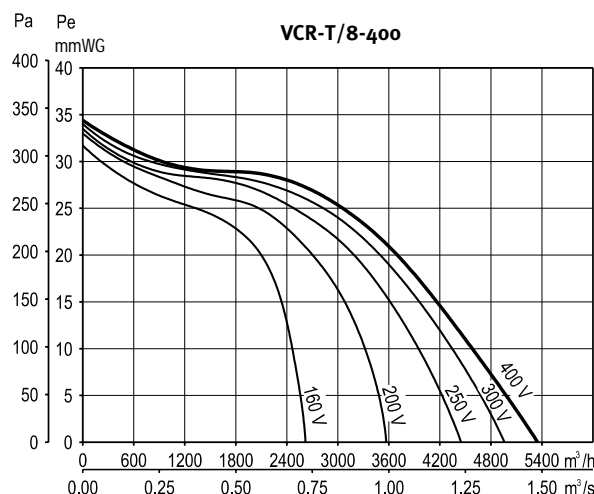
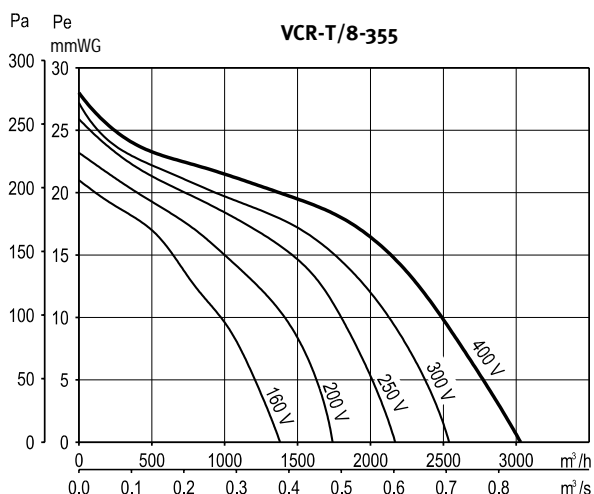
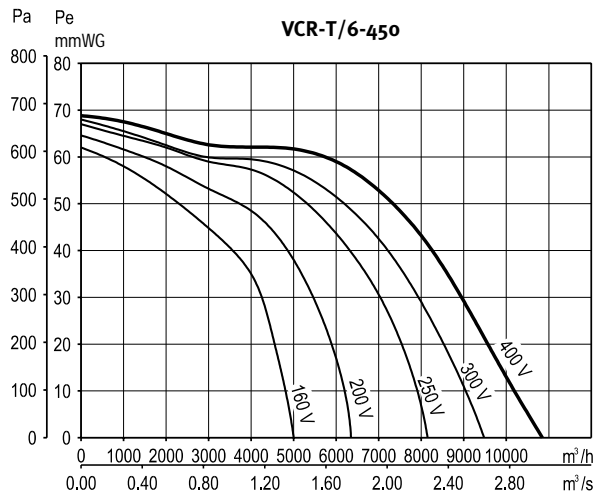
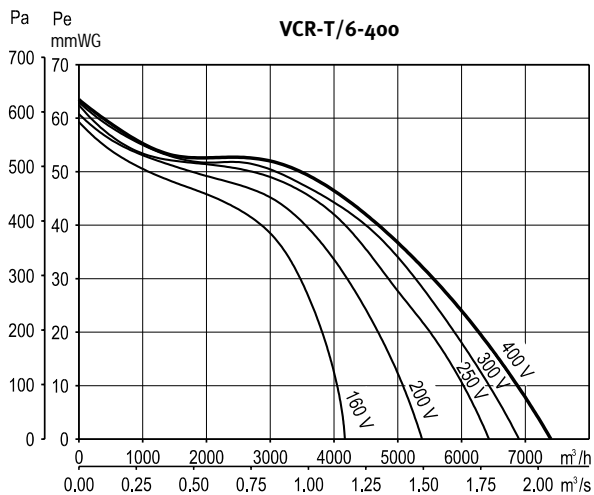

The curves shown represent different performances obtained using an RMB-RMT auto-transformer speed control at different speed settings.



ACOUSTIC CHARACTERISTICS

Radiated Sound Power Level (LwA)

Radiated Sound Power Level Spectrum (LwA) at the corresponding octave band averages (Hz).

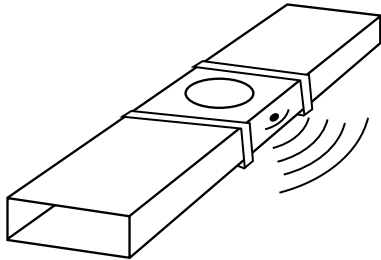

Model Type	125	250	500	1000	2000	4000	8000
4-200	63,0	64,0	62,0	57,5	50,0	43,5	33,0
4-225	69,5	73,0	70,5	64,0	58,0	50,0	40,0
6-225	63,0	66,0	63,5	57,0	51,0	43,0	33,0
4-250	72,5	71,0	70,0	65,5	60,5	53,0	44,0
6-250	63,5	62,0	61,5	56,5	51,5	44,0	35,0
4-285	73,5	74,0	73,5	66,0	62,0	53,0	43,0
6-285	67,5	68,0	67,5	60,5	56,0	47,5	37,5
4-315	77,5	74,0	74,5	72,0	70,0	61,5	49,0
6-315	68,0	64,0	65,0	62,0	60,5	52,0	39,5
6-355	70,5	69,0	70,0	63,5	61,5	51,0	41,0
8-355	62,0	60,0	61,5	55,0	52,5	42,5	32,5
6-400	75,0	74,0	74,0	70,0	66,5	57,5	46,0
8-400	69,0	67,5	68,0	63,5	60,5	49,5	40,0
6-450	78,0	76,5	76,0	71,5	69,5	58,0	48,5
8-450	72,0	70,5	70,0	65,5	63,5	52,0	42,5

In-Duct Sound Power Level (LwA)

In-Duct Sound Power Level Spectrum (LwA) at the corresponding octave band averages (Hz).

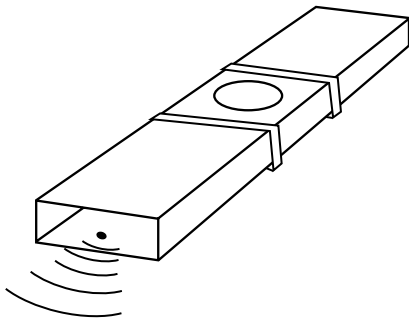

Model Type	125	250	500	1000	2000	4000	8000
4-200	63,0	66,0	70,0	71,5	70,0	69,5	61,5
4-225	69,5	74,5	78,5	78,0	77,5	76,0	68,0
6-225	62,5	67,5	71,5	71,0	70,5	69,0	61,0
4-250	72,5	74,0	79,5	80,5	81,5	80,0	73,0
6-250	63,5	65,5	70,5	72,0	73,0	71,0	64,5
4-285	73,5	77,0	82,0	81,0	83,0	80,0	72,0
6-285	67,5	71,0	76,5	75,0	77,0	74,0	66,0
4-315	79,5	82,6	87,5	89,5	91,5	89,5	82,0
6-315	70,0	73,0	78,0	80,0	82,0	80,0	72,5
6-355	72,5	78,0	84,0	83,0	84,5	81,0	73,0
8-355	64,0	69,5	75,5	74,0	76,0	72,5	64,5
6-400	77,5	83,5	88,5	89,0	90,0	86,0	78,5
8-400	71,0	77,0	82,5	83,0	84,0	80,0	72,0
6-450	80,5	86,0	90,5	91,0	93,0	88,5	81,0
8-450	74,5	80,0	84,5	85,0	87,0	82,5	75,0

DIMENSIONS (mm)

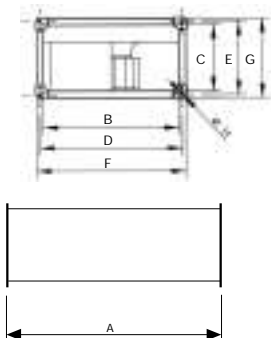

Model Type	A	B	C	D	E	F	G	Ø H
200	505	400	198	440	220	440	240	9
225	535	500	248	520	270	540	290	9
250	565	500	298	520	320	540	340	9
285	645	600	298	620	320	640	340	9
315	725	600	348	620	370	640	390	9
355	785	700	398	720	420	740	440	9
400	885	800	498	820	520	840	540	9
450	985	1000	498	1020	520	1040	540	9



ACCESSORIES – FILTERS AND ELECTRIC HEATERS



FB-VR, Filter Box

For supply air applications a comprehensive range heavy duty bag filters (FB-VR) are offered with type EU5 grade filtration mounted within a rectangular ducting casing. All FB-VR filters casings incorporate an access door to permit filter replacement without having to remove the complete casing from the ducting.

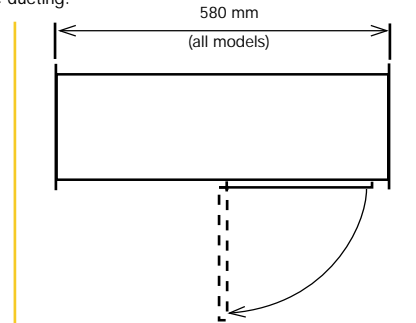
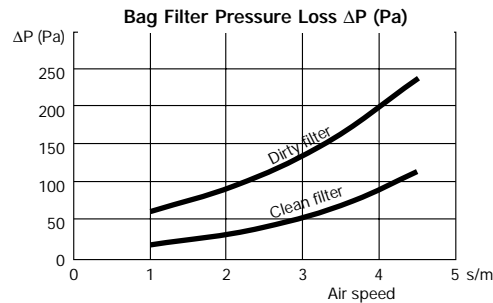

EB-VR, Electric Batterie

The EB-VR range of electric heater battery sections are designed to be installed on the discharge side of the CVR / CVR-T fans. The units incorporate insulated (black heat) element rods ($230V - 3W/cm^2$) with an automatic integrated thermostat (set at $90^\circ C$). This thermostat in turn is wired in series with an additional safety overheat manual reset thermostat (set at $120^\circ C$). In the case of the unit overheating the second thermostat will switch the unit off, after which the heater can then be "Reset" manually via the push button switch. All wiring terminations and connections are located on the side of the heater casing.

All models require 3 x 400V connection to the electrical supply and appropriate circuit protection.

- The units are supplied with an IP43 rated wiring enclosure.
- The minimum air velocity through the heater batteries must ≥ 2 m/s.
- The maximum output temperature, from the discharge, is $60^\circ C$.

To compliment the IBE electric heaters a range of controllers are available which modulate the heater output as a function of the required environmental temperature (see Electrical Accessories section of this catalogue).

EXAMPLE - HEATER BATTERY SELECTION

DATA:

- Required air volume: $3,300 m^3/hr (Q)$
- Temp. of air entering: $-5^\circ C$
- Temp. required at discharge: $+20^\circ C$

HEATER BATTERY POWER REQUIRED:

$$P = Q \times 0,36 \times \Delta T$$

$$= 3300 \times 0,36 \times [20 - (-5)]$$

$$= 29,700 W$$

$$= 29,7 kW$$

SELECTION OF HEATER:

EB-VR-315/30T or
EB-VR-355/30T

The final selection depends upon:

- Available height
- Total system pressure loss
- Sound level

Fan type CVR/CVR-T	Electric batterie type	Heater power output (kW)	Heater element subdivisions (kW)	Minimum air volume (m^3/h)	Wiring diagram	Controller type REG
200	EB-VR-200/9T	9	3 x 3	580	E30	REG 16
225	EB-VR-225/16,5T	16,5	3 x 5,5	900	E40	REG 16
250	EB-VR-250/16,5T	16,5	3 x 5,5	1100	E40	REG 16
285	EB-VR-285/20T	20	3 x 6,7	1300	E50	REG 16 + RA
315	EB-VR-315/30T	30	6,8+6,8+8,2+8,2	1500	E60	REG 16 + RA
355	EB-VR-355/30T	30	6,8+6,8+8,2+8,2	2000	E60	REG 16 + RA
400	EB-VR-400/50T	50	3 x 16,7	2400	E70	-
450	EB-VR-450/63T	63	3 x 21	3600	E70	-

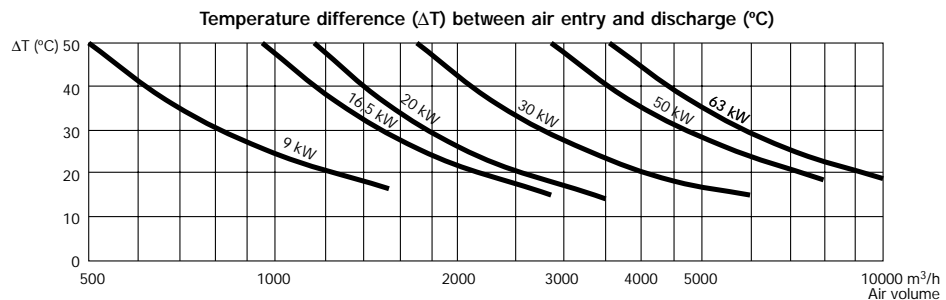

Type	B	C
200	400	198
225	500	248
250	500	298
285	600	298
315	600	348
355	700	398
400	800	498
450	1000	498

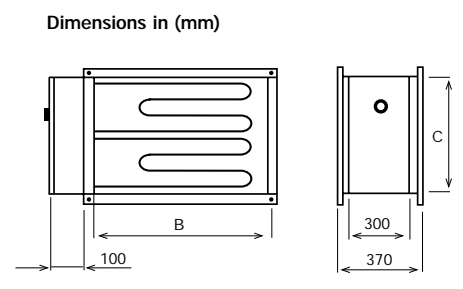
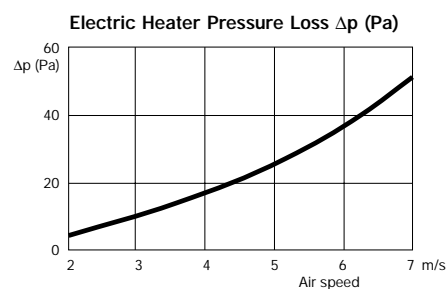



INSTALLATION ACCESSORIES



AA-VR, Acoustic Attenuator

- The AA-VR range of acoustic attenuators designed to reduce in-duct sound levels
- All models are supplied with sound absorbing material (MO) and manufactured in 1m lengths.

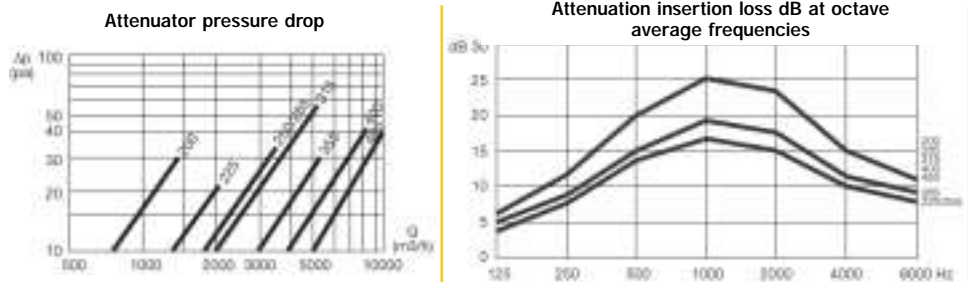

AS-VR

Antivibrator support

1 AS-VR = 4 supports



EJ-VR

Elastic joint



GR-VR

Grill



FL-VR

Flange

SUMMARY Accessories for VCR / VCR-T FANS

Fan Type VCR / VCR-T	Antivibrator support	Flange	Filter box	Elastic joint	Acoustic attenuator	Grill
200	AS-VR	FL-VR - 200	FB-VR - 200	EJ-VR - 200	AA-VR - 200	GR-VR - 400 x 200
225	AS-VR	FL-VR - 225	FB-VR - 225	EJ-VR - 225	AA-VR - 225	GR-VR - 500 x 250
250	AS-VR	FL-VR - 250	FB-VR - 250	EJ-VR - 250	AA-VR - 250	GR-VR - 500 x 300
285	AS-VR	FL-VR - 285	FB-VR - 285	EJ-VR - 285	AA-VR - 285	GR-VR - 600 x 300
315	AS-VR	FL-VR - 315	FB-VR - 315	EJ-VR - 315	AA-VR - 315	GR-VR - 600 x 350
355	AS-VR	FL-VR - 355	FB-VR - 355	EJ-VR - 355	AA-VR - 355	GR-VR - 700 x 400
400	AS-VR	FL-VR - 400	FB-VR - 400	EJ-VR - 400	AA-VR - 400	GR-VR - 800 x 500
450	AS-VR	FL-VR - 450	FB-VR - 450	EJ-VR - 450	AA-VR - 450	GR-VR - 1000 x 500

ELECTRICAL ACCESSORIES



SRS - Speed regulator
Single phase

SRT - Speed regulator
Three phase

Fan speed control
regulators.



BR 16

BR 16 + RA

Batterie regulators

The BR 16 + RA type
controller requires a
temperature test for
operation.



TSD Temperature
sonde duct

TSA Temperature
sonde ambiance

Temperature tests.



WIRING DIAGRAMS FOR TYPE MBE AND IBE ELECTRIC HEATER BATTERIES

WIRING DIAGRAM E20

ELECTRIC HEATER BATTERY TYPE: MBE-315/90T
EB-VR-200/9T

- A : HEATING ELEMENTS
- B : AUTO-RESET THERMAL PROTECTION STAT
- C : MANUAL-RESET THERMAL PROTECTION STAT
- D : BR 6 (Max. 6 kW 400V)
- E : SWITCH
- F : ELECTRICAL CONTACTORS
- G : ELECTRICAL LINE PROTECTION
- H : TEMPERATURE TEST (type TSD or TSA, optional)

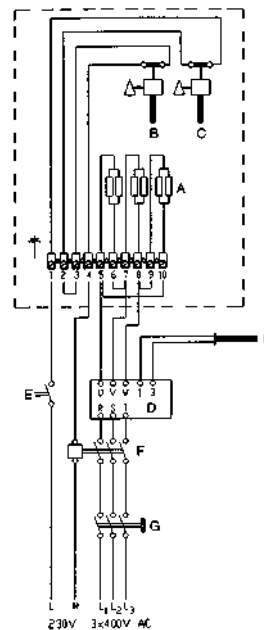

WIRING DIAGRAM E40

ELECTRIC HEATER BATTERY TYPE: EB-VR-225/16,5T
EB-VR-250/16,5T

- A : HEATING ELEMENTS
- B : AUTO-RESET THERMAL PROTECTION STAT
- C : MANUAL-RESET THERMAL PROTECTION STAT
- D : BR 6 (Max. 3,2 kW 230V)
- E : SWITCH
- F : ELECTRICAL CONTACTORS
- G : ELECTRICAL LINE PROTECTION
- H : TEMPERATURE TEST (type TSD or TSA, optional)

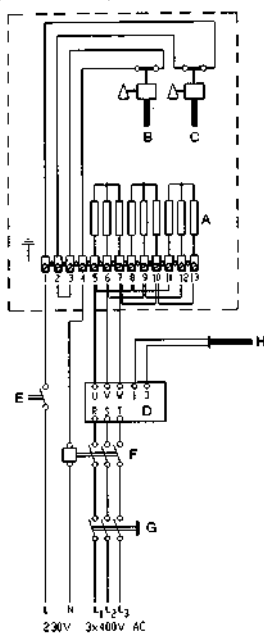

WIRING DIAGRAM E50

ELECTRIC HEATER BATTERY TYPE: EB-VR-285/20T

- A : HEATING ELEMENTS
- B : AUTO-RESET THERMAL PROTECTION STAT
- C : MANUAL-RESET THERMAL PROTECTION STAT
- D : BR 6 (Max. 16,5 kW 400V) + RA (Max. 70% of the load)
- E : SWITCH
- F : ELECTRICAL CONTACTORS
- G : ELECTRICAL LINE PROTECTION
- H : TEMPERATURE TEST (type TSD or TSA, optional)

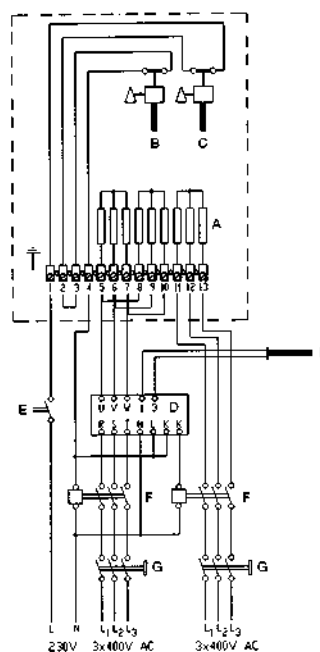



WIRING DIAGRAM E60

ELECTRIC HEATER BATTERY TYPE: EB-VR-315/30T
EB-VR-355/30T

- A : HEATING ELEMENTS
- B : AUTO-RESET THERMAL PROTECTION STAT
- C : MANUAL-RESET THERMAL PROTECTION STAT
- D : BR 6 (Max. 16,5 kW 400V) + RA (Max. 70% of the load del BR16)
- E : SWITCH
- F : ELECTRICAL CONTACTORS
- G : ELECTRICAL LINE PROTECTION
- H : TEMPERATURE TEST (type TSD or TSA, optional)

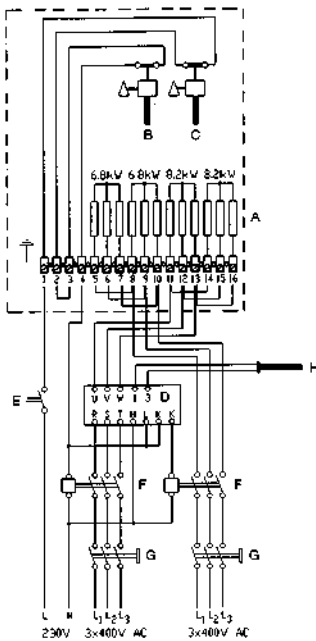

WIRING DIAGRAM E70

ELECTRIC HEATER BATTERY TYPE: EB-VR-400/50T
EB-VR-450/63T

- A : HEATING ELEMENTS
- B : AUTO-RESET THERMAL PROTECTION STAT
- C : MANUAL-RESET THERMAL PROTECTION STAT
- D : CONTROL UNIT (NOT SUPPLIED)
- E : SWITCH
- F : ELECTRICAL CONTACTORS
- G : ELECTRICAL LINE PROTECTION

