



HYDRAULIC CONTROL F3



CHARACTERISTICS

F3 hydraulic controls are devices which are generally coupled with pneumatic cylinders allowing to reach a refined adjustment of the working speed.

G.P.A. Italiana produces **26 standard types of hydraulic controls**. According to their function, they can be divided into:

HYDRAULIC CONTROL	ROD OUTLET	ROD REENTRY
Under tension	Controlled	Fast
On thrust	Fast	Controlled
D.A.F. (double braking action)	Controlled	Controlled

Schematically speaking, the **F3** control is a hydraulic circuit without any power source (picture 1). During the rod outlet the oil is pushed from A to B box through a connecting pipe and the adjusting valve (speed control). When the rod reenters, the oil freely gets from the B into the A box through the C check valve (fast). The S tank assures a quantity of oil under pressure enough to compensate both the difference in volume between the two A and B boxes, and the current oil leakages. The tank (picture 2) is linked to the rear flange of the hydraulic control by means of a connecting flask. Afterwards the tank position for each type of control will be indicated.

Three standard types of tank are produced.

Check periodically the L measuring stick of the tank indicating the maximum and minimum oil level (the level must be read when the measuring stick is fully inside).

In order to restore the level, unscrew the H safety cap (picture 2) and inject some oil by priming pump (picture 3).

On demand G.P.A. produces hydraulic controls with:

- 1) strokes over 500 mm.;
- 2) SKIP and STOP adjusting devices (pict.5/6/7/8) assembled on a plate, which are isolated from the hydraulic control and with operational diagrams which differ from the ones mentioned in this catalogue;
- 3) SKIP and STOP controls operated by solenoid valves;
- 4) tanks which are axially assembled or isolated from the hydraulic control.

TECHNICAL CHARACTERISTICS

Bore	= 35 mm.
Max. applicable force	= N 5.000 *
Min. speed	= 70 mm./min.
Max. speed	= 10.000 mm./min.
Max. temperature	= 80°C

CONSTRUCTIVE CHARACTERISTICS

Heads	= 11-S UNI 6362 oxidated black aluminium alloy
Liner	= aluminium
Rod	= chromium plated C 40 steel
Gaskets	= polyurethan and nitrilic rubber
Oil	= ESSO automatic transmission fluid or similar

* To operate properly, the thrust acting on the rod must be axial and without any radial components.

In case of hydraulic control working "On thrust" or "D.A.F." the applicable force is to be limited taking into account the combined bending and compressive load for the rod (\varnothing mm 12) according to the required stroke.

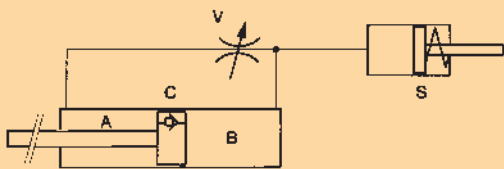

Fig. 1 - Diagram of the hydraulic control under tension

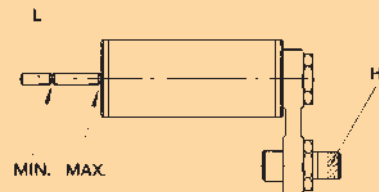

Fig. 2 - Tank and flask unit - Pos. 307



Fig. 3 - Priming pump



Fig. 4 - Two-way valve - Electric control - Pos. 308



NAMEPLATE AND CODE COMPOSITION

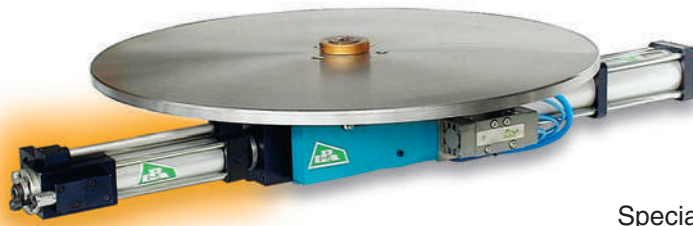

Special model for G.P.A. rotary table

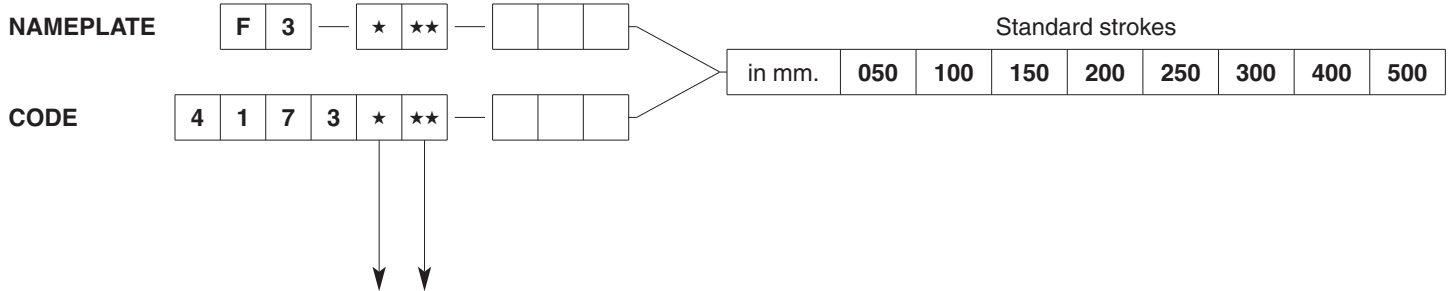

TYPE OF CONTROL

N.B. — The first number (*) indicates the type of control during the rod reentry. — The second number (**) indicates the type of control during the rod outlet.		
0	NOT CONTROLLED	The oil freely gets from one box into the other through the check valve which is placed in the piston
1	ADJUSTMENT	The oil gets from one box into the other through a needle valve with micrometric adjustment (picture 5)
2	ADJUSTMENT + SKIP	In parallel to adjustment 1 there is a normally open (***) pneumatic valve which lets the oil freely get from one box into the other (SKIP) (pict. 6)
3	ADJUSTMENT + STOP	In series to adjustment 1 there is a two-way normally open (***) pneumatic valve which can block oil passage from one box to the other (STOP) (pict. 7)
4	ADJUSTMENT + SKIP + STOP	Adjustment 1 has two two-way normally open (***) pneumatic valves: one in parallel (SKIP), the other in series (STOP) (pict. 8)
5	TWO SPEEDS	The control has one adjustment 1 (V1 speed) and in parallel one adjustment + STOP (V2 speed) 1st speed = V1+V2 - 2nd speed = V1

EXAMPLE OF ORDER

Brake under tension with SKIP 100 stroke
 Nameplate: F3-02-100
 Code : 417302-02

*** : On request normally closed valves

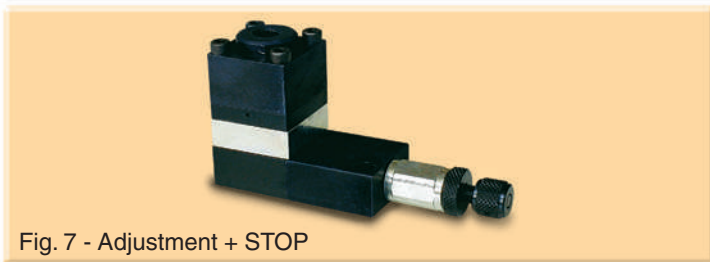
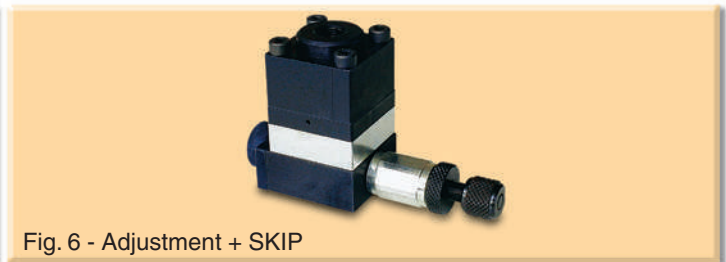



HYDRAULIC CONTROL UNDER TENSION

on rod outlet



Fig. 9 - F3-01- HYDRAULIC CONTROL

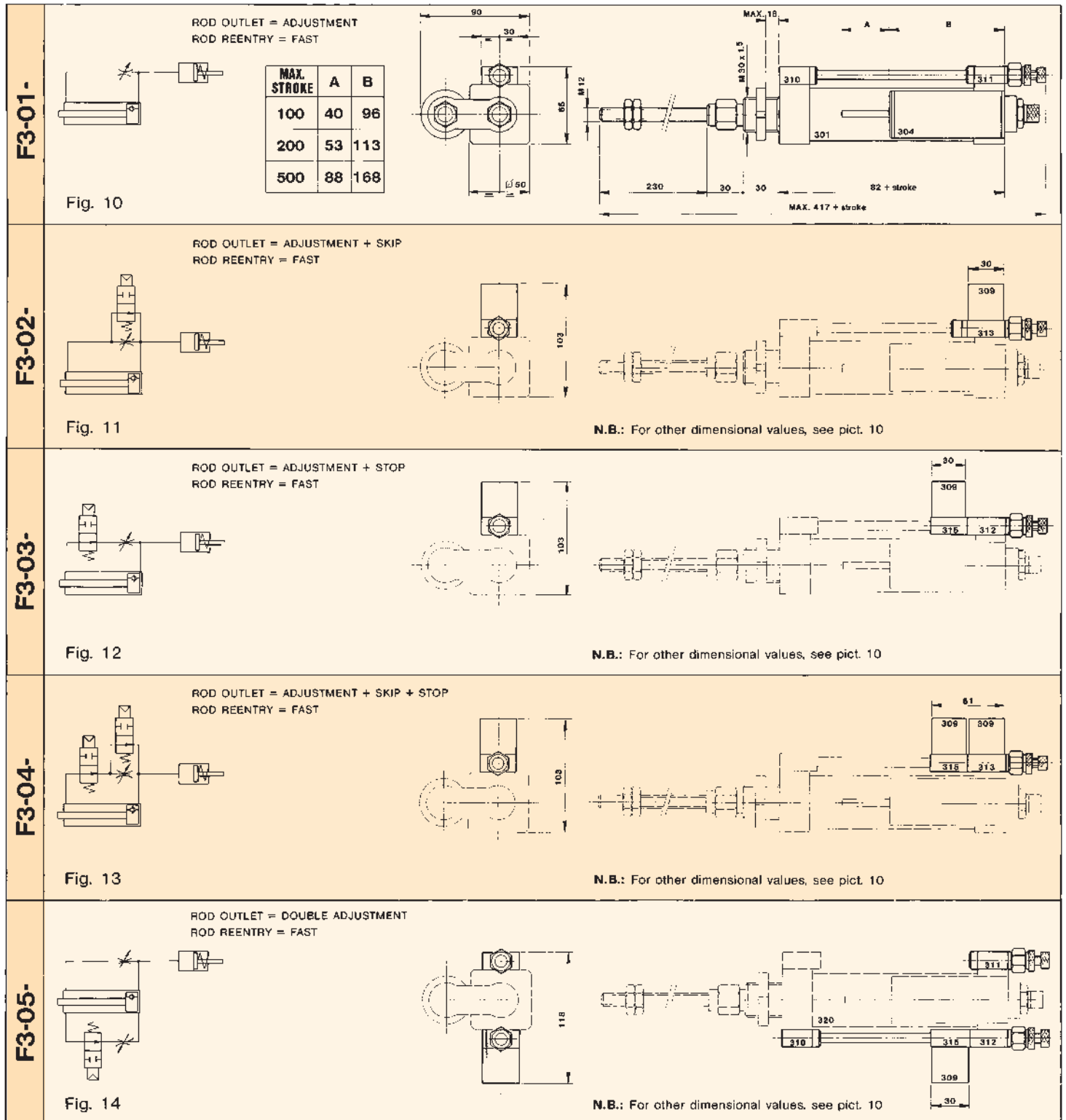



HYDRAULIC CONTROL ON THRUST

on rod reentry



Fig. 15 - F3-11- HYDRAULIC CONTROL

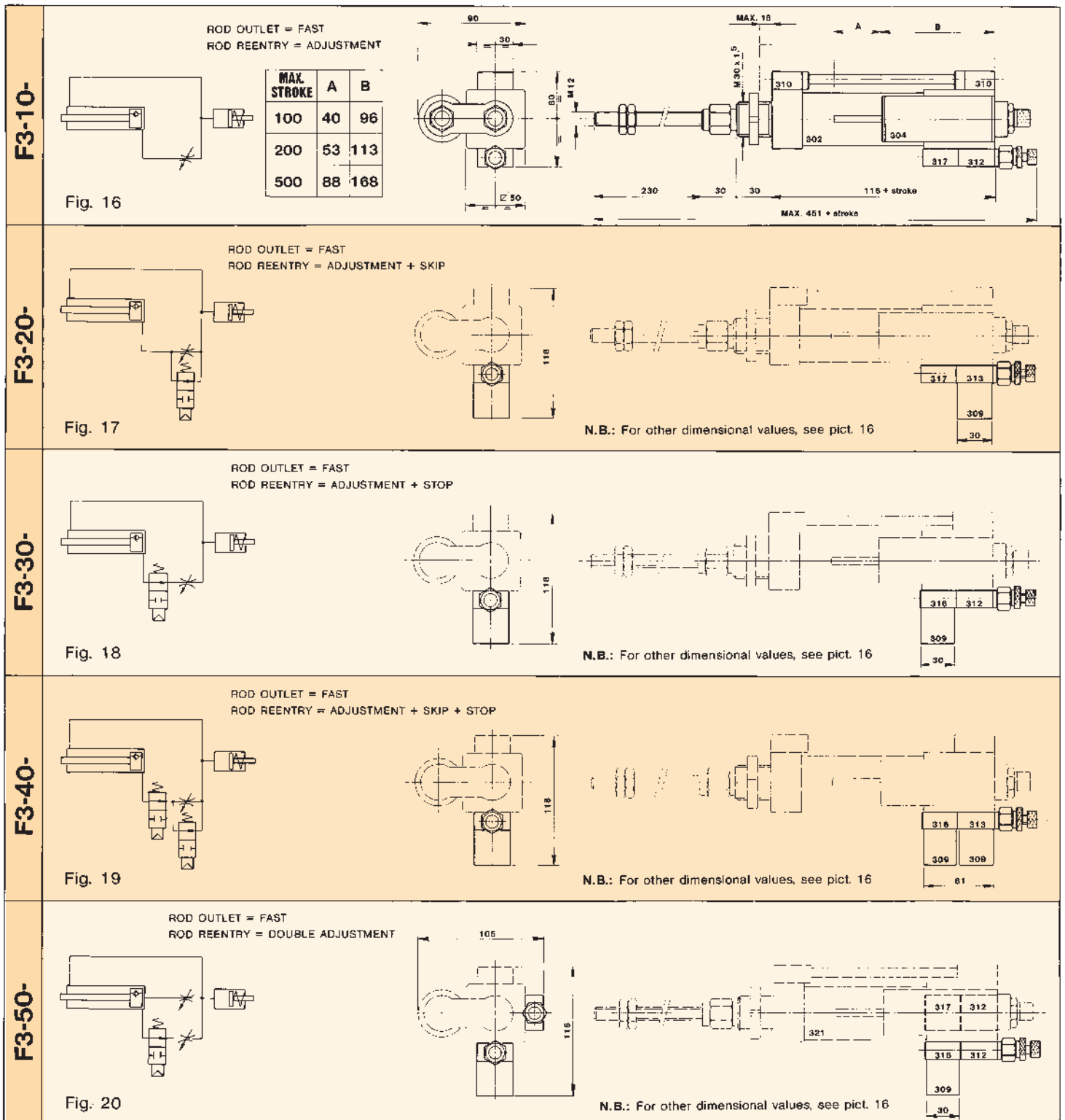



D.A.F. HYDRAULIC CONTROL

double braking action



Fig. 21 - F3-11- HYDRAULIC CONTROL

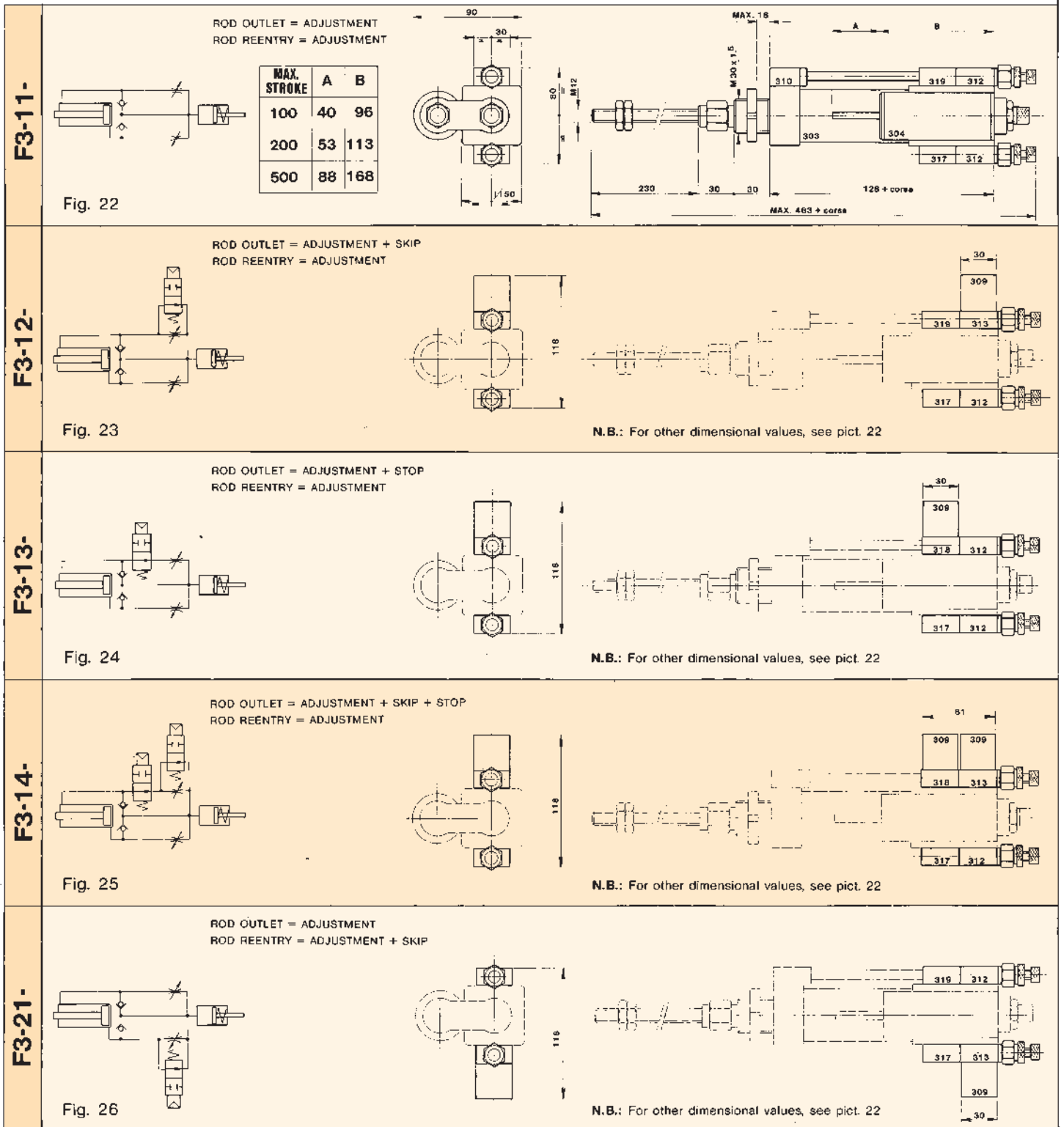



D.A.F. HYDRAULIC CONTROL

double braking action

<p>F3-22-</p>	<p>ROD OUTLET = ADJUSTMENT + SKIP ROD REENTRY = ADJUSTMENT + SKIP</p> <p>Fig. 27</p>	<p>N.B.: For other dimensional values, see pict. 22</p>
<p>F3-23-</p>	<p>ROD OUTLET = ADJUSTMENT + STOP ROD REENTRY = ADJUSTMENT + SKIP</p> <p>Fig. 28</p>	<p>N.B.: For other dimensional values, see pict. 22</p>
<p>F3-24-</p>	<p>ROD OUTLET = ADJUSTMENT + SKIP + STOP ROD REENTRY = ADJUSTMENT + SKIP</p> <p>Fig. 29</p>	<p>N.B.: For other dimensional values, see pict. 22</p>
<p>F3-31-</p>	<p>ROD OUTLET = ADJUSTMENT ROD REENTRY = ADJUSTMENT + STOP</p> <p>Fig. 30</p>	<p>N.B.: For other dimensional values, see pict. 22</p>
<p>F3-32-</p>	<p>ROD OUTLET = ADJUSTMENT + SKIP ROD REENTRY = ADJUSTMENT + STOP</p> <p>Fig. 31</p>	<p>N.B.: For other dimensional values, see pict. 22</p>
<p>F3-33-</p>	<p>ROD OUTLET = ADJUSTMENT + STOP ROD REENTRY = ADJUSTMENT + STOP</p> <p>Fig. 32</p>	<p>N.B.: For other dimensional values, see pict. 22</p>



D.A.F. HYDRAULIC CONTROL

double braking action

F3-34-	<p>ROD OUTLET = ADJUSTMENT + SKIP + STOP ROD REENTRY = ADJUSTMENT + STOP</p> <p>Fig. 33</p>	<p>N.B.: For other dimensional values, see pict. 22</p>
F3-41-	<p>ROD OUTLET = ADJUSTMENT ROD REENTRY = ADJUSTMENT + SKIP + STOP</p> <p>Fig. 34</p>	<p>N.B.: For other dimensional values, see pict. 22</p>
F3-42-	<p>ROD OUTLET = ADJUSTMENT + SKIP ROD REENTRY = ADJUSTMENT + SKIP + STOP</p> <p>Fig. 35</p>	<p>N.B.: For other dimensional values, see pict. 22</p>
F3-43-	<p>ROD OUTLET = ADJUSTMENT + STOP ROD REENTRY = ADJUSTMENT + SKIP + STOP</p> <p>Fig. 36</p>	<p>N.B.: For other dimensional values, see pict. 22</p>
F3-44-	<p>ROD OUTLET = ADJUSTMENT + SKIP + STOP ROD REENTRY = ADJUSTMENT + SKIP + STOP</p> <p>Fig. 37</p>	<p>N.B.: For other dimensional values, see pict. 22</p>

SPARE PARTS SECTION

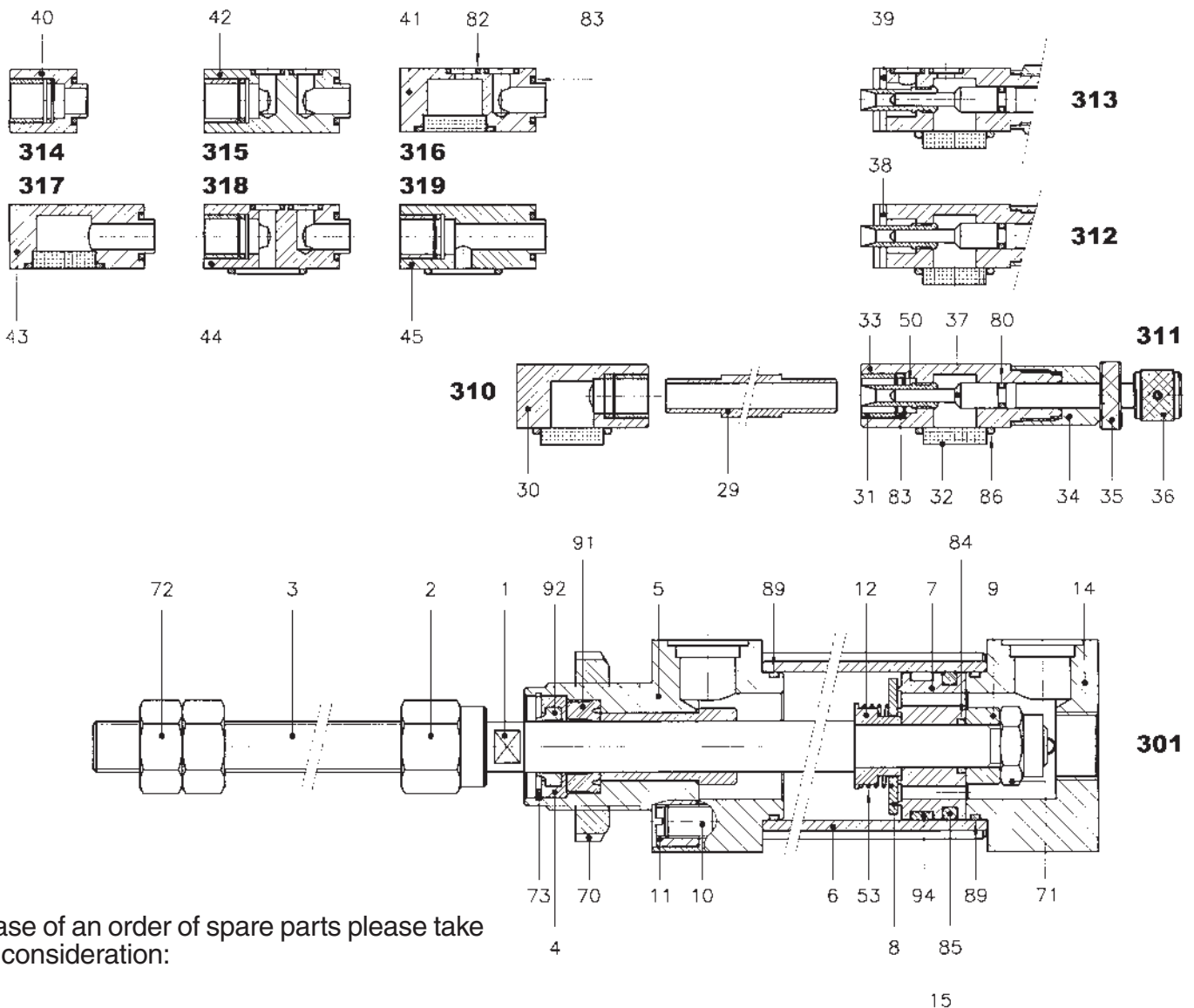

In case of an order of spare parts please take into consideration:

- indicate the position number of the part and the nameplate of the hydraulic control;
- On request and always indicating the complete nameplate of the hydraulic control a complete series of gaskets can be supplied;
- The position written in small characters refer to single details, the ones written in big characters refer to groupes.

SPARE PARTS SECTION

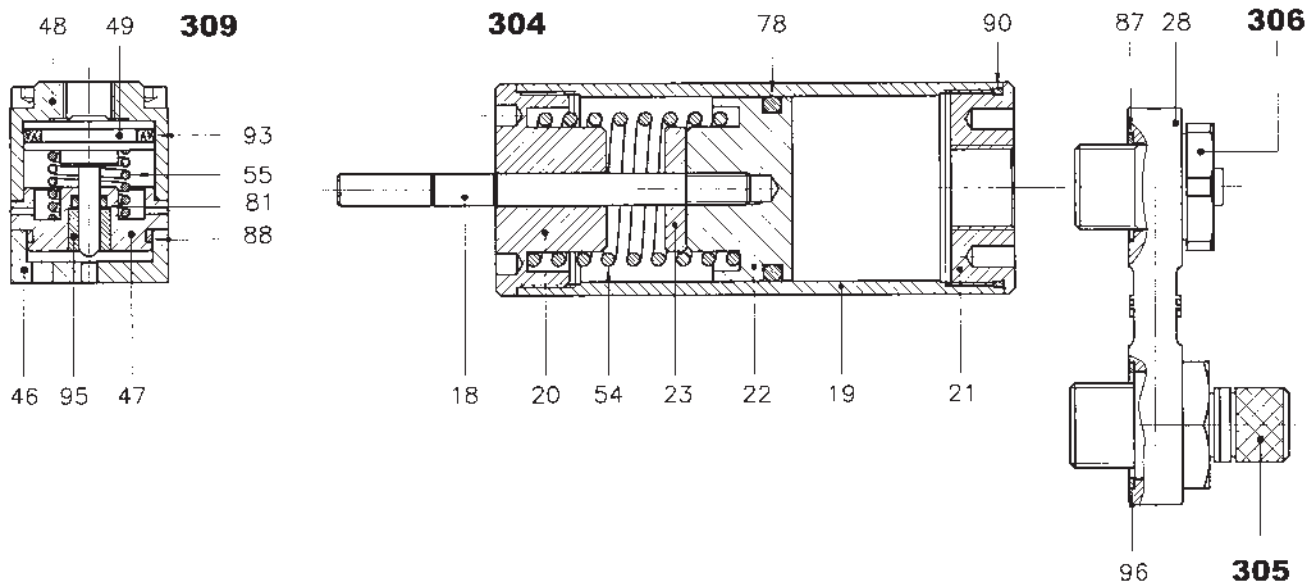

COMPONENTS HYDRAULIC CONTROL F3

POS	CODE	NAME
1	1.17.301	Rod
2	1.17.310	Nut for rod
3	1.17.309	Threaded rod
4	1.17.317	Cup
5	2.17.301	Front flange with bush
6	1.17.302	Cylinder liner
7	1.17.313	Piston
8	1.17.314	Washer
9	1.17.312	Spacer
10	1.17.303	Tie rod
11	1.17.311	Nut for the tie rod
12	1.17.315	Valve spacer
13	1.17.316	D.A.F. spacer
14	1.17.320	Rear flange under TENSION
15	1.17.321	Rear flange THRUST
16	1.17.322	D.A.F. Rear flange
17	1.17.323	Piston guide
18		Rod tank
19		Tank liner
20	1.17.352	Spring guide
21	1.17.351	Cover
22	1.17.353	Tank piston
23	1.17.354	Tank spacer
28	1.17.355	Connecting flange
29	1.17.304	Connecting pipe
30	1.17.330	Flange - pipe bloc
31	1.17.325	Bush
32	1.17.324	Lubricant filter
33	1.17.331	Adjusting bloc under TENSION
34	1.17.327	Threaded bush
35	1.17.328	Ring nut

POS	CODE	NAME
36	1.17.329	Knob
37	1.17.395	Adjusting screw
38	1.17.332	Adjusting bloc with clutch
39	1.17.333	Adjusting bloc with clutch and SKIP
40	1.17.334	Term. bloc for the adjust. and SKIP
41	1.17.336	Stop bloc for THRUST and D.A.F.
42	1.17.335	Stop bloc for under TENSIONS
43	1.17.337	Con. bloc for THRUST and D.A.F.
44	1.17.338	STOP bloc for D.A.F.
45	1.17.339	Connecting bloc for D.A.F.
46	1.17.340	Lower servo controlled flange
47	1.17.341	Intermediate servo controlled flange
48	1.17.342	Pneumatic servo controlled body
49	2.17.303	S.G. piston
50	1.17.396	Bushing
51	1.17.410	Piston
53	1.M015	Spring
54		Tank spring
55	1.M063	Spring
56	1.M058	Spring
60	1.09.300	942 piston
70	6KM6 M30X1,5	KM6 M 30x1,5 ring nut
71	6B980 M10	DIN 980 M10 aut. lower nut
72	6A5588 M12	UNI 5588 M12 nut
73	6A3654 D24	UNI 3654 Ø24 stop ring
78	6OR 136	OR 136 gasket
80	6OR 101	OR 101 gasket
81	6OR 102	OR 102 gasket
82	6OR 103	OR 103 gasket
83	6OR 107	OR 107 gasket
84	6OR 110	OR 110 gasket

POS	CODE	NAME
85	6OR 136	OR 136 gasket
86	6OR 2062	OR 2062 gasket
87	690206	Washer
88	6OR 2081	OR 2081 gasket
89	6OR 2125	OR 2125 gasket
90	6OR 2131	OR 2131 gasket
91	6NI300/12.22.8	NI 300/12.22.8 gasket
92	6WRM 047070	WRM 047070 gasket
93	6PK 25	PK 25 gasket
94	1.17.361	Guiding ring
95	690151	Bush
96	690224	Washer
301	3.17.301	G.R. Cylinder under TENSION
302	3.17.302	G.R. Cylinder THRUST
303	3.17.303	G.R. D.A.F. Cylinder
304	3.17.304	G.R. Tank
305	3.17.305	Lubricant priming valve
306	3.17.306	Exhaust valve
309	3.17.309	Two-way valve - pneumatic control
310	3.17.310	Bloc 310
311	3.17.311	Adjustment 311
312	3.17.312	Adjustment 312
313	3.17.313	Adjustment 313
314	3.17.314	Bloc 314
315	3.17.315	Bloc 315
316	3.17.316	Bloc 316
317	3.17.317	Bloc 317
318	3.17.318	Bloc 318
319	3.17.319	Bloc 319

AUTHORIZED RETAILER



G.P.A. ITALIANA s.r.l. - Via L. da Vinci, 25 - 22074 Lomazzo (CO) - ITALY
 Tel. +39 02 96779406 - Fax +39 02 96370473
 E-mail: gpa@gpa-automation.com - www.gpa-automation.com