

1953年ROSSI MOTORIDUTTORI成立于意大利Modena，至今已发展成为世界著名的生产标准减速机及减速电机的制造商之一。

公司自始至终致力于产品质量的提高，保持持续投资和最新解决方案系统的研究。

ROSSI MOTORIDUTTORI是意大利第一家，欧洲第二家获得 ISO 9001-2000质量体系认证的传动机械制造商。

现在，ROSSI 公司可以提供的产品范围很广，其中包括：平行轴，直角轴，同轴减速机及减速电机，蜗轮蜗杆及行星系列。这些产品通过不断地改进其性能及适应性而日新月异。

近年来，公司不断引入新产品，如低啮合齿隙伺服减速电机，整体式变频电机等，以便能在动力传输领域内保持技术和市场的领先优势。

ROSSI 公司的产品一直以极高的质量和可靠性闻名于各种重工业应用领域。

经过在工业领域中50多年的发展，ROSSI 同时为许多特殊的应用领域提供了特殊的产品和设计，如：单螺杆挤出机，化学搅拌机，冷却塔，辊道，沥青搅拌机，混凝土搅拌机，风力发电机，自动化设备及工业机器人等。

在过去20年中，ROSSI 公司业绩增长迅速。其也归功于我们的众多海外分支机构，如德国，西班牙，英国，法国，丹麦，荷兰，澳大利亚，印度，美国和中国等子公司，以及全世界经销商的销售网络。

A04系列蜗杆减速机及减速电机是ROSSI公司的一系列全新升级产品。这个系列包括10个标准规格和4个加强型规格，额定输出扭矩可达19,000Nm，传动比从10-16,000(可以提供组合减速机)。减速电机的功订范围 从0.09kw-55kw,电机为IEC标准电机。

A04系列的主要特点是：

- 多样安装箱体结构，同时适用于地脚安装和法兰安装。
- 单一模块铸铁箱体
- 经渗碳硬化和表面硬化的圆柱蜗杆，材料为合成钢16CrNi4或20MnCr5 UNI 7846-78(根据规格不同选用)，渐开线(ZI)齿形经研磨。
- 经过滚刀整形的蜗杆与蜗轮精确共轭，蜗轮轮毂由球墨铸铁或灰口铸铁(根据规格不同)制成，轮缘由镍青铜CuSn12Ni-B (EN1982-98)制成，且经过磷化。
- 从规格100开始配有标准冷却风扇。

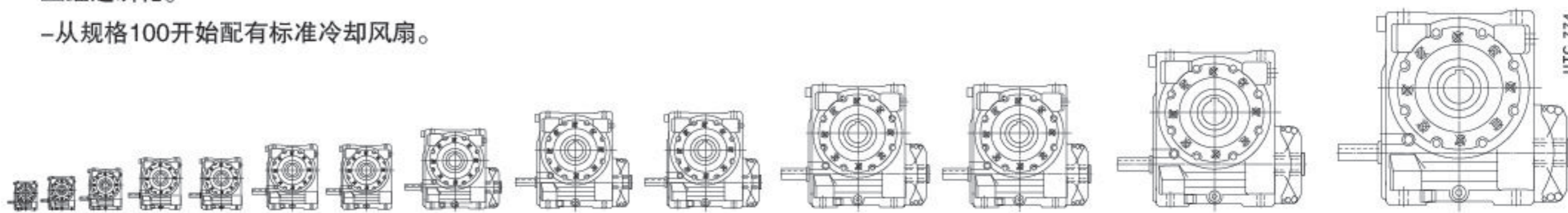

32	40	50	63	64	80	81	100	125	126	160	161	200	250	1)
71	82	100	125		150	180		225		280		335	410	H
48	56	67	80		100	125		150		180		225	280	H ₀
19	24	28	32		38	40		48		70	75	90	110	D
4	7.1	12.8	21.8	26.1	42.2	50		83	133	158		245	291	T _{N2}
7.5	14	25	47.5		80	90		160	300	500	560	1000	1900	T ₂
180	250	355	530		800	1250		1800 (2000)	2650	3000		4500	6300 (7100)	F ₂

1) H, H₀ 中心高; D: ∅ 输出轴直径; T_{N2} 额定扭矩[daNm]; F₂ 输出轴端径向载荷[daNm]. 1) H, H₀ shaft height; D: ∅ low speed shaft end[mm]; T_{N2}, T_{2max} torque[daNm]; F₂ radial load[daN].
(注: 1 daN=10N)

Since 1953 ROSSI MOTORIDUTTORI S.p.A with the headquarter in Modena (Italy) has been the manufacturer of a standard range of gear reducers and gear motors .

Since its origins the Company has always been committed to product quality, the importance of continuous investment and systematic research into new solutions as its prime objectives.

As a matter of fact, ROSSI MOTORIDUTTORI has been the first transmissions manufacturer in Italy and second in Europe to obtain the Quality System Certification according to ISO 9001 in 1992, and in 2003 the Vision 2000 Certification too.

Nowadays ROSSI can offer a wide range of products including parallel, right angle and coaxial shaft gear reducers and gear motors, worm and planetary ones. These products are constantly updated to improve their performance and flexibility.

In the recent years the Company has introduced on the market new products such as servo gear motors with reduced and low backlash, and electric motors with integrated inverter, in order to keep at the leading edge of technical and market developments in the power transmission field. ROSSI MOTORIDUTTORI products has conceived for granting highest reliability in the heaviest application conditions.

During more than 50 years of experience in industrial applications, Rossi Motoriduttori has been also developing products specifically designed for sectors, as for example: single screw extruder, chemical agitator, cooling tower, roller ways, asphalt mixer, cement mixer, wind mill generator, automation and robotics.

A considerably development of ROSSI market has been achieved during the last twenty years also thanks to the opening of foreign subsidiaries in Germany, Spain, UK, France, Denmark, Holland, Australia, India, USA and China and thanks to a network of specialised distributors worldwide.

A04 is the fully upgraded series of worm gear reducers and gearmotors of ROSSI MOTORIDUTTORI. The series include 10 sizes and 4 strengthened size pairs with nominal torque ≤ 19000 Nm and ratio transmission value from 10 up to 16000 (possible with combined units). The gearmotors range is from 0.09kw up to 55kw with motor standardized to IEC.

The main characteristic of A04 products are:

- Universal casing for feet or flange mounting
- Monolithic and cast iron casing
- Casehardened and hardened cylindrical worm in 16 CrNi4 or 20 MnCr5 UNI 7846-78 steel (depending on size) with ground and superfinished involute profile (ZI)
- Wormwheel with profile especially conjugate to the worm through hob optimization, with hub in spheroidal or grey cast iron (depending on size) and Ni bronze CuSn 12Ni2-B (EN 1982-98) gear rim with high pureness and controlled phosphor contents;
- Cooling fan standard from size 100

2- 产品说明

- 1) 多样安装：箱体带有一体的地脚和B14法兰。
- 2) 单一模块铸铁箱体，刚性和精度均极高。200 UNI ISO 185 铸铁整体式、带有加强筋，润滑油容量大。
- 3) 减速箱内的空间充裕，可以容纳更多润滑油，从而提高蜗轮、蜗杆和轴承的使用寿命
- 4) 使用IEC标准电机。
- 5) 齿轮副的设计先进，运动规律性好、噪音低、效率高、稳定性好，工作寿命长，可靠性高，强度和承受过载的能力高。可承受最重的应用状况。
- 6) 使用合成润滑油的油浴式润滑，可以保证整个寿命期的润滑：供机时已经注满油并提供1个（规格32...64）或2个（规格80、81）带阀注油销；规格为100...250的减速机，供机时不带有润滑油。
- 7) 性能高且可靠：每件产品均已通过性能测试。（蜗杆为ZI渐开线齿形，与蜗轮齿形配合精确）。
- 8) 带有键槽的空心低速轴，规格63-250带有卡簧槽。材料为球墨铸铁（规格32，40为灰口铸铁，规格200和250为钢制），与蜗轮成一体；可以提供标准实心轴（左伸或右伸）或标准双伸实心轴。
- 9) 风扇冷却（规格100...250）：结构上预留了双向伸出的蜗杆轴，需要使用时拆除风扇罩通风网盖即可。
- 10) 蜗杆上轴承：双列角接触球轴承加球轴承（规格32）：面对面锥滚子轴承（规格40...161）；成对的背对背锥滚子轴承加一个球轴承（规格200，250）。
- 11) 蜗轮上轴承：球轴承（规格32...160）；锥滚子轴承（规格161...250）。
- 12) 经渗碳硬化和表面硬化的圆柱蜗杆、材料为合成钢16CrNi4或20MnCr5 UNI 7846-78（根据规格不同选用），渐开线（ZI）齿形经研磨。
- 13) 经过滚刀整形的蜗杆与蜗轮精确共轭，蜗轮轮毂由球墨铸铁或灰口铸铁（根据规格不同）制成，轮缘由镍青铜CuSn12Ni-B（EN1982-98）制成，且经过磷化。
- 14) 齿轮副承载能力校核根据断裂和磨损进行，热功率通过校核。
- 15) 油漆：外部涂层为环氧粉末油漆（规格32...81）或合成油漆（规格100...250），可以适应通常的工业环境，适于在其外面直接加涂其他的合成油漆；颜色为蓝色RAL 5010 DIN 1843；内部涂层为环氧粉末油漆（规格32-81）或环氧树脂油漆（规格100-250），耐合成润滑油腐蚀。
- 16) 根据BS721-83标准进行承载能力校核，达到ISO/CD 14521标准。
- 17) 另外，可选电机的范围也非常广：三相异步电动机-标准电机、直流制动电机或直流安全制动电机（规格63-132）；双速电机-标准电机或制动电机；频繁启制动直线双速制动电机：2.4,2.6,2.8,2.12极电机（带有直流制动器）；防爆电机；双轴（头、尾）电机；直流电机；非标准电压和非标准频率电机；还可以提供保护过载和过热的附加装置；新系列的同步（无刷）或异步电机。

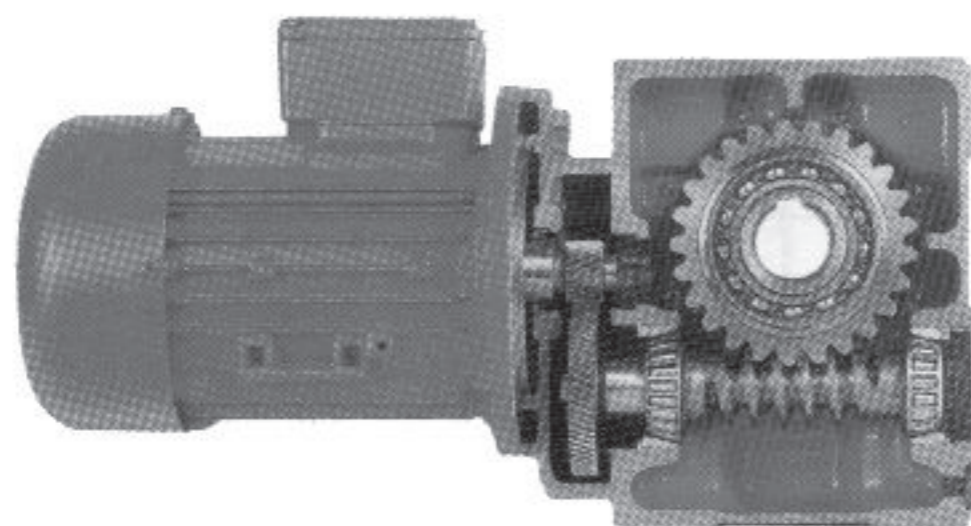

32 ... 81

2- Specifications

- 1) Universal mounting having feet integral with casing and B14 flange
- 2) Rigid and precise cast iron monolithic casing 200 UNI ISO 185 cast iron monolithic casing with transverse stiffening ribs, and high oil capacity;
- 3) Generous internal space between train of gears and casing allowing: high oil capacity and greater duration of worm wheel and worm bearings;
- 4) IEC standardized motor
- 5) High efficiency, running precision, regular motion and noiselessness, constant performances, life and reliability, strength and overload withstanding and suitability for heaviest applications
- 6) Oil bath lubrication with synthetic oil for 《long-life》 lubrication: units provided with one plug (sizes 32...64) or two plugs (sizes 80 and 81) supplied filled with oil; with filler plug with valve, drain plug and level plug (sizes 100...250) supplied without oil; sealed;
- 7) High, reliable and tested performances (ZI worm involute profile and adequately conjugate worm wheel profile)
- 8) Hollow low speed shaft with keyway, and (sizes 63-250) ... with circlip groove for removal purposes: in spheroidal cast iron (grey cast iron for sizes 32 and 40) integral with worm wheel (sizes 32...161) or steel (sizes 200 and 250); standard (left or right extension) or double extension low speed shaft.
- 9) Fan cooling (sizes 100...250); use of double extension worm-shaft simply obtained by removing the fan cowl centre disc; for
- 10) Bearings on worm: double row angular contact ball bearing plus ball bearing (size 32); face-to-face taper roller bearings (sizes 40...161); paired back-to-back taper roller bearings plus one ball bearing (sizes 200 and 250);
- 11) Bearing on wormwheel: ball bearings (sizes 32...160); taper roller bearings (sizes 161...250);
- 12) Casehardened and hardened cylindrical worm in 16 CrNi4 or 20 MnCr5 UNI 7846-78 steel (depending on size) with ground and superfinished involute profile (ZI);
- 13) Wormwheel with profile especially conjugate to the worm through hob optimization, with hub in spheroidal or grey cast iron (depending on size) and **Ni bronze** CuSn 12Ni2-B (EN 1982-98) gear rim with high pureness and controlled phosphor contents;
- 14) Train of gear load capacity calculated for breakage and wear thermal capacity verified.
- 15) Paint: external coating in epoxy powder paint (sizes 32...81) or in synthetic paint (sizes 100...250) appropriate for resistance to normal industrial environments and suitable for the application of further coats of synthetic paint; colour blue RAL 5010 DIN 1843; internal protection in epoxy powder paint (sizes 32...81) or in epoxy resin paint (sizes 100...250) appropriate for resistance to synthetic oils;
- 16) Worm gear pair load capacity and efficiency to BS 721-83 integrated with ISO/CD 14521.
- 17) Besides a wide motor range is available : asynchronous 3 phase motor, standard or brake motor with d.c. brake or with d.c. safety brake (size 63-132); two-speed , standard or brake motor; two-speed brake motor for traverse movements: 2.4, 2.6, 2.8, 2.12 poles (always with d.c. brake); explosion-proof; with second shaft end; d.c. motor; non-standard voltage and frequency; protection devices against overloads and overheating. New series of synchronous (brushless) and asynchronous servomotors.

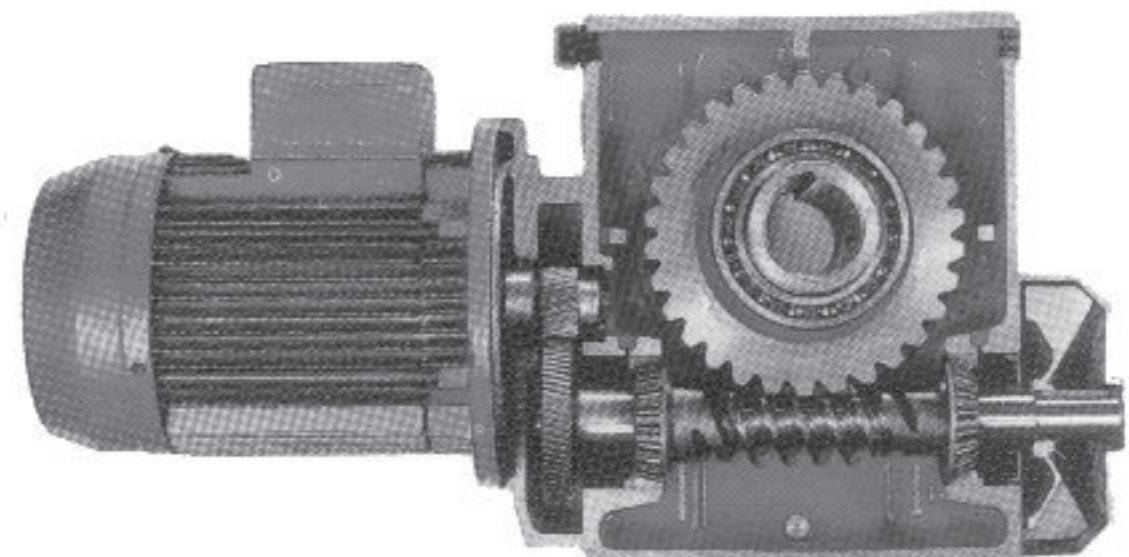

100 ... 250