

# MODEL 1465

## PRESSURE REDUCING REGULATOR

### SECTION I

#### I. DESCRIPTION AND SCOPE

The Model 1465 is a high pressure reducing regulator designed primarily for analytical sampling and low flow applications. Size is 1/4" (DN8). With proper trim utilization, the unit is suitable for liquid and gaseous service. Refer to Technical Bulletin 1465-TB for design conditions and selection recommendations. **NOT FOR DEAD END SERVICE.**

### SECTION II

#### II. INSTALLATION

**⚠ CAUTION**

Do not dead end (no flow demand) downstream of the regulator. The inlet pressure will transmit past the metal seat (not positive shut-off) and equalize on the downstream. This will lead to diaphragm failure, regulator malfunction, and possible damage to system instrumentation downstream.

**⚠ CAUTION**

For welded installations, all internal trim parts, seals and diaphragm(s) must be removed from regulator body prior to welding into pipeline. The heat of fusion welding will damage non-metallic parts if not removed. *NOTE: This does not apply to units equipped with extended pipe nipples.*

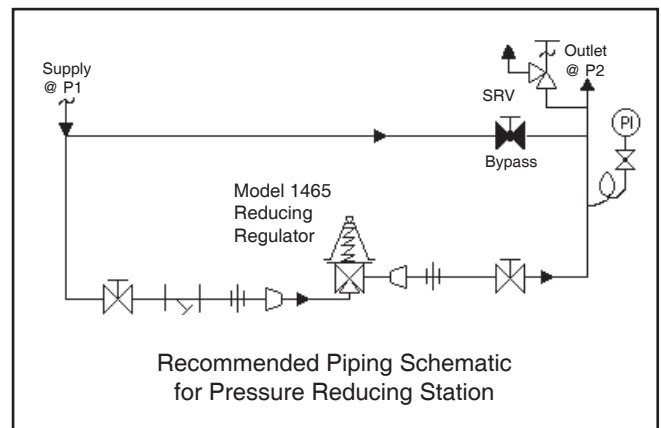

**⚠ CAUTION**

Installation of adequate overpressure protection is recommended to protect the regulator and all downstream equipment from damage in the event of regulator failure.

1. An inlet block valve should always be installed.
2. If service application is continuous such that shutdown is not readily accomplished, it is recommended that an inlet block valve, outlet block valve, and a manual bypass valve be installed.
3. Pipe unions should be installed to allow removal from piping.
4. An outlet pressure gauge should be located approximately ten pipe diameters downstream, and within sight.
5. All installations should include a downstream relief device if the inlet pressure could exceed the pressure rating of any downstream equipment or the maximum outlet pressure rating of the unit.
6. Clean the piping of all foreign material including chips, welding scale, oil, grease and dirt before installing the regulator. Strainers are recommended.
7. In placing thread sealant on pipe ends prior to engagement, ensure that excess material is removed and not allowed to enter the regulator upon startup.
8. Flow Direction: Install in accordance with the flow direction arrow cast on the body. The inlet pressure is connected to the bottom connection and the outlet (reduced) pressure is connected to the side connection. When installing, hold by the body (1) hex to keep the regulator firm.

9. Basic Regulator - (Refer to Figure 1): Regulator may be installed in any position in relation to the pipe. Recommended position is with spring chamber vertical upwards. Orient such that the spring chamber vent hole does not collect rainwater or debris.
10. Regulators are not to be direct buried underground.
11. For insulated piping systems, recommendation is to not insulate the regulator.

 **CAUTION**

**DO NOT HYDROSTATIC TEST THROUGH AN INSTALLED UNIT; ISOLATE REGULATOR FROM TEST. The upper range spring pressure level listed on the nameplate is the recommended "upper operative limit" for the sensing diaphragm (see Section IV. Startup, Number 7). Higher pressures could cause internal damage. In addition, note on the nameplate that the Inlet and Outlet pressure and temperature ratings are at different levels.**

## SECTION III

### III. PRINCIPLE OF OPERATION

1. Movement occurs when the inlet pressure passes by the seat causing a distributive force on the underside of the diaphragm. This, in turn, opposes the point force of the range spring causing upward movement of the diaphragm, allowing

the plug to seat. When set pressure decreases, due to demand, the distributive force beneath the diaphragm lessens - allowing the range spring to open the seat and regulate pressure.

2. A complete diaphragm failure will cause the regulator to fail open.

## SECTION IV

### IV. START-UP

1. Start with the block valves closed. A bypass valve may be used to maintain outlet pressure in the downstream system without changing the following steps.
2. Relax the range spring (10) by turning the adjusting screw (12) counter clockwise (CCW) a minimum of three (3) full revolutions. This reduces the outlet (downstream) pressure setpoint. **NOTE:** *If the Option -2 or -22 is utilized, the adjusting screw (12) and locknut (13) are replaced with a knob (18) and locknut (13). With Option -2 +80 or -22 +80, the adjusting screw (12) and locknut (13) are replaced with a handwheel subassembly (20) and locknut (13).*
3. If it is a "hot" piping system, and equipped with a bypass valve, slowly open the bypass valve to preheat the system piping and to allow slow expansion of the piping. Ensure proper steam trap operation if installed. Closely monitor outlet (downstream) pressure via gauge to ensure not over-pressurizing. **NOTE:** *If no bypass valve is installed, extra caution should be used in starting up a cold system; i.e. do everything slowly.*
4. Crack open the outlet (downstream) block valve.
5. Slowly open inlet (upstream) block valve observing the outlet (downstream) pressure gauge. Determine if the regulator is flowing. If not, slowly

rotate the regulator adjusting screw (12) clockwise (CW) until flow begins.

6. Continue to slowly open the inlet (upstream) block valve until fully open.
7. Continue to slowly open the outlet (downstream) block valve, especially when the downstream piping system isn't pressurized. If the outlet (downstream) pressure exceeds the desired pressure, close the block valve and go to Step 2, then return to Step 4.
8. When flow is established steady enough that the outlet (downstream) block valve is fully open, begin to slowly close the bypass valve if installed.
9. Develop system flow to a level near its expected normal rate, and reset the regulator setpoint by turning the adjusting screw (12) CW to increase outlet pressure or CCW to reduce outlet pressure.
10. Reduce system flow to a minimum level - observe setpoint. Outlet pressure will rise from the setpoint of Step 9. The maximum rise in outlet pressure on decreasing flow should not exceed the stated upper limit of the range spring (10) by greater than 10%; i.e. 5-30 psig (.34-2.1 Barg) range spring, at low flow the outlet pressure should not exceed 33 psig (2.3 Barg). If it does, consult factory.

## SECTION V

### V. SHUTDOWN

1. On systems with a bypass valve, and where system pressure is to be maintained as the regulator is shut down, slowly open the bypass valve while closing the inlet (upstream) block valve. Fully close the inlet (upstream) block valve. (When on bypass, the system pressure must be constantly observed and manually regulated. ) Close the outlet (downstream) block valve.



### CAUTION

**Do not leave a bypassed regulator unattended.**

2. If the regulator and system are to both be shutdown, slowly close the inlet (upstream) block valve. Close the outlet (downstream) valve only if regulator removal is required.

## SECTION VI

### VI. MAINTENANCE



### WARNING

**SYSTEM UNDER PRESSURE. Prior to performing any maintenance, isolate the regulator from the system and relieve all pressure. Failure to do so could result in personal injury.**

#### A. General:

1. Maintenance procedures hereinafter are based upon removal of the regulator from the pipeline where installed.
2. Owner should refer to owner's procedures for removal, handling, cleaning and disposal of non-reusable parts, i.e. O-rings, etc.
3. Refer to Figure 1 for the standard regulator and its options.

#### B. Diaphragm Replacement:

1. Securely install the body (1) in a vise with the spring chamber (2) directed upwards.



### WARNING

**SPRING UNDER COMPRESSION. Prior to removing spring chamber, relieve spring compression by backing out the adjusting screw or handwheel. Failure to do so may result in flying parts that could cause personal injury.**

2. Relax range spring (10) by turning adjusting screw (12) CCW until removed from spring chamber (2). **NOTE:** If the Option -2 or -22 is utilized, the adjusting screw (12) and locknut (13) are replaced with a knob (18) and locknut (13). With the Option -2 +80 or -22 + 80, the adjusting screw (12) and locknut (13) are replaced with a handwheel subassembly (20) and locknut (13).
3. Loosen spring chamber (2) by placing wrench on "flats" and rotating CCW. **DO NOT** use the flats on either side of the vent hole.

4. Remove spring chamber (2), spring button (11), and range spring (10). **NOTE:** For units with Option -80 (spring ranges 270-400 psig (18.6-27.6 Barg) and 360-500 psig (24.8 -34.5 Barg)) also remove the thrust bearing (15), upper bearing washer (16), and lower bearing washer (17). Inspect threads of spring chamber (2) for cleanliness.
5. Remove pressure plate (9) and inspect to ensure no deformation due to over-pressurization. If deformed, replace.
6. Remove diaphragm(s) (8), O-ring (7) and pusher plate (6). Inspect pusher plate (6) to ensure no deformation due to over-pressurization. If deformed, replace. Discard O-ring (7) and diaphragm(s) (8).
7. Clean body (1) and body recess according to owner's procedures. **NOTE:** On regulators originally supplied as "oxygen clean", Option 1465-55, maintenance must include a level of cleanliness equal to Cashco's cleaning Standard #S-1134. Contact factory for details.
8. Install new O-ring (7) and diaphragm(s) (8). **NOTE:** Refer to the quantity of diaphragm(s) (8) incorporated in the bill of materials listing. Depending on outlet pressure level, multiple metal diaphragms may be "stacked".
9. Visually center pressure plate (9) on diaphragm(s) (8). Place the range spring (10) on to the retainer hub of the pressure plate (9).
10. Place multi-purpose, high temperature grease into the depression of the spring button (11) where adjusting screw (12) bears. Set spring button (11) onto range spring (10); ensure spring button (11) is laying flat. **NOTE:** For units with Option -80 (spring ranges 270-400 psig (18.6-27.6 Barg) and 360-500 psig (24.8 -34.5 Barg) position spring button (11), thrust

bearing (15), upper bearing washer (16), and lower bearing washer (17) on top of the range spring (10).

11. Apply an appropriate lubricant to the threads of the spring chamber (2). Reverse Steps B.2 and B.3 to complete assembly. Tighten spring chamber (2) to body (1) with a **30-35 Ft-lbs torque value**.
12. Pressurize with air and spray with liquid leak detector to test around body (1) and spring chamber (2) for leakage. Ensure that an outlet pressure is maintained during this leak test of at least mid-range spring level; i.e. 125-200 psig (8.6-13.8 Barg) range spring, 163 psig (11.2 Barg) test pressure minimum.

**C. Trim Inspection:**

1. Trim inspection requires that the diaphragm(s) be removed. Refer to previous procedure Section VI.B, steps 1 through 7.
2. Remove body (1) from vise and secure a screwdriver, tool end up, in vise. Set body (1) so as to engage screwdriver into slotted end of the plug (3) from the body (1) inlet connection and hold firm.
3. Remove pusher plate (6). Looking down into the body (1) cavity, use a slotted tool to push down on the spring seat (5) and slip sideways to disengage (through slot) from plug (3).
4. Remove spring seat (5) and plug spring (4).
5. Grasp plug (3) while carefully lifting body (1). Remove plug (3) from body (1) inlet, taking care not to allow plug (3) to drop out.
6. Inspect integral seat in body (1). If seat shows erosion or wear, replace regulator.

7. Clean debris from within body (1) cavity. Clean parts to be reused according to owner's procedures. **NOTE:** *On regulators originally supplied as "oxygen clean", Option 1465-55 maintenance must include a level of cleanliness equal to Cashco's cleaning spec. #S-1134. Contact factory for details.*
8. Inspect spring seat (5), plug spring (4) and plug (3). If worn, nicked or depressed, replace regulator.
9. Lap plug (3) with lapping compound by inserting it back up into the body (1) inlet and hold firm. Engage a screwdriver into the slotted end of the plug (3) from the body (1) inlet and rotate plug (1) back and forth in a circular motion. Do not overlap. Clean lapping compound on plug (3) and in body (1).
10. Reverse steps 1 through 5 for reassembly. **NOTE:** *When reassembling plug (3), plug spring (4), and spring seat (5), be sure that this "assembly" is centered into the body (1) cavity to ensure proper seating of plug (3). Apply an appropriate lubricant to the threads of the spring chamber (2). Tighten spring chamber (2) to body (1) with a 30-35 Ft-lbs torque value.*
11. Bench test unit for suitable operation. **NOTE:** *Regulators are not tight shut off devices. Even if pressure builds up beyond setpoint, a regulator may or may not develop bubble tight shut off.*
12. Pressurize with air and spray with liquid leak detector to test around body (1) and spring chamber (2) for leakage. Ensure that an outlet pressure is maintained during this leak test of at least mid-range spring level; i.e. 125-200 psig (8.6-13.8 Barg) range spring, 163 psig (11.2 Barg) test pressure minimum.

**SECTION VII**

**VII. TROUBLE SHOOTING GUIDE**

1. Erratic operation; chattering.

Possible Causes	Remedies
A. Oversized regulator; inadequate rangeability.	A1. Check actual flow conditions, re-size regulator for minimum and maximum flow. A2. Increase flow rate. A3. Decrease regulator pressure drop; decrease inlet pressure by placing a throttling orifice in inlet piping union. A4. Install next step higher range spring. Contact factory. A5. Before replacing regulator, contact factory.
B. Cavitation	B. Use multiple 1465's in series to stage the pressure drops. Refer to 1465 Technical Bulletin for water cavitation chart.

2. Leakage through the spring chamber vent hole.

Possible Causes	Remedies
A. Normal-life diaphragm failure.	A. Replace diaphragm
B. Abnormal short-life diaphragm failure.	B1. Can be caused by excessive chattering. See No. 1 to remedy chatter.
	B2. Can be caused by corrosive action. Consider alternate diaphragm material.
	B3. For composition diaphragms, ensure not subjecting to over-temperature conditions.
	B4. Downstream (outlet) pressure buildup occurring that overstresses diaphragms. Relocate regulator or protect with safety relief valve.

3. Regulator can't pass sufficient flow.

Possible Causes	Remedies
A. Regulator undersized.	A1. Confirm by opening bypass valve together with regulator. A2. Check actual flow conditions, re-size regulator; if regulator has inadequate capacity, replace with larger unit.
B. Plugged trim.	B. Remove regulator from line and check for debris in inlet connection.
C. Incorrect range spring(screwing in CW of adjusting screw does not allow bringing pressure level up to proper level).	C. Replace range spring with proper higher range. Contact factory.
D. Too much droop	D1. Review droop expected. D2. Contact factory.
E. Cavitation	E. Use multiple 1465's in series to stage the pressure drops. Refer to 1465 Technical Bulletin for water cavitation chart.

4. Excessive pressure downstream.

Possible Causes	Remedies
A. Regulator not closing tightly.	A. Inspect the seating. Check the plug (3), plug spring (4), and spring seat (5) are centered in body (1) cavity. Replace regulator should these steps not remedy.
B. Downstream block.	B. Check system; isolate (block) flow at regulator inlet - not outlet. Relocate regulator if necessary.
C. No pressure relief protection.	C. Install safety relief valve or rupture disc.
D. Restricted diaphragm movement.	D. Ensure no moisture in spring chamber at temperatures below freeze point. Ensure no dust or debris entering vent opening. If rainwater or debris enter, re-orient regulator.

5. Sluggish operation.

Possible Causes	Remedies
A. Fluid too viscous.	A. Heat fluid. Contact factory

6. Excessive seat leakage.

Possible Causes	Remedies
A. Foreign matter on seating surface, erosion of seating surface.	A. Inspect and clean seat. If seat eroded, replace regulator.
B. Cavitation	B. Use multiple 1465's in series to stage pressure drops. Refer to 1465 Technical Bulletin for water cavitation chart.

7. Leakage out of threaded connection between body and spring chamber.

Possible Causes	Remedies
A. Insufficient spring chamber torque.	A. Tighten spring chamber on body using sufficient torque.
B. Damaged o-ring	B. Replace o-ring.

## SECTION VIII

### VIII. ORDERING INFORMATION NEW REPLACEMENT UNIT vs PARTS "KIT" FOR FIELD REPAIR

To obtain a quotation or place an order, please retrieve the Serial Number and Product Code that was stamped on the metal name plate and attached to the unit. This information can also be found on the Bill of Material ("BOM"), a parts list that was provided when unit was originally shipped. (Serial Number typically 6 digits). Product Code typical format as follows: (last digit is alpha character that reflects revision level for the product).

□□□□ - □□□□ 7 - □□□□□□□□□□

#### **NEW REPLACEMENT UNIT:**

Contact your local Cashco, Inc., Sales Representative with the Serial Number and Product code. With this information they can provide a quotation for a new unit including a complete description, price and availability.



#### **CAUTION**

**Do not attempt to alter the original construction of any unit without assistance and approval from the factory. All purposed changes will require a new name plate with appropriate ratings and new product code to accommodate the recommended part(s) changes.**

#### **PARTS "KIT" for FIELD REPAIR:**

Contact your local Cashco, Inc., Sales Representative with the Serial Number and Product code. Identify the parts and the quantity required to repair the unit from the "BOM" sheet that was provided when unit was originally shipped.

**NOTE:** *Those part numbers that have a quantity indicated under "Spare Parts" in column "A" reflect minimum parts required for inspection and rebuild, - "Soft Goods Kit". Those in column "B" include minimum trim replacement parts needed plus those "Soft Goods" parts from column "A".*

If the "BOM" is not available, refer to the cross-sectional drawings included in this manual for part identification and selection.

A Local Sales Representative will provide quotation for appropriate Kit Number, Price and Availability.

The contents of this publication are presented for informational purposes only, and while every effort has been made to ensure their accuracy, they are not to be construed as warranties or guarantees, express or implied, regarding the products or services described herein or their use or applicability. We reserve the right to modify or improve the designs or specifications of such product at any time without notice. Cashco, Inc. does not assume responsibility for the selection, use or maintenance of any product. Responsibility for proper selection, use and maintenance of any Cashco, Inc. product remains solely with the purchaser.

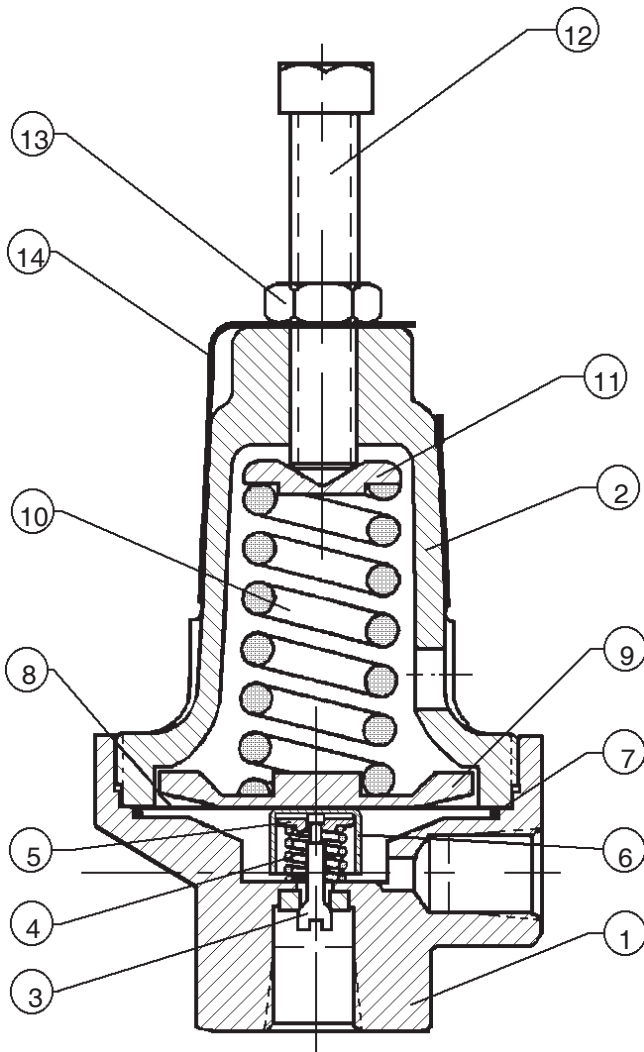
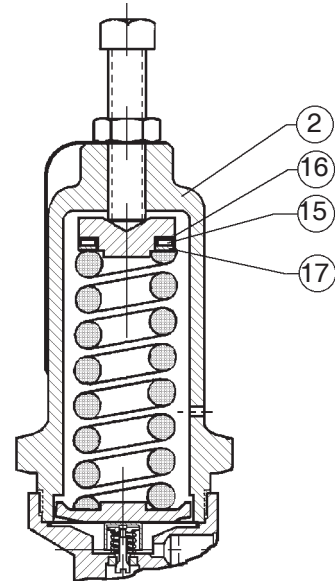
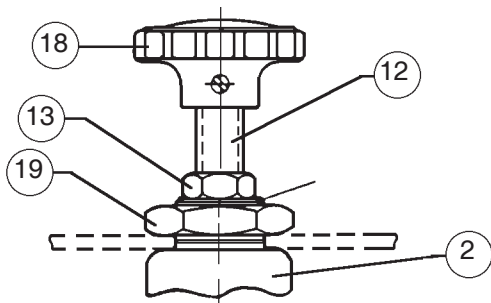

Figure 1: Basic Model 1465



Option -80, High Pressure Spring Chamber Construction



Option -22 Panel Mounting (hand-wheel portion is same for Option -2 Handwheel)

Item Number	Description
1	Body Subassembly
2	Spring Chamber
3	Plug
4	Spring
5	Spring Seat
6	Pusher Plate
7	O-ring
8	Diaphragm
9	Pressure Plate
10	Range Spring
11	Spring Button
12	Adjusting Screw
13	Adjusting Screw Lock Nut
14	Name Plate
15	Thrust Bearing
16	Upper Bearing Washer
17	Lower Bearing Washer
18	Knob
19	Mounting Nut

ITEM NUMBERS NOT SHOWN

20	Handwheel Subassembly
21	Pin

## ATEX 2014/34/EU: Explosive Atmospheres and Cashco Inc. Products



Cashco, Inc. declares that the products listed in the table below has been found to comply with the Essential Health and Safety Requirements relating to the design and construction of products intended for use in potentially explosive atmospheres given in Annex II of the ATEX Directive 2014/34/EU. Compliance with the Essential Health and Safety Requirements has been assured by compliance with EN ISO 80079-36:2016 and EN ISO 80079-37:2016. The product will be marked as follows:

CE Ex II 2 G  
Ex h IIB T6... T1 Gb  
1000ATEXR1 X

The 'X' placed after the technical file number indicates that the product is subject to specific conditions of use as follows:

1. The maximum surface temperature depends entirely on the operating conditions and not the equipment itself. The combination of the maximum ambient and the maximum process medium temperature shall be used to determine the maximum surface temperature and corresponding temperature classification, considering the safety margins described prescribed in EN ISO 80079-36:2016, Clause 8.2. Additionally, the system designer and users must take precautions to prevent rapid system pressurization which may raise the surface temperature of system components and tubing due to adiabatic compression of the system gas. Furthermore, the Joule-Thomson effect may cause process gases to rise in temperature as they expand going through a regulator. This could raise the external surface temperature of the regulator body and the downstream piping creating a potential source of ignition. Whether the Joule-Thomson effect leads to heating or cooling of the process gas depends on the process gas and the inlet and outlet pressures. The system designer is responsible for determining whether the process gas temperature may raise under any operating conditions.
2. Where the process medium is a liquid or semi-solid material with a surface resistance in excess of  $1G\Omega$ , special precautions shall be taken to ensure the process does not generate electrostatic discharge.
3. Special consideration shall be made regarding the filtration of the process medium if there is a potential for the process medium to contain solid particles. Where particles are present, the process flow shall be  $<1\text{m/s}$  ( $<3.3\text{ft/s}$ ) in order to prevent friction between the process medium and internal surfaces.
4. Effective earthing (grounding) of the product shall be ensured during installation.
5. The valve body/housing shall be regularly cleaned to prevent build up of dust deposits.
6. Regulators must be ordered with the non-relieving option (instead of the self-relieving option) if the process gas they are to be used with is hazardous (flammable, toxic, etc.). The self-relieving option vents process gas through the regulator cap directly into the atmosphere while the non-relieving option does not. Using regulators with the self-relieving option in a flammable gas system could create an explosive atmosphere in the vicinity of the regulator.
7. Tied diaphragm regulators with outlet ranges greater than 7 barg (100 psig) should be preset to minimize the risk that improper operation might lead to an outboard leak and a potentially explosive atmosphere.
8. All equipment must only be fitted with manufacturer's original spare parts.
9. Ensure that only non-sparking tools are used, as per EN 1127-1, Annex A.



	<b>PRODUCT</b>
<b>REGULATORS</b>	31-B, 31-N
	1164, 1164(OPT-45)
	1171, 1171(OPT-45), 1171(CRYO)
	2171, 2171(OPT-45), 2171(CRYO), 3171
	1465, 3381, 3381(OPT-45), 3381(OPT-40)
	4381, 4381(OPT-37), 4381(CRYO), 4381(OPT-45), 5381
	MPRV-H, MPRV-L
	PBE, PBE-L, PBE-H
	CA-1, CA-2
	CA1, SA1, CA4, SA4, CA5, SA5
	DA2, DA4, DA5, DA6, DA8
	DA0, DA1, DAP, SAP
	SLR-1, SLR-2, PTR-1
	ALR-1, ULR-1, PGR-1
	BQ, BQ(OPT-45), BQ(CRYO)
	123, 123(CRYO), 123(OPT-45), 123(OPT-46G)
	123-1+6, 123-1+6(OPT-45), 123-1+6(OPT-46G), 123-1+6+S, 123-1+6+S(OPT-40)
	1000HP, 1000HP(OPT-37), 1000HP(OPT-45), 1000HP(OPT-45G), 1000HP(CRYO)
	1000HP-1+6, 1000HP-1+8, 1000LP, 1000LP(OPT-45), 1000LP(OPT-46G)
	6987
	8310HP, 8310HP-1+6, 8310HP-1+8, 8310LP, 8311HP, 8311LP
	345, 345(OPT-45)
	BA1/BL1, PA1/PL1
	C-BPV, C-PRV, C-CS
	D, D(CRYO), D(OPT-37), D(OPT-20), D(OPT-45)
	DL, DL(LCC), DL(OPT-45)
	BR, BR(CRYO)
	HP, HP(LCC), HP(OPT-45), HP(OPT46G), HP-1+6+S(OPT-40), HP-1+6+S
	P1, P2, P3, P4, P5, P7
	B2, B7
	POSR-1, POSR-2
	5200P, 5300P
	135
NW-PL, NW-SO	
CG-PILOT	
FG1	
<b>CONTROL VALVES</b>	RANGER, 987, PREMIER
	964, 521, 988, 988-MB, 989
	2296/2296HF
	SCV-30, SCV-S
	FL800/FL200
<b>TANK BLANKETING</b>	8700, 8910, 8920, 8930, 8940
	2100, 2199
	3100, 3200, 3300, 3400, 3500, 3600, 3700
	1078, 1088, 1100, 1049
	5100, 5200, 5400, 5500
	4100, 4200, 4300, 4400, 4500, 4600
<b>MISC</b>	764P/PD, 764-37, 764T

Cashco, Inc.  
P.O. Box 6  
Ellsworth, KS 67439-0006  
PH (785) 472-4461  
Fax. # (785) 472-3539  
www.cashco.com  
email: sales@cashco.com  
Printed in U.S.A. IOM-1465

Cashco GmbH  
Handwerkerstrasse 15  
15366 Hoppegarten, Germany  
PH +49 3342 30968 0  
Fax. No. +49 3342 30968 29  
www.cashco.com  
email: germany@cashco.com

Cashco do Brasil, Ltda.  
Al.Venus, 340  
Indaiatuba - Sao Paulo, Brazil  
PH +55 11 99677 7177  
Fax. No.  
www.cashco.com  
email: brazil@cashco.com