

Mueller 2300 Series Resilient Wedge Gate Valves

Mueller Resilient Wedge Gate Valves have features to make them easier to operate, preserve sealing capability, and interior coating integrity for many years of reliable service. In addition to popular end connection options, Mueller brand RW valves can be ordered with Mueller's exclusive AquaGrip® System that incorporates an o-ring sealed compression connection and integral pipe restraint in one "ready to use" easy and quick to install package.

Mueller 2"-12" 2300 Series Resilient Wedge Gate Valve Features



6" shown

- **350 PSIG (2400 kPa/24 barg) Maximum Working Pressure** – Hydrostatically tested at 700 psig (4800 kPa/48 barg).
- **Dual-Purpose Lifting Lugs** – new dual-purpose lifting lugs provide stability for the valve box. Accommodates strap or hooks; provides valve box alignment, eliminating need for valve box adapter.+
- **American Made Quality** – factory in Chattanooga, TN with ISO 9001 certification. Certified to ANSI/NSF 61 & 372. Manufactured and tested in compliance with ANSI/AWWA Standard C515 or C509. UL 262 Listed and FM 1120/1130 Approved.
- **Ductile Iron Construction** - Valve body, bonnet, disc, stuffing box, & op nut.
- **T-Head Bolt Retention** – improved T-head bolt retention feature eliminates need for anti-rotation bolts.
- **Triple O-ring Seals** – two above thrust collar and one below, retain lubricant in this critical area. Top two are replaceable with valve fully open and under pressure. Fourth O-ring serves as dirt seal.
- **Two-Anti-Friction Washers With Lubrication** – made of polymer, one above and one below the thrust collar, reduce operating torque to open or close valve.
- **Stem** – forged manganese bronze bar stock is upset, then machined to form a thrust collar for superior strength in this critical area.
- **Guide Cap Bearings** – made of polymer and snapped over rubber covered wedge guides, provide bearing surfaces that protect both wedge and interior body coating from wear and aid in easy operation – even the largest valves installed horizontally. Rollers, tracks and scrapers are not needed.
- **Smooth, Oversized Water Way** – full, round, unobstructed flow way accommodates full size cutters, provides superior flow characteristics and reduces pumping costs.**
- **Mueller Pro-Guard® Fusion Bonded Epoxy Coating** – 10 mils* thick protects all inside and outside iron surfaces, and complies with AWWA C550.
- **316 Stainless Steel Fasteners**
- **Integral Legs** – stands upright for easier handling and storage.
- **10-Year Limited Warranty** – assured reliability (see separate Mueller Warranty document for terms).
- **Designed For Potable Water Applications**

*Nominal

**16" valve requires 1/2" undersized cutter, 54" valve requires 48" cutter

Mueller 14" – 54" 2361 Series Resilient Wedge Gate Valve Features

In addition to all the features of the smaller 2361 series valves, large size Mueller 2361 series RW valves offer these features:



- **Stem** – 18"-54" manganese bronze casting with integral thrust collar.

SIZE	AWWA C515 WORKING PRESSURE	UL WORKING PRESSURE	FM WORKING PRESSURE
14"-16"	250	250	250
18"-24"	250	175 x	250
30"-54"	250	NA	NA

x UL Listed without gearing

INTRODUCING MUELLER RESILIENT WEDGE GATE VALVE AND SUPER CENTURION® FIRE HYDRANT WITH HYMAX GRIP® RESTRAINT

The HYMAX Grip® restraint is offered on 4"-12" A-2361 Mueller Resilient Wedge Gate Valves and Super Centurion® 250 Fire Hydrants. The HYMAX Grip restraint is a versatile single-bolt restraint capable of joining a wide selection of pipe types and diameters, resulting in easier, more flexible installations.



Easy Installation

- No assembly required
- Stab-fit design
- Easy-to-access top-facing bolt
- Pressure-assist gasket and restraint technology

Flexibility

- Joins and restrains pipes of different types and diameters
- Works with Ductile Iron, Cast Iron, PVC, and HDPE
- Dynamic deflection up to 4 degrees per grip joint end

Configurations

A-2361 Resilient Wedge Gate Valve

- Sizes 4" - 12"
- Hymax Grip x Hymax Grip and Hymax Grip x Flange
- AWWA C515 Rated to 250 PSIG
- Certified to ANSI/NSF 61 and 372

Super Centurion 250 Fire Hydrant

- Size 5-1/4" - Elbow shoe
- Size 4-1/2" - Elbow shoe
- ANSI/AWWA C502 Rated to 250 PSIG
- Certified to ANSI/NSF 61 and 372

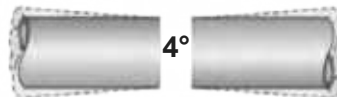



www.muellercompany.com • moreinfo@muellercompany.com

Rev. 4-20

- Catalog number
 - A-2361-20** Mechanical joint ends (with accessories unassembled)
 - A-2361-23** Mechanical joint ends (less accessories)
 - A-2361-25** Mechanical joint ends (with transition gaskets accessories unassembled)
- Sizes – 3", 4", 6", 8", 10", 12"
- Non-rising stem (NRS)
- Meets or exceeds all applicable requirements of ANSI/AWWA C515*** Standard, UL 262 Listed, FM 1120/1130 Approved, and certified to ANSI/NSF 61 & 372
- Standard mechanical joint ends comply with ANSI/AWWA C111
- Nominal 10 mils Mueller Pro-Gard® Fusion Bonded Epoxy coated interior and exterior surfaces Epoxy coating meets or exceeds all applicable requirements of ANSI/AWWA C550 Standard
- Iron wedge, symmetrical and fully encapsulated with molded rubber; no exposed iron
- Triple O-ring seal (2 above the thrust collar and 1 below)
- 2" square wrench nut - open left or open right
- 350 psig (2400 kPa/24 barg) maximum working pressure; 700 psig (4800 kPa/48 barg) static test pressure
- UL Listed, FM Approved: 350 psig (2400 kPa/24 barg)
- Designed for potable water applications



A-2361-20 shown

Options

See page 10.54 for more information on Resilient Wedge Gate Valve options

- Position indicators
- Low zinc, silicon bronze ASTM B98-C66100/H02 stem
- Stainless steel stem: Type 304, Type 316
- Handwheel
- EPDM Disc and o-rings

Resilient wedge gate valve parts

Catalog Part Number	Description	Material	Material Standard
G-16	Bonnet Bolts & Nuts	316 Stainless Steel	ASTM F593 (bolt) ASTM F594 (nut)
G-41	Stuffing Box Bolts & Nuts	316 Stainless Steel	ASTM F593 (bolt) ASTM F594 (nut)
G-49	Stem O-rings (3)	Nitrile	ASTM D2000
G-200	Wrench Nut Cap Screw	316 Stainless Steel	ASTM F593
G-201	Stuffing Box O-ring	Nitrile	ASTM D2000
G-202	Wrench Nut	Ductile Iron	ASTM A536 ▼
G-203	Stem	Bronze	ASTM B138
G-204	Hand Wheel (not shown)	Cast Iron +	ASTM A126 CL.B
G-205	Stem Nut	Bronze	ASTM B584
G-206	Guide Cap Bearings	Acetal	-
G-207	Stuffing Box with dirt seal	Ductile Iron Nitrile	ASTM A536 ▼ ASTM D2000
G-208	Anti-friction Washers (2)	Acetal	-
G-209	Wedge, Rubber Encapsulation	Ductile Iron* SBR	ASTM A536 ▼ ASTM D2000
G-210	Bonnet	Ductile Iron	ASTM A536 ▼
G-211	Bonnet O-ring +++	Nitrile	ASTM D2000
G-212	Body	Ductile Iron	ASTM A536 ▼

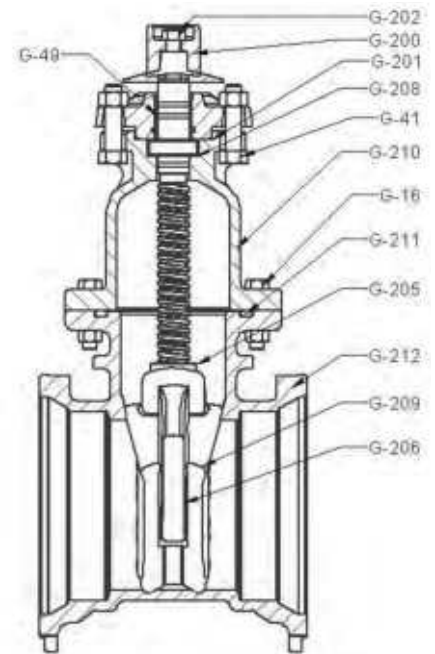

+++ 3" valves use a bonnet gasket

*Fully encapsulated in molded rubber with no iron exposed;

▼ Material strength ASTM A536 65-45 minimum

+ Manufacturer's option to change material to ductile iron ASTM A536

*** 3" valves meet or exceed all applicable requirements of ANSI/AWWA C509 Standard

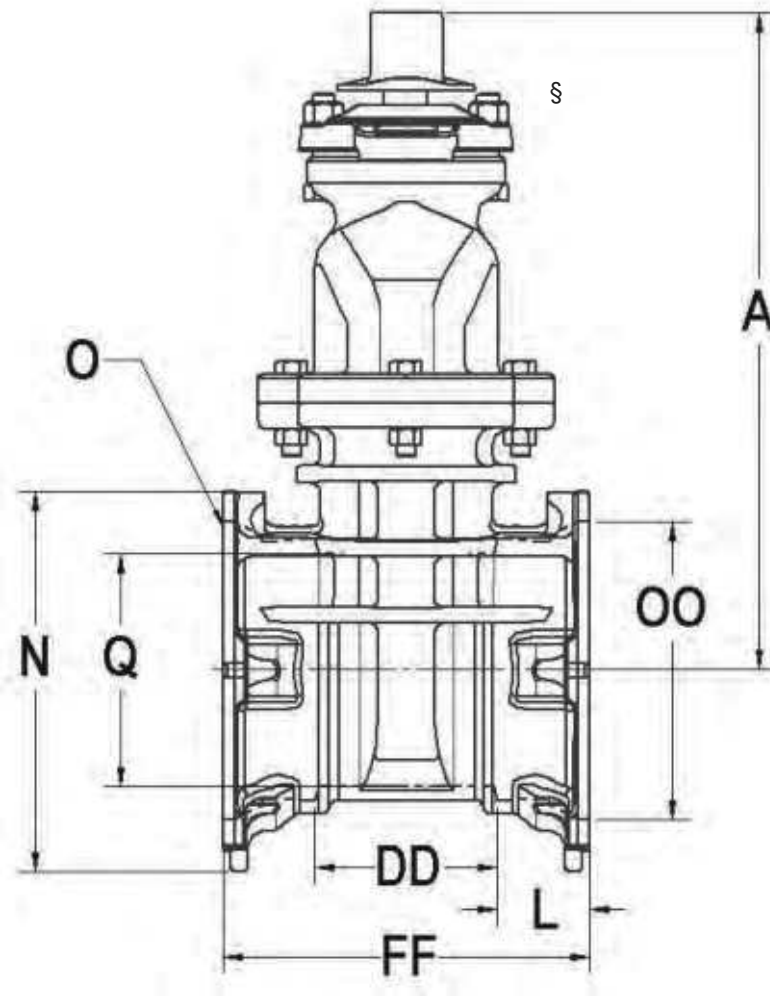

Dimensions

Dimension	Nominal Size					
	3"	4"	6"	8"	10"	12"
A	12.38	14.19	18.00	21.50	25.50	28.62
FF	9.62	9.50	10.00	10.50	11.50	12.00
L	2.50	2.50	2.50	2.50	2.50	2.50
N	7.50	8.40	10.41	12.68	15.24	18.024
O (number and size of holes)	4--.88	4--.88	6--.88	6--.88	8--.88	8--.88
DD	4.62	4.50	5.00	5.50	6.50	7.00
Q	3.30	4.30	6.30	8.30	10.30	12.30
OO (bolt circle diameter)	6.19	7.50	9.50	11.75	14.00	16.25
Turns to open	11	14	20.5	26.5	33.0	38.5
Weight*	83	70	112	162	238	303
Closing Torque (FT-LBS), Non-Geared	52	75	110	150	185	225
Closing Torque (FT-LBS), Bevel	31	44	65	88	109	132
Closing Torque (FT-LBS), Spur	N/A	41	60	82	101	123

*All dimensions are in inches. All weights include accessories are in pounds and are approximate.

Rev. 7-19

- Catalog number
A-2361-6 flanged ends
- Sizes – 3", 4", 6", 8", 10", 12"
- Meets or exceeds all applicable requirements of ANSI/AWWA C515*** Standard, UL 262 Listed, FM 1120/1130 Approved, and certified to ANSI/NSF 61 & 372
- Flanged end drilling complies with ASME/ANSI B16.1 Class 125**
- Iron body with nominal 10 mils Mueller Pro-Guard® Fusion Bonded Epoxy Coated interior and exterior surfaces
- Epoxy coating meets or exceeds all applicable requirements of ANSI/AWWA C550 Standard
- Iron wedge, symmetrical and fully encapsulated with molded rubber; no exposed iron
- Non-rising stem (NRS)
- Triple O-ring seal (2 above the thrust collar and 1 below)
- 350 psig (2400 kPa/24 barg) maximum working pressure; 700 psig (4800 kPa/48 barg) static test pressure
- UL Listed, FM Approved: 350 psig (2400 kPa/24 barg)
- Designed for potable water applications



A-2361-6 shown

† Approved for backflow prevention devices by USC (for 4" - 10" sizes)

Options

See page 10.54 for more information on Resilient Wedge Gate Valve options

- Position indicators
- Stainless steel stem: Type 304, Type 316
- Low zinc, silicon bronze ASTM B98-C66100/H02 stem
- 2" square wrench nut
- P/N 10/16 Drilling
- EPDM Disc and O-rings

Resilient wedge gate valve parts

Catalog Part Number	Description	Material	Material Standard
G-16	Bonnet Bolts & Nuts	316 Stainless Steel	ASTM F593 (bolt) ASTM F594 (nut)
G-41	Stuffing Box Bolts & Nuts	316 Stainless Steel	ASTM F593 (bolt) ASTM F594 (nut)
G-49	Stem O-rings (3)	Nitrile	ASTM D2000
G-200	Wrench Nut Cap Screw	316 Stainless Steel	ASTM F593
G-201	Stuffing Box O-ring	Nitrile	ASTM D2000
G-202	Wrench Nut	Ductile Iron	ASTM A536 ▼
G-203	Stem	Bronze	ASTM B138
G-204	Hand Wheel	Cast Iron +	ASTM A126 CL.B
G-205	Stem Nut	Bronze	ASTM B584
G-206	Guide Cap Bearings	Acetal	-
G-207	Stuffing Box with dirt seal	Ductile Iron Nitrile	ASTM A536 ▼ ASTM D2000
G-208	Anti-friction Washers (2)	Acetal	-
G-209	Wedge, Rubber Encapsulation	Ductile Iron* SBR	ASTM A536 ▼ ASTM D2000
G-210	Bonnet	Ductile Iron	ASTM A536 ▼
G-211	Bonnet O-ring +++	Nitrile	ASTM D2000
G-212	Body	Ductile Iron	ASTM A536 ▼

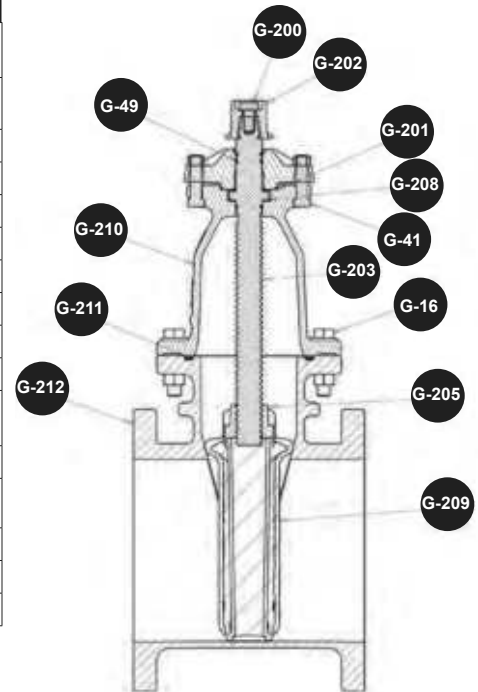

+++ 3" valves use a bonnet gasket

*Fully encapsulated in molded rubber with no iron exposed;

▼ Material strength ASTM A536 65-45 minimum

** Per ANSI/AWWA C111 working pressure above 250psi requires the use of a special gasket rated for higher pressure.

+ Manufacturer's option to change material to ductile iron ASTM A536

*** 3" valves meet or exceed all applicable requirements of ANSI/AWWA C509 Standard

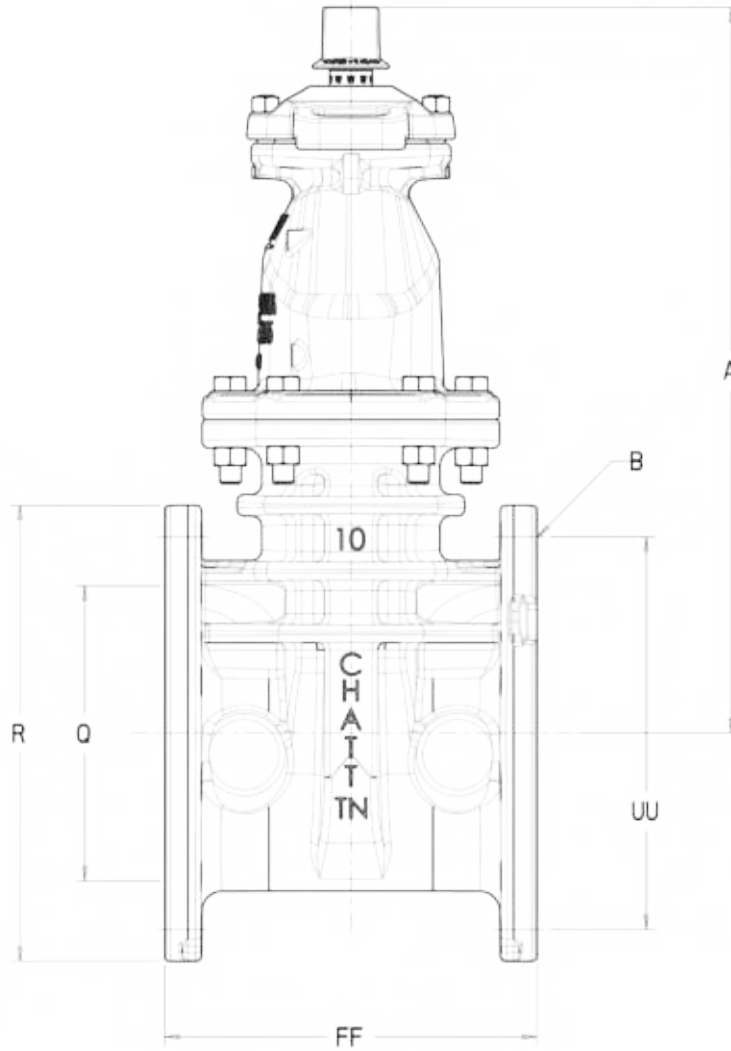

Dimensions

Dimension	Nominal Size					
	3"	4"	6"	8"	10"	12"
A	12.38	14.19	18.00	21.50	25.50	28.62
R	7.50	9.00	11.00	13.50	16.00	19.00
FF	8.00	9.00	10.50	11.50	13.00	14.00
Q (bore)	3.30	4.30	6.30	8.30	10.30	12.30
UU (bolt circle diameter)	6.00	7.50	9.50	11.75	14.25	17.00
B (number and size of holes)	4--.75	8--.75	8--.88	8--.88	12--1.00	12--1.00
Turns to open	11	14	20.5	26.5	33	38.5
Weight*	73	81	136	213	326	440
Closing Torque (FT-LBS), Non-Geared	52	75	110	150	185	225
Closing Torque (FT-LBS), Bevel	31	44	65	88	109	132
Closing Torque (FT-LBS), Spur	N/A	41	60	82	101	123

*All dimensions are in inches. All weights are in pounds and are approximate.

Rev. 7-19

- Catalog number
A-2361-12 Class 250 flanged ends
- Sizes – 3", 4", 6", 8", 10", 12"
- Meets or exceeds all applicable requirements of ANSI/AWWA C515*** Standard, UL 262 Listed, FM 1120/1130 Approved, and certified to ANSI/NSF 61 & 372
- Flanged end drilling complies with ASME/ANSI B16.1 Class 250
- Iron body with nominal 10 mils Mueller Pro-Guard® Fusion Bonded Epoxy Coated interior and exterior surfaces
- Epoxy coating meets or exceeds all applicable requirements of ANSI/AWWA C550 Standard
- Iron wedge, symmetrical and fully encapsulated with molded rubber; no exposed iron
- Non-rising stem (NRS)
- Triple O-ring seal (2 above the thrust collar and 1 below)
- 350 psig (2400 kPa/24 barg) maximum working pressure; 700 psig (4800 kPa/48 barg) static test pressure
- UL Listed, FM Approved: 350 psig (2400 kPa/24 barg)
- Designed for potable water applications

† Approved for backflow prevention devices by USC (for 4" - 10" sizes)



A-2361-12 shown

Options

See page 10.54 for more information on Resilient Wedge Gate Valve options

- Position indicators
- Stainless steel stem: Type 304, Type 316
- Low zinc, silicon bronze ASTM B98-C66100/H02 stem
- Handwheel
- P/N 25 Drilling
- EPDM Disc and O-rings

Resilient wedge gate valve parts

Catalog Part Number	Description	Material	Material Standard
G-16	Bonnet Bolts & Nuts	316 Stainless Steel	ASTM F593 (bolt) ASTM F594 (nut)
G-41	Stuffing Box Bolts & Nuts	316 Stainless Steel	ASTM F593 (bolt) ASTM F594 (nut)
G-49	Stem O-rings (3)	Nitrile	ASTM D2000
G-200	Wrench Nut Cap Screw	316 Stainless Steel	ASTM F593
G-201	Stuffing Box O-ring	Nitrile	ASTM D2000
G-202	Wrench Nut	Ductile Iron	ASTM A536 ▼
G-203	Stem	Bronze	ASTM B138
G-204	Hand Wheel (Not shown)	Cast Iron +	ASTM A126 CL.B
G-205	Stem Nut	Bronze	ASTM B584
G-206	Guide Cap Bearings	Acetal	-
G-207	Stuffing Box with dirt seal	Ductile Iron Nitrile	ASTM A536 ▼ ASTM D2000
G-208	Anti-friction Washers (2)	Acetal	-
G-209	Wedge, Rubber Encapsulation	Ductile Iron* SBR	ASTM A536 ▼ ASTM D2000
G-210	Bonnet	Ductile Iron	ASTM A536 ▼
G-211	Bonnet O-ring	Nitrile	ASTM D2000
G-212	Body	Ductile Iron	ASTM A536 ▼

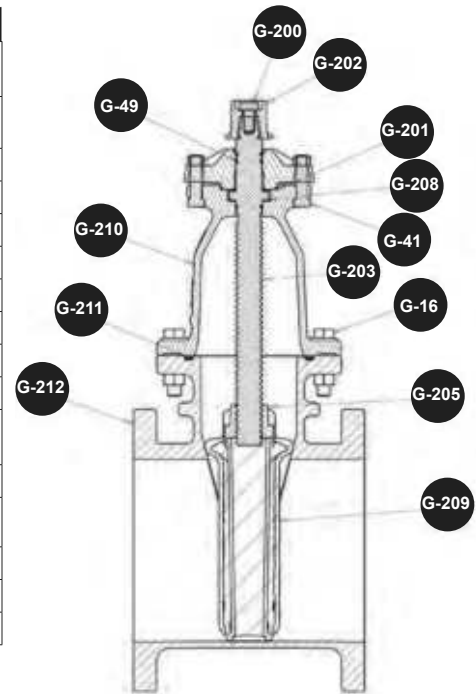

*Fully encapsulated in molded rubber with no iron exposed;

▼ Material strength ASTM A536 65-45 minimum

** Per ANSI/AWWA C111 working pressure above 250psi requires the use of a special gasket rated for higher pressure.

+ Manufacturer's option to change material to ductile iron ASTM A536

*** 3" valves meet or exceed all applicable requirements of ANSI/AWWA C509 Standard

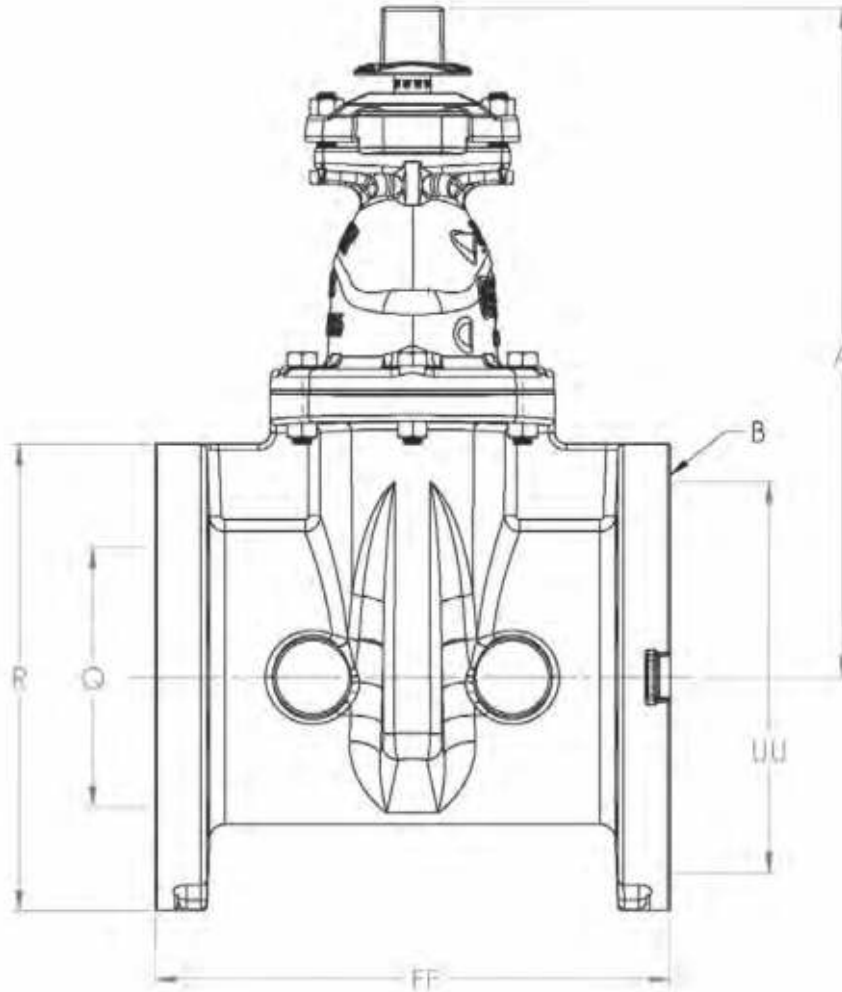

Dimensions

Dimension	Nominal Size					
	3"	4"	6"	8"	10"	12"
A	12.38	14.19	18.00	21.50	25.50	28.62
R	9.00	10.00	12.50	15.00	17.50	20.50
FF	11.10	12.00	15.88	16.50	18.00	19.75
Q (bore)	3.30	4.30	6.30	8.30	10.30	12.30
UU (bolt circle diameter)	6.63	7.87	10.63	12.99	15.24	17.76
B (number and size of holes)	8--.88	8--.88	12--.88	12--1.125	16--1.25	16--1.25
Turns to open	11	14	20.5	26.5	33	38.5
Weight*	75	106	184	291	453	592
Closing Torque (FT-LBS), Non-Geared	52	75	110	150	185	225
Closing Torque (FT-LBS), Bevel	31	44	65	88	109	132
Closing Torque (FT-LBS), Spur	N/A	41	60	82	101	123

*All dimensions are in inches. All weights are in pounds and are approximate.

Rev.1-22

- Catalog number **A-2361-70** HYMAX Grip® x HYMAX Grip®
- Sizes – 4", 6", 8", 10", 12"
- Non-rising stem (NRS)
- No assembly required
- Meets all applicable parts of ANSI/AWWA C515 Standard
- Fusion Bonded Epoxy coated interior and exterior surfaces, meets all applicable parts of ANSI/AWWA C550 Standard
- Certified to ANSI/NSF 61 & 372
- Iron wedge, symmetrical and fully encapsulated with molded rubber (no exposed iron)
- Triple O-ring seal (2 above the thrust collar and 1 below)
- 2" square wrench nut - open left or open right
- 250 psig (1724 kPa/17 bar) maximum working pressure; 500 psig (3447 kPa/34 bar) static test pressure
- Dynamic deflection up to 4 degrees per grip joint end
- Works with DI, CI, PVC, and HDPE pipe, per below:



A-2361-70 shown

Nominal Diameter (Inch)	Applicable Pipe OD Range (Inch)
4	4.48 - 5.02
6	6.61 - 7.12
8	8.60 - 9.35
10	10.73 - 11.49
12	12.68 - 13.29

Options

See page 10.54 for more information on Resilient Wedge Gate Valve options

- Position indicators
- Low zinc, silicon bronze ASTM B98-C66100/H02 stem
- Stainless steel stem: Type 304, Type 316
- Handwheel
- EPDM Disc and o-rings

Resilient wedge gate valve parts

Catalog Part Number	Description	Material	Material Standard
G-16	Bonnet Bolts & Nuts	316 Stainless Steel	ASTM F593 (bolt) ASTM F594 (nut)
G-41	Stuffing Box Bolts & Nuts	316 Stainless Steel	ASTM F593 (bolt) ASTM F594 (nut)
G-49	Stem O-rings (3)	Nitrile	ASTM D2000
G-200	Wrench Nut Cap Screw	316 Stainless Steel	ASTM F593
G-201	Stuffing Box O-ring	Nitrile	ASTM D2000
G-202	Wrench Nut	Ductile Iron	ASTMA536 ▼
G-203	Stem	Bronze	ASTM B138
G-204	Hand Wheel (not shown)	Cast Iron +	ASTM A126 CL.B
G-205	Stem Nut	Bronze	ASTM B584
G-206	Guide Cap Bearings	Acetal	-
G-207	Stuffing Box with dirt seal	Ductile Iron Nitrile	ASTMA536 ▼ ASTM D2000
G-208	Anti-friction Washers (2)	Acetal	-
G-209	Wedge, Rubber Encapsulation	Ductile Iron* SBR	ASTMA536 ▼ ASTM D2000
G-210	Bonnet	Ductile Iron	ASTMA536 ▼
G-211	Bonnet O-ring	Nitrile	ASTM D2000
G-212	Body	Ductile Iron	ASTMA536 ▼

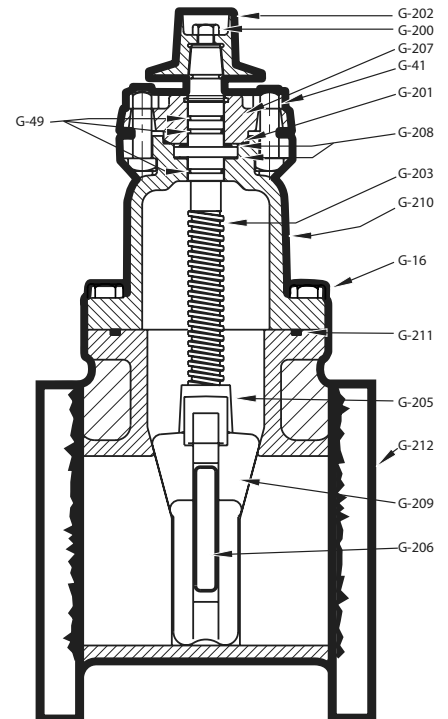

*Fully encapsulated in molded rubber with no iron exposed;
 ▼ Material strength ASTM A536 65-45 minimum
 + Manufacturer's option to change material to ductile iron ASTM A536

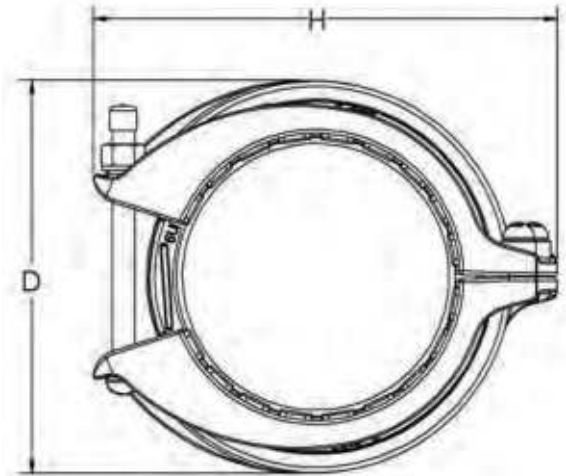
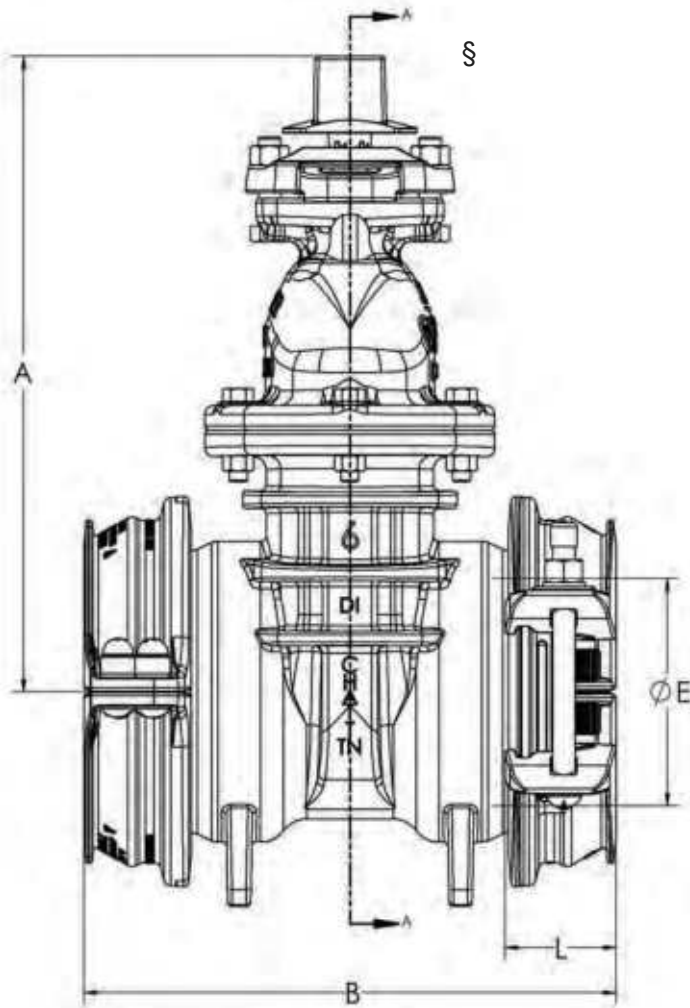

HYMAX GRIP® RESTRAINT ONLY

HYMAX GRIP® JOINT ENDS - HM x HM

Dimensions

Dimension	Nominal Size				
	4"	6"	8"	10"	12"
A	14.19	18.00	21.50	25.50	28.62
B	9.50	10.00	13.50	15.00	15.00
D	8.70	10.90	13.80	16.20	17.40
ØE	4.30	6.30	8.30	10.30	12.30
H	10.60	12.90	15.70	18.20	19.80
L	3.10	3.10	3.50	3.60	3.60
Turns to open	14	20.5	26.5	33	38.5
Weight*	70	118	187	276	330
Closing Torque (FT-LBS), Non-Geared	75	110	150	185	225
Closing Torque (FT-LBS), Bevel	44	65	88	109	132
Closing Torque (FT-LBS), Spur	41	60	82	101	123

* All dimensions are in inches. All weights include accessories are in pounds and are approximate.

Hymax Grip Restraint parts

ID	Description	Material	Material Standards
1	Nuts, Bolts, & Washers	304 Stainless Steel Rolled Thread & Anti-Galling coating	AISI 304 Stainless Steel
2	Spherical Spacers	304 Stainless Steel	ASTM A351 - CF8
3	Gasket Bridge	304 Stainless Steel	ASTM A240 / A480
4	End Ring	Ductile Iron	ASTM A536
5	Grippers	Advanced, Metal Injection Molding (MIM), hardened & coated	-
6	Gasket	EPDM	ASTM D2000

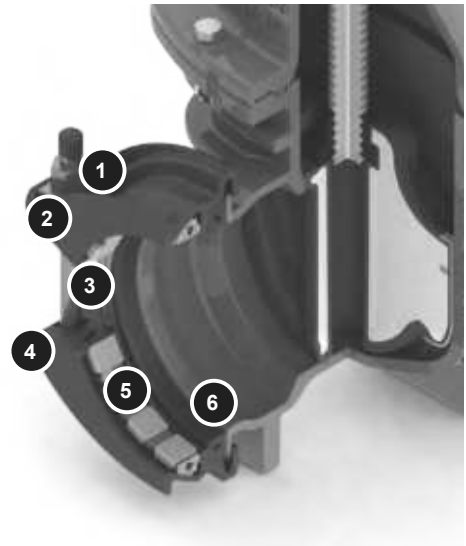

4" - 12" A-2361 RESILIENT WEDGE GATE VALVES - HYMAX GRIP® x FL.

MUELLER

10.13

Rev. 1-22

- Catalog number **A-2361-71** HYMAX Grip® x Flange Class 125
- Sizes – 4", 6", 8", 10", 12"
- Non-rising stem (NRS)
- No assembly required
- Meets all applicable parts of ANSI/AWWA C515 Standard
- Fusion Bonded Epoxy coated interior and exterior surfaces, meets all applicable parts of ANSI/AWWA C550 Standard
- Certified to ANSI/NSF 61 & 372
- Iron wedge, symmetrical and fully encapsulated with molded rubber (no exposed iron)
- Triple O-ring seal (2 above the thrust collar and 1 below)
- 2" square wrench nut - open left or open right
- 250 psig (1724 kPa/17 bar) maximum working pressure; 500 psig (3447 kPa/34 bar) static test pressure
- Dynamic deflection up to 4 degrees per grip joint end
- Works with DI, CI, PVC, and HDPE pipe, per below:



A-2361-71 shown

Nominal Diameter (Inch)	Applicable Pipe OD Range (Inch)
4	4.48 - 5.02
6	6.61 - 7.12
8	8.60 - 9.35
10	10.73 - 11.49
12	12.68 - 13.29

Options

See page 10.54 for more information on Resilient Wedge Gate Valve options

- Position indicators
- Low zinc, silicon bronze ASTM B98-C66100/H02 stem
- Stainless steel stem: Type 304, Type 316
- Handwheel
- EPDM Disc and o-rings

Resilient wedge gate valve parts

Catalog Part Number	Description	Material	Material Standard
G-16	Bonnet Bolts & Nuts	316 Stainless Steel	ASTM F593 (bolt) ASTM F594 (nut)
G-41	Stuffing Box Bolts & Nuts	316 Stainless Steel	ASTM F593 (bolt) ASTM F594 (nut)
G-49	Stem O-rings (3)	Nitrile	ASTM D2000
G-200	Wrench Nut Cap Screw	316 Stainless Steel	ASTM F593
G-201	Stuffing Box O-ring	Nitrile	ASTM D2000
G-202	Wrench Nut	Ductile Iron	ASTMA536 ▼
G-203	Stem	Bronze	ASTM B138
G-204	Hand Wheel (not shown)	Cast Iron +	ASTM A126 CL.B
G-205	Stem Nut	Bronze	ASTM B584
G-206	Guide Cap Bearings	Acetal	-
G-207	Stuffing Box with dirt seal	Ductile Iron SBR	ASTMA536 ▼ ASTM D2000
G-208	Anti-friction Washers (2)	Acetal	-
G-209	Wedge, Rubber Encapsulation	Ductile Iron* Nitrile	ASTMA536 ▼ ASTM D2000
G-210	Bonnet	Ductile Iron	ASTMA536 ▼
G-211	Bonnet O-ring	Nitrile	ASTM D2000
G-212	Body	Ductile Iron	ASTMA536 ▼

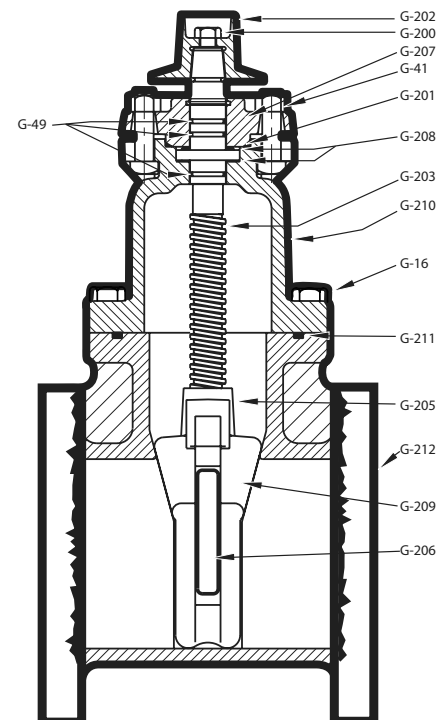

*Fully encapsulated in molded rubber with no iron exposed;

▼ Material strength ASTM A536 65-45 minimum

+ Manufacturer's option to change material to ductile iron ASTM A536

Rev.1-22

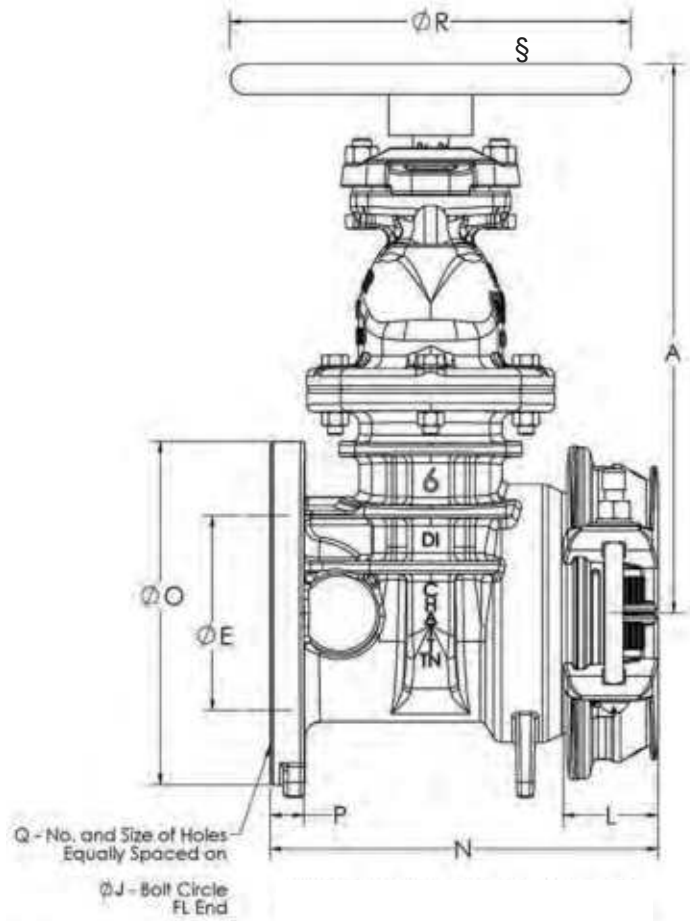

HYMAX GRIP® / FLANGE END - HM x FL

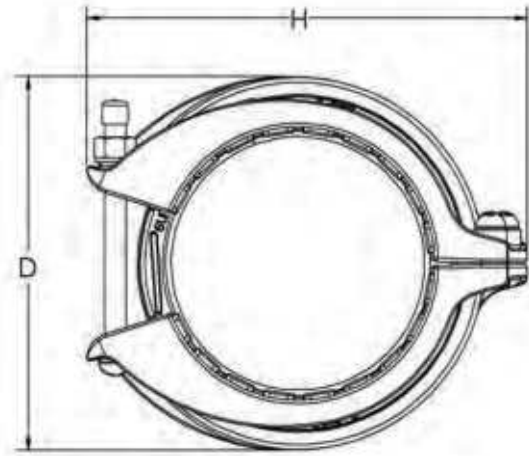

HYMAX GRIP® RESTRAINT ONLY

Dimensions

Dimension	Nominal Size				
	4"	6"	8"	10"	12"
A	14.19	18.00	21.50	25.50	28.62
D	8.70	10.90	13.80	16.20	17.40
H	10.60	12.90	15.70	18.20	19.80
ØE	4.30	6.30	8.30	10.30	12.30
L	3.10	3.10	3.50	3.60	3.60
N	9.30	10.25	12.54	14.00	14.53
O	9.00	11.25	13.50	16.00	19.00
P	1.00	1.13	1.15	1.29	1.33
ØR	11.00	13.00	14.00	16.00	16.00
Turns to open	14	20.5	26.5	33	38.5
Weight*	77	131	194	286	384
Q	4-0.88	6-0.88	6-0.88	8-0.88	8-0.88
ØJ	7.50	9.50	11.75	14.00	16.25
Closing Torque (FT-LBS), Non-Geared	75	110	150	185	225
Closing Torque (FT-LBS), Bevel	44	65	88	109	132
Closing Torque (FT-LBS), Spur	41	60	82	101	123

* All dimensions are in inches. All weights include accessories are in pounds and are approximate.

Hymax Grip Restraint parts

ID	Description	Material	Material Standards
1	Nuts, Bolts, & Washers	304 Stainless Steel Rolled Thread & Anti-Galling coating	AISI 304 Stainless Steel
2	Spherical Spacers	304 Stainless Steel	ASTM A351 - CF8
3	Gasket Bridge	304 Stainless Steel	ASTM A240 / A480
4	End Ring	Ductile Iron	ASTM A536
5	Grippers	Advanced, Metal Injection Molding (MIM), hardened & coated	-
6	Gasket	EPDM	ASTM D2000

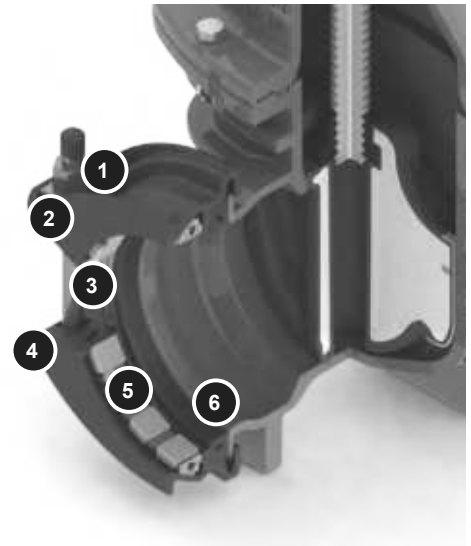

Rev. 4-20

- Catalog number
A-2361-10 Groove X Groove ends
- Sizes – 2"++, 2 1/2"++, 3", 4", 6", 8", 10", 12"
- Meets or exceeds all applicable requirements of ANSI/AWWA C515**** Standard, UL 262 Listed, FM 1120/130 Approved, and certified to ANSI/NSF 61 & 372
- Grooved ends comply with AWWA C606
- Iron body with nominal 10 mils Mueller Pro-Guard® Fusion Bonded Epoxy Coated interior and exterior surfaces
- Epoxy coating meets or exceeds all applicable requirements of ANSI/AWWA C550 Standard
- Iron wedge, symmetrical and fully encapsulated with molded rubber; no exposed iron
- Non-rising stem (NRS)
- Triple O-ring seal (2 above the thrust collar and 1 below)
- 2" square wrench nut - open left or open right
- 350 psig (2400 kPa/24 barg) maximum working pressure; 700 psig (4800 kPa/48 barg) static test pressure
- UL Listed, FM Approved – 350 psig (2400 kPa/24 barg)
- Designed for potable water applications



A-2361-10 shown

Options

See page 10.54 for more information on Resilient Wedge Gate Valve options

- Position indicators
- Low zinc, silicon bronze ASTM B98-C66100/H02 stem
- Stainless steel stem: Type 304, Type 316
- Handwheel
- EPDM Disc and o-rings

Resilient wedge gate valve parts

Catalog Part Number	Description	Material	Material Standard
G-16	Bonnet Bolts & Nuts	316 Stainless Steel	ASTM F593 (bolt) ASTM F594 (nut)
G-41	Stuffing Box Bolts & Nuts	316 Stainless Steel	ASTM F593 (bolt) ASTM F594 (nut)
G-49	Stem O-rings (3)	Nitrile	ASTM D2000
G-200	Wrench Nut Cap Screw	316 Stainless Steel	ASTM F593
G-201	Stuffing Box O-ring	Nitrile	ASTM D2000
G-202	Wrench Nut	Ductile Iron	ASTM A536 ▼
G-203	Stem	Bronze	ASTM B138
G-204	Hand Wheel (not shown)	Cast Iron +	ASTM A126 CL.B
G-205	Stem Nut	Bronze	ASTM B584
G-206	Guide Cap Bearings	Acetal	-
G-207	Stuffing Box with dirt seal	Ductile Iron Nitrile	ASTM A536 ▼ ASTM D2000
G-208	Anti-friction Washers (2)	Acetal	-
G-209	Wedge, Rubber Encapsulation	Ductile Iron* SBR	ASTM A536 ▼ ASTM D2000
G-210	Bonnet	Ductile Iron	ASTM A536 ▼
G-211	Bonnet O-ring+++	Nitrile	ASTM D2000
G-212	Body	Ductile Iron	ASTM A536 ▼

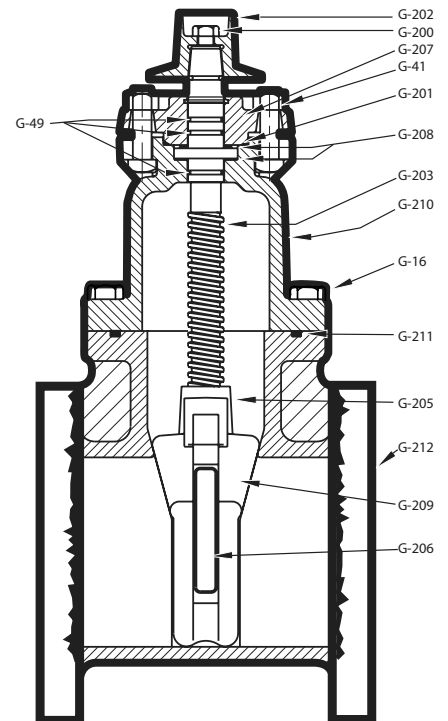

*Fully encapsulated in molded rubber with no iron exposed;

▼ Material strength ASTM A536 65-45 minimum

** Per ANSI/AWWA C111 working pressure above 250psi requires the use of a special gasket rated for higher pressure.

+ Manufacturer's option to change material to ductile iron ASTM A536

*** 3" valves meet or exceed all applicable requirements of ANSI/AWWA C509 Standard

++ 2" & 2 1/2" valves are model A2362

+++ 2" & 2 1/2" valves have a bonnet gasket

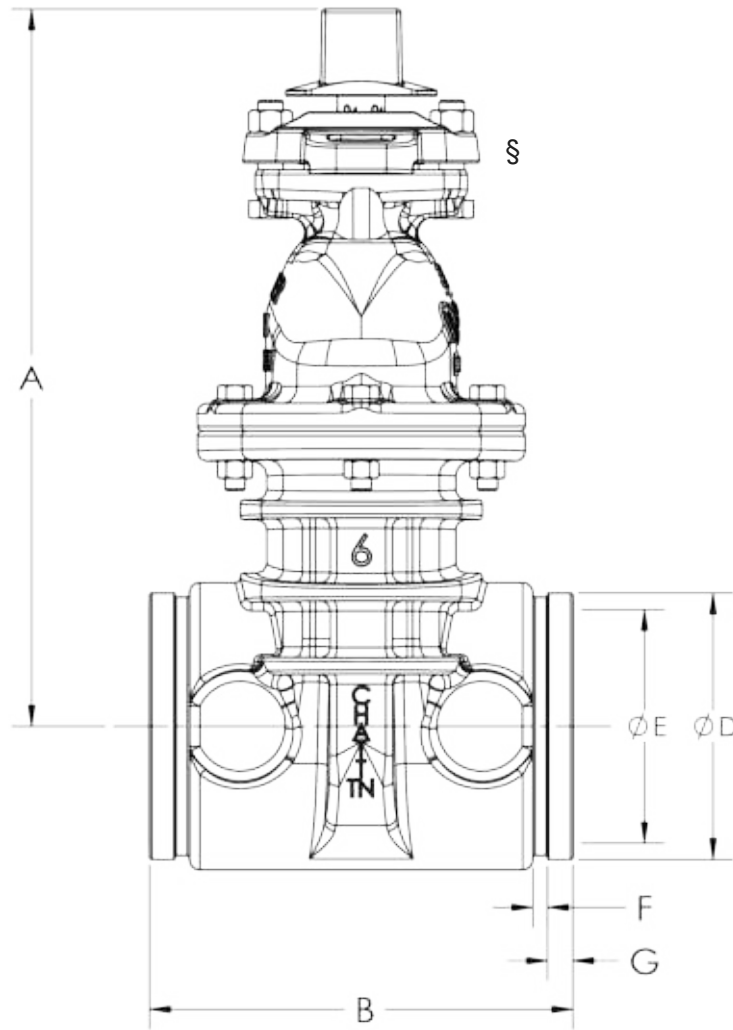

Dimensions

Dimension	Nominal Size							
	2"	2 1/2"	3"	4"	6"	8"	10"	12"
A	9.88	12.38	12.38	14.19	18.00	21.50	25.50	28.62
B	7.00	7.50	8.00	9.00	10.50	11.50	13.00	14.00
C* (overall width of bonnet flange)	7.00	8.63	8.63	10.79	13.50	16.36	20.00	21.00
ØE (bore)	1.56	1.97	2.63	3.75	5.80	7.67	9.80	11.80
F	0.34	0.34	0.34	0.34	0.34	0.47	0.47	0.47
G	0.63	0.63	0.63	0.63	0.63	0.75	0.75	0.75
ØD	2.38	2.88	3.50	4.50	6.63	8.63	10.75	12.75
Turns to open	8	11	11	14	20.5	26.5	33	38.5
Weight*	37	44	48	64	114	163	247	315
Closing Torque (FT-LBS), Non-Geared	20	28	52	75	110	150	185	225
Closing Torque (FT-LBS), Bevel	N/A	N/A	31	44	65	88	109	132
Closing Torque (FT-LBS), Spur	N/A	N/A	N/A	41	60	82	101	123

* All dimensions are in inches. All weights include accessories are in pounds and are approximate.

Rev. 7-19

- Catalog number
A-2361-11 groove x flanged ends
- Sizes – 2"++, 2 1/2"++, 3", 4", 6", 8", 10", 12"
- Meets or exceeds all applicable requirements of ANSI/AWWA C515*** Standard, UL 262 Listed, FM 1120/130 Approved, and certified to ANSI/NSF 61 & 372
- Flanged end drilling complies with ASME/ANSI B16.1 Class 125**
- Groove end complies with AWWA C606
- Iron body with nominal 10 mils Mueller Pro-Guard® Fusion Bonded Epoxy Coated interior and exterior surfaces
- Epoxy coating meets or exceeds all applicable requirements of ANSI/AWWA C550 Standard
- Iron wedge, symmetrical and fully encapsulated with molded rubber; no exposed iron
- Non-rising stem (NRS)
- Triple O-ring seal (2 above the thrust collar and 1 below)
- 2" square wrench nut - open left or open right
- 350 psig (2400 kPa/24 barg) maximum working pressure; 700 psig (4800 kPa/48 barg) static test pressure
- UL Listed, FM Approved – 350 psig (2400 kPa/24 barg)
- Designed for potable water applications



A-2361-11 shown

Options

See page 10.54 for more information on Resilient Wedge Gate Valve options

- Position indicators
- Stainless steel stem: Type 304, Type 316
- EPDM Disc and o-rings
- Low zinc, silicon bronze ASTM B98-C66100/H02 stem
- Handwheel

Resilient wedge gate valve parts

Catalog Part Number	Description	Material	Material Standard
G-16	Bonnet Bolts & Nuts	316 Stainless Steel	ASTM F593 (bolt) ASTM F594 (nut)
G-41	Stuffing Box Bolts & Nuts	316 Stainless Steel	ASTM F593 (bolt) ASTM F594 (nut)
G-49	Stem O-rings (3)	Nitrile	ASTM D2000
G-200	Wrench Nut Cap Screw	316 Stainless Steel	ASTM F593
G-201	Stuffing Box O-ring	Nitrile	ASTM D2000
G-202	Wrench Nut	Ductile Iron	ASTM A536 ▼
G-203	Stem	Bronze	ASTM B138
G-204	Hand Wheel (not shown)	Cast Iron +	ASTM A126 CL.B
G-205	Stem Nut	Bronze	ASTM B584
G-206	Guide Cap Bearings	Acetal	-
G-207	Stuffing Box with dirt seal	Ductile Iron Nitrile	ASTM A536 ▼ ASTM D2000
G-208	Anti-friction Washers (2)	Acetal	-
G-209	Wedge, Rubber Encapsulation	Ductile Iron* SBR	ASTM A536 ▼ ASTM D2000
G-210	Bonnet	Ductile Iron	ASTM A536 ▼
G-211	Bonnet O-ring+++	Nitrile	ASTM D2000
G-212	Body	Ductile Iron	ASTM A536 ▼

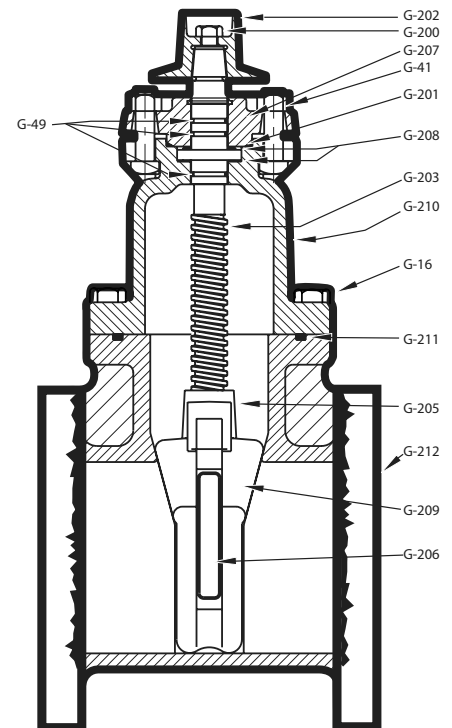

*Fully encapsulated in molded rubber with no iron exposed;

▼ Material strength ASTM A536 65-45 minimum

** Per ANSI/AWWA C111 working pressure above 250psi requires the use of a special gasket rated for higher pressure.

+ Manufacturer's option to change material to ductile iron ASTM A536

*** 3" valves meet or exceed all applicable requirements of ANSI/AWWA C509 Standard

++ 2" & 2 1/2" valves are model A2362

+++ 2" & 2 1/2" valves have a bonnet gasket

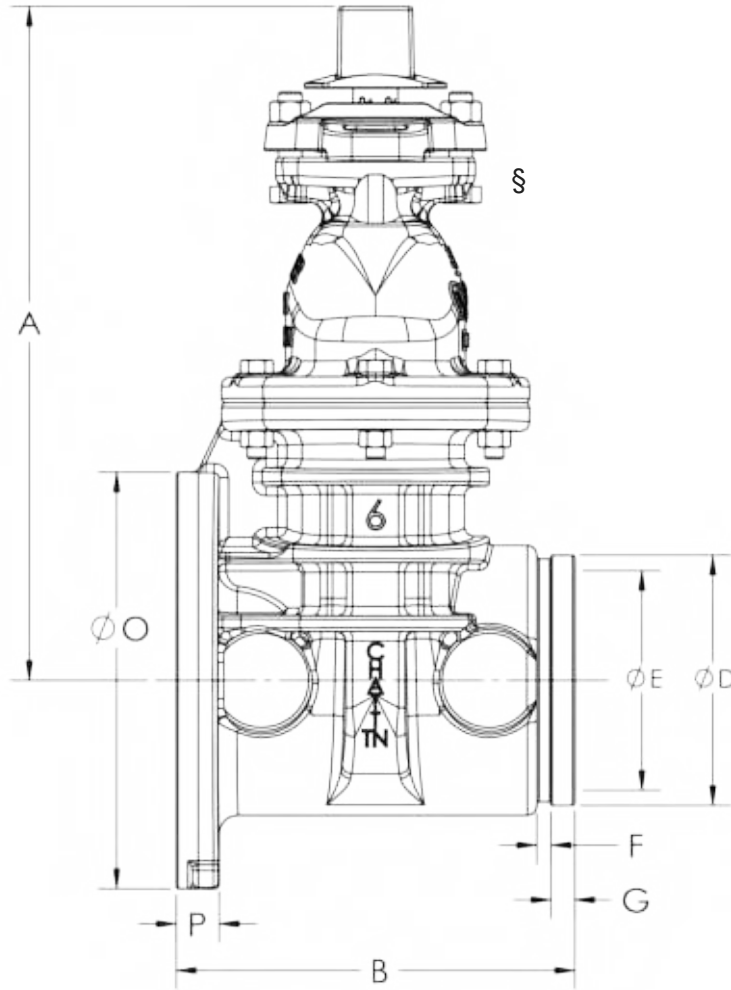

Dimensions

Dimension	Nominal Size							
	2"	2 1/2"	3"	4"	6"	8"	10"	12"
A	9.88	12.38	12.38	14.19	18.00	21.50	25.50	28.62
B	7.00	7.50	8.00	9.00	10.50	11.50	13.00	14.00
C* (overall width of bonnet flange)	7.00	8.63	8.63	10.79	13.50	16.36	20.00	21.00
ØD	2.38	2.88	3.50	4.50	6.63	8.63	10.75	12.75
ØE (bore)	1.56	1.97	2.63	3.75	5.80	7.67	9.80	11.80
F	0.34	0.34	0.34	0.34	0.34	0.47	0.47	0.47
G	0.63	0.63	0.63	0.63	0.63	0.75	0.75	0.75
P	0.69	0.75	0.81	1.00	1.06	1.19	1.25	1.31
ØO	6.00	7.00	7.50	9.00	11.00	13.50	16.00	19.00
NO-ØK (number-size holes)	4--.63	4--.75	4--.75	8--.75	8--.88	8--.88	12--1.00	12--1.00
ØR (bolt circle)	4.75	5.50	6.00	7.50	9.50	11.75	14.25	17.00
Turns to open	8	11	11	14	20.5	26.5	33	38.5
Weight*	41	50	56	75	129	190	278	370
Closing Torque (FT-LBS), Non-Geared	20	28	52	75	110	150	185	225
Closing Torque (FT-LBS), Bevel	N/A	N/A	31	44	65	88	109	132
Closing Torque (FT-LBS), Spur	N/A	N/A	N/A	41	60	82	101	123

* All dimensions are in inches. All weights include accessories are in pounds and are approximate.

Rev. 7-19

- Catalog number
A-2361-16 mechanical joint x flanged ends (with accessories unassembled)
A-2361-19 mechanical joint x flanged ends (less accessories)
- Sizes – 3", 4", 6", 8", 10", 12"
- Meets or exceeds all applicable requirements of ANSI/AWWA C515*** Standard, UL 262 Listed, FM 1120/130 Approved, and certified to ANSI/NSF 61 & 372
- Flanged end drilling complies with ASME/ANSI B16.1 Class 125**
- Mechanical joint end complies with ANSI/AWWA C111 Standard
- Iron body with nominal 10 mils Mueller Pro-Guard® Fusion Bonded Epoxy Coated interior and exterior surfaces
- Epoxy coating meets or exceeds all applicable requirements of ANSI/AWWA C550 Standard
- Iron wedge, symmetrical and fully encapsulated with molded rubber; no exposed iron
- Non-rising stem (NRS)
- Triple O-ring seal (2 above the thrust collar and 1 below)
- 2" square wrench nut - open left or open right
- 350 psig (2400 kPa/24 barg) maximum working pressure; 700 psig (4800 kPa/48 barg) static test pressure
- UL Listed, FM Approved – 350 psig (2400 kPa/24 barg)
- Designed for potable water applications



A-2361-16 shown
M.J. accessories shipped unassembled

Options

See page 10.54 for more information on Resilient Wedge Gate Valve options

- Position indicators
- Low zinc, silicon bronze ASTM B98-C66100/H02 stem
- Stainless steel stem: Type 304, Type 316
- Handwheel
- EPDM Disc and o-rings

Resilient wedge gate valve parts

Catalog Part Number	Description	Material	Material Standard
G-16	Bonnet Bolts & Nuts	316 Stainless Steel	ASTM F593 (bolt) ASTM F594 (nut)
G-41	Stuffing Box Bolts & Nuts	316 Stainless Steel	ASTM F593 (bolt) ASTM F594 (nut)
G-49	Stem O-rings (3)	Nitrile	ASTM D2000
G-200	Wrench Nut Cap Screw	316 Stainless Steel	ASTM F593
G-201	Stuffing Box O-ring	Nitrile	ASTM D2000
G-202	Wrench Nut	Ductile Iron	ASTM A536 ▼
G-203	Stem	Bronze	ASTM B138
G-204	Hand Wheel (not shown)	Cast Iron +	ASTM A126 CL.B
G-205	Stem Nut	Bronze	ASTM B584
G-206	Guide Cap Bearings	Acetal	-
G-207	Stuffing Box with dirt seal	Ductile Iron Nitrile	ASTM A536 ▼ ASTM D2000
G-208	Anti-friction Washers (2)	Acetal	-
G-209	Wedge, Rubber Encapsulation	Ductile Iron* SBR	ASTM A536 ▼ ASTM D2000
G-210	Bonnet	Ductile Iron	ASTM A536 ▼
G-211	Bonnet O-ring +++	Nitrile	ASTM D2000
G-212	Body	Ductile Iron	ASTM A536 ▼

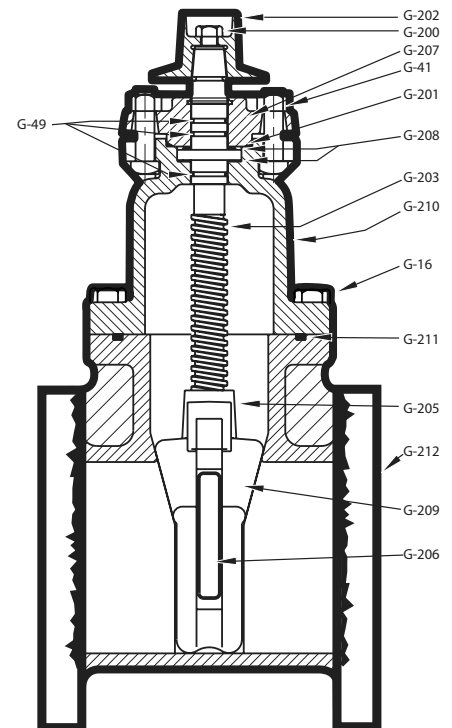

+++ 3" valves use a bonnet gasket

*Fully encapsulated in molded rubber with no iron exposed;

▼ Material strength ASTM A536 65-45 minimum

** Per ANSI/AWWA C111 working pressure above 250psi requires the use of a special gasket rated for higher pressure.

+ Manufacturer's option to change material to ductile iron ASTM A536

*** 3" valves meet or exceed all applicable requirements of ANSI/AWWA C509 Standard

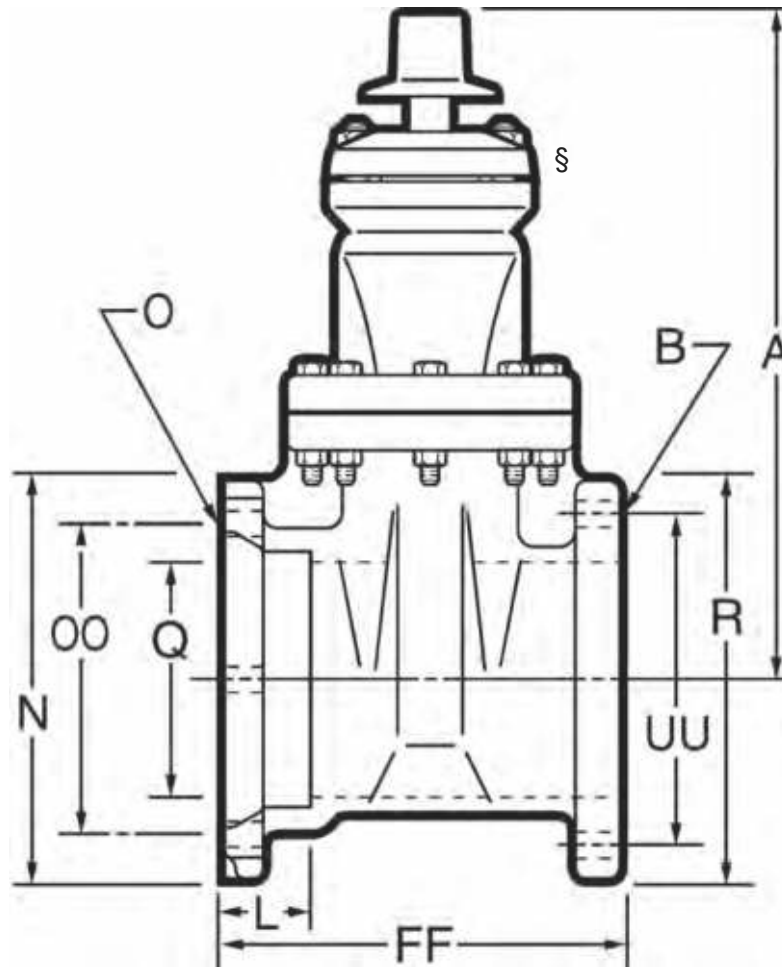

Dimensions

Dimension	Nominal Size					
	3"	4"	6"	8"	10"	12"
A	12.38	14.19	18.00	21.50	25.50	28.62
L	2.50	2.50	2.50	2.50	2.50	2.50
N	7.50	9.12	11.12	13.37	15.62	17.88
O	4--.88	4--.88	6--.88	6--.88	8--.88	8--.88
Q (bore)	3.30	4.30	6.30	8.30	10.30	12.30
OO (bolt circle diameter)	6.19	7.50	9.50	11.75	14.00	16.25
R (number and size of holes)	7.50	9.00	11.00	13.50	16.00	19.00
UU	5.50	7.50	9.50	11.75	14.25	17.00
FF	8.80	9.50	11.06	12.09	13.94	14.50
B	4--.75	8--.75	8--.88	8--.88	12--1.00	12--1.00
Turns to open	11	14	20.5	26.5	33	38.5
Weight*	67	80	136	198	299	398
Closing Torque (FT-LBS), Non-Geared	52	75	110	150	185	225
Closing Torque (FT-LBS), Bevel	31	44	65	88	109	132
Closing Torque (FT-LBS), Spur	N/A	41	60	82	101	123

* All dimensions are in inches. All weights include accessories are in pounds and are approximate.

Rev. 4-20

- Catalog number
A-2361-38 Slip-on† ends with gasket
A-2361-40 Slip-on† ends less gasket
- Sizes – 4", 6", 8", 10", 12"
- Meets or exceeds all applicable requirements of ANSI/AWWA C515 Standard, UL 262 Listed, FM 1120/1130 Approved, and certified to ANSI/NSF 61 & 372
- Slip-on ends fit plain end of classes 150, 200 and 250 cast iron; ductile iron and classes 150 and 200 cast iron O.D. PVC
- Iron body with nominal 10 mils Mueller Pro-Gard® Fusion Bonded Epoxy Coated interior and exterior surfaces
- Epoxy coating meets or exceeds all applicable requirements of ANSI/AWWA C550 Standard
- Iron wedge, symmetrical and fully encapsulated with molded rubber; no exposed iron
- Non-rising stem (NRS)
- Triple O-ring seal (2 above the thrust collar and 1 below)
- 2" square wrench nut - open left or open right
- 350 psig (2400 kPa/24 barg) maximum working pressure; 700 psig (4800 kPa/48 barg) static test pressure
- UL Listed, FM Approved: 350 psig (2400 kPa/24 barg)
- Designed for potable water applications

†Design and dimensions of the joint are manufactured under license of U.S. Pipe and Foundry Company.
 ††Field Lok is a trademark of U.S. Pipe Valve & Hydrant, LLC and Foundry Company, used with permission.



A-2361-38 shown

Slip-on ends on this valve are not intended for use with Field Lok†† restrained gaskets. Use valve on page 10.13A

Options

See page 10.54 for more information on Resilient Wedge Gate Valve options

- Position indicators
- Stainless steel stem: Type 304, Type 316
- EPDM Disc and o-rings
- Low zinc, silicon bronze ASTM B98-C66100/H02 stem
- Handwheel

Resilient wedge gate valve parts

Catalog Part Number	Description	Material	Material Standard
G-16	Bonnet Bolts & Nuts	316 Stainless Steel	ASTM F593 (bolt) ASTM F594 (nut)
G-41	Stuffing Box Bolts & Nuts	316 Stainless Steel	ASTM F593 (bolt) ASTM F594 (nut)
G-49	Stem O-rings (3)	Nitrile	ASTM D2000
G-200	Wrench Nut Cap Screw	316 Stainless Steel	ASTM F593
G-201	Stuffing Box O-ring	Nitrile	ASTM D2000
G-202	Wrench Nut	Ductile Iron	ASTM A536 ▼
G-203	Stem	Bronze	ASTM B138
G-204	Hand Wheel (not shown)	Cast Iron +	ASTM A126 CL.B
G-205	Stem Nut	Bronze	ASTM B584
G-206	Guide Cap Bearings	Acetal	-
G-207	Stuffing Box with dirt seal	Ductile Iron Nitrile	ASTM A536 ▼ ASTM D2000
G-208	Anti-friction Washers (2)	Acetal	-
G-209	Wedge, Rubber Encapsulation	Ductile Iron SBR*	ASTM A536 ▼ ASTM D2000
G-210	Bonnet	Ductile Iron	ASTM A536 ▼
G-211	Bonnet O-ring	Nitrile	ASTM D2000
G-212	Body	Ductile Iron	ASTM A536 ▼

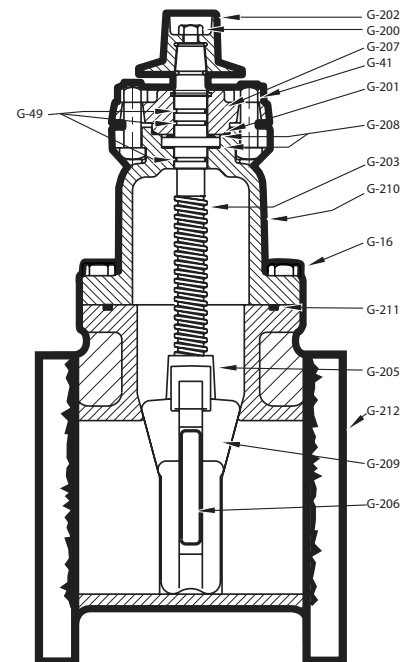

*Fully encapsulated in molded rubber with no iron exposed

▼ Material strength ASTM A536 65-45 minimum

+ Manufacturer's option to change material to ductile iron ASTM A536

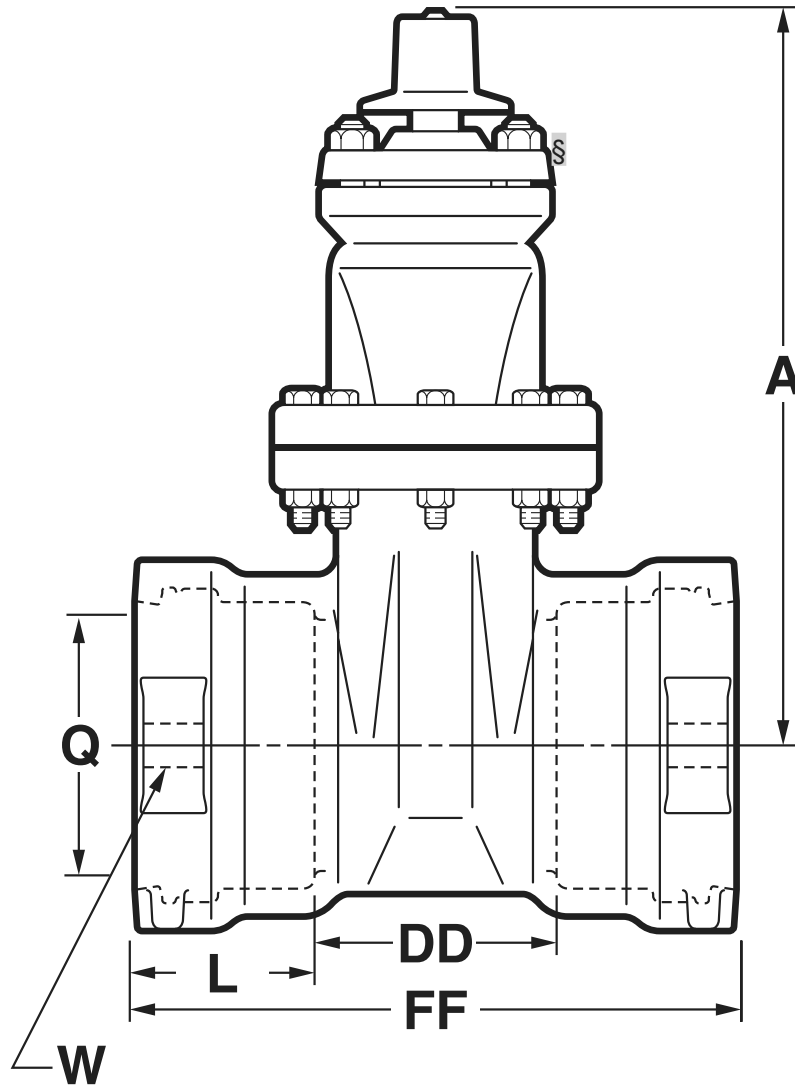

Dimensions

Dimension	Nominal Size				
	4"	6"	8"	10"	12"
A	14.19	18.00	21.50	25.50	28.62
Q (bore)	4.30	6.30	8.30	10.30	12.30
L	4.12	4.38	5.62	5.62	5.62
R	9.00	11.00	13.50	16.00	19.00
UU (bolt circle diameter for FL)	7.50	9.50	11.75	14.25	17.00
B (number and size of holes for FL)	8--.75	8--.88	8--.88	12--1.00	12--1.00
W (distance between strapping lug holes across face of valve ends)	8.62	10.62	13.12	16.38	18.12
FF	10.91	12.73	14.72	15.75	16.35
Turns to open	14	20.5	26.5	33	38.5
Weight*	93	140	241	368	523
Closing Torque (FT-LBS), Non-Geared	75	110	150	185	225
Closing Torque (FT-LBS), Bevel	44	65	88	109	132
Closing Torque (FT-LBS), Spur	41	60	82	101	123

*All dimensions are in inches. All weights are in pounds and are approximate.

Rev. 7-17

- Catalog number
A-2361-41 Slip-on† end (with gasket) x flange end
A-2361-43 Slip-on† end (less gasket) x flange end
- Sizes – 4", 6", 8", 10", 12"
- Meets or exceeds all applicable requirements of ANSI/AWWA C515 Standard, UL 262 Listed, FM 1120/1130 Approved, and certified to ANSI/NSF 61 & 372
- Slip-on ends fit plain end of classes 150, 200 and 250 cast iron, ductile iron and classes 150 and 200 cast iron O.D. PVC
- Flange end drilling complies with ASME/ANSI B16.1 Class 125**
- Iron body with nominal 10 mils Mueller Pro-Gard® Fusion Bonded Epoxy Coated interior and exterior surfaces
- Epoxy coating meets or exceeds all applicable requirements of ANSI/AWWA C550 Standard
- Iron wedge, symmetrical and fully encapsulated with molded rubber; no exposed iron
- Non-rising stem (NRS)
- Triple O-ring seal (2 above the thrust collar and 1 below)
- 2" square wrench nut – open left or open right
- 350 psig (2400 kPa/24 barg) maximum working pressure; 700 psig (4800 kPa/48 barg) static test pressure
- UL Listed, FM Approved: 350 psig (2400 kPa/24 barg)
- Designed for potable water applications



§

A-2361-41 shown

Slip-on end on this valve is not intended for use with Field Lok†† restrained gaskets. Use valve on page 10.13C

†Design and dimensions of the joint are manufactured under license of U.S. Pipe and Foundry Company.
 ††Field Lok is a trademark of U.S. Pipe and Foundry Company, used with permission.

Options

See page 10.54 for more information on Resilient Wedge Gate Valve options

- Position indicators
- Low zinc, silicon bronze ASTM B98-C66100/H02 stem
- Stainless steel stem: Type 304, Type 316
- Handwheel
- EPDM Disc and o-rings

Resilient wedge gate valve parts

Catalog Part Number	Description	Material	Material Standard
G-16	Bonnet Bolts & Nuts	316 Stainless Steel	ASTM F593 (bolt) ASTM F594 (nut)
G-41	Stuffing Box Bolts & Nuts	316 Stainless Steel	ASTM F593 (bolt) ASTM F594 (nut)
G-49	Stem O-rings (3)	Nitrile	ASTM D2000
G-200	Wrench Nut Cap Screw	316 Stainless Steel	ASTM F593
G-201	Stuffing Box O-ring	Nitrile	ASTM D2000
G-202	Wrench Nut	Ductile Iron	ASTM A536 ▼
G-203	Stem	Bronze	ASTM B138
G-204	Hand Wheel (not shown)	Cast Iron +	ASTM A126 CL.B
G-205	Stem Nut	Bronze	ASTM B584
G-206	Guide Cap Bearings	Acetal	-
G-207	Stuffing Box with dirt seal	Ductile Iron Nitrile	ASTM A536 ▼ ASTM D2000
G-208	Anti-friction Washers (2)	Acetal	-
G-209	Wedge, Rubber Encapsulation	Ductile Iron* SBR	ASTM A536 ▼ ASTM D2000
G-210	Bonnet	Ductile Iron	ASTM A536 ▼
G-211	Bonnet O-ring	Nitrile	ASTM D2000
G-212	Body	Ductile Iron	ASTM A536 ▼

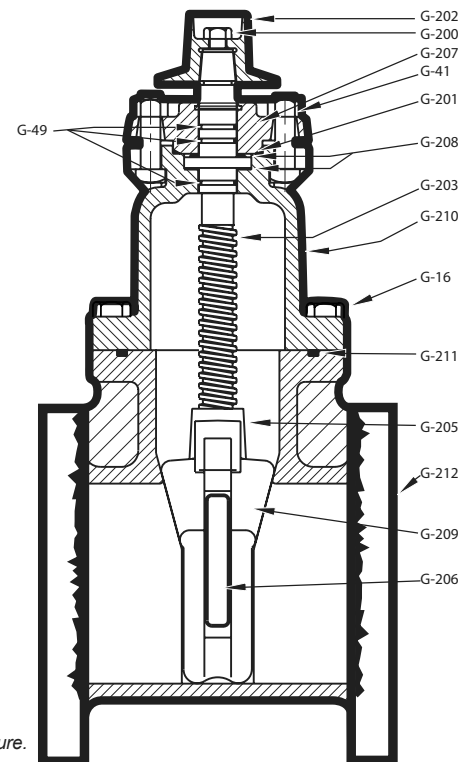

*Fully encapsulated in molded rubber with no iron exposed

▼ Material strength ASTM A536 65-45 minimum

** Per ANSI/AWWA C111 working pressure above 250psi requires the use of a special gasket rated for higher pressure.

+ Manufacturer's option to change material to ductile iron ASTM A536

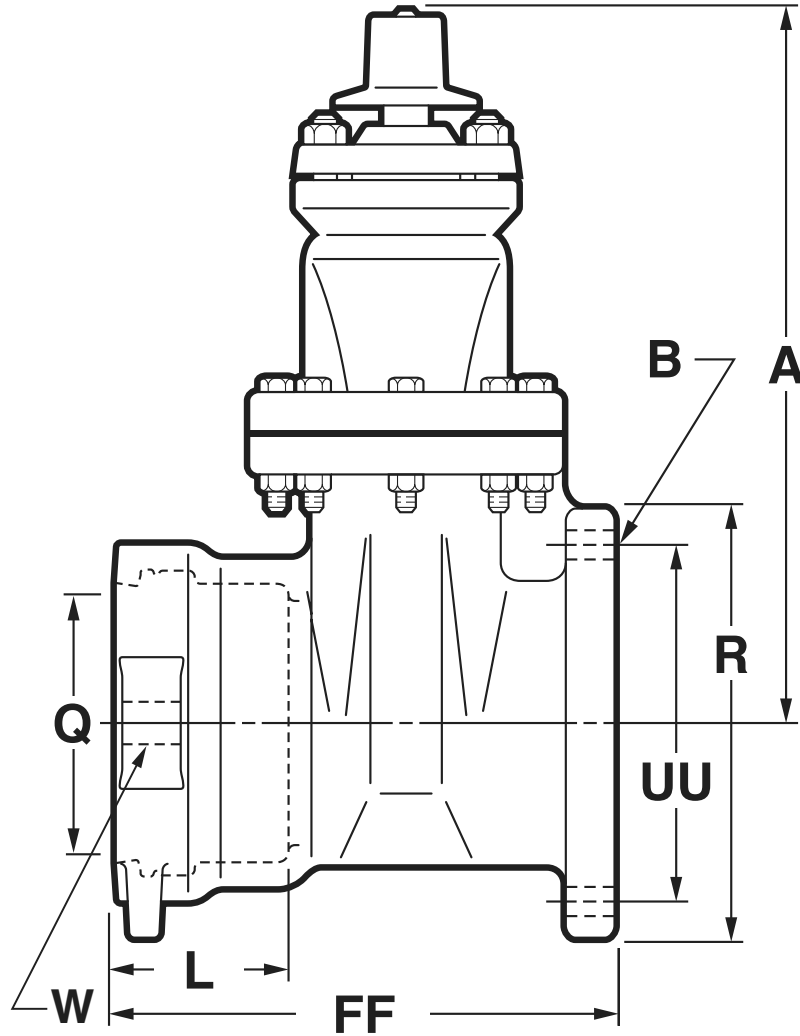

Dimensions

Dimension	Nominal Size				
	4"	6"	8"	10"	12"
A	14.19	18.00	21.50	25.50	28.62
Q (bore)	4.30	6.30	8.30	10.30	12.30
L	4.12	4.38	5.62	5.62	5.62
R	9.00	11.00	13.50	16.00	19.00
UU (bolt circle diameter for FL)	7.50	9.50	11.75	14.25	17.00
B (number and size of holes for FL)	8--.75	8--.88	8--.88	12--1.00	12--1.00
W (distance between strapping lug holes across face of valve ends)	8.62	10.62	13.12	16.38	18.12
FF	10.91	12.73	14.72	15.75	16.35
Turns to open	14	20.5	26.5	33	38.5
Weight*	93	140	241	368	523
Closing Torque (FT-LBS), Non-Geared	75	110	150	185	225
Closing Torque (FT-LBS), Bevel	44	65	88	109	132
Closing Torque (FT-LBS), Spur	41	60	82	101	123

*All dimensions are in inches. All weights are in pounds and are approximate.

Rev. 7-17

- Catalog number
A-2361-61 Slip On ends (less Field Lok gaskets)
- Sizes – 4", 6", 8", 12"
- Meets or exceeds all applicable requirements of ANSI/AWWA C515 Standard, UL 262 Listed, FM 1120/1130 Approved, and certified to ANSI/NSF 61 & 372
- Slip-on ends with Field Lok gaskets are to be used on ductile iron pipe
- Iron body with nominal 10 mils Mueller Pro-Gard® Fusion Bonded Epoxy Coated interior and exterior surfaces
- Epoxy coating meets or exceeds all applicable requirements of ANSI/AWWA C550 Standard
- Iron wedge, symmetrical and fully encapsulated with molded rubber; no exposed iron
- Non-rising stem (NRS)
- Triple O-ring seal (2 above the thrust collar and 1 below)
- 2" square wrench nut – open left or open right
- 350 psig (2400 kPa/24 barg) maximum working pressure; 700 psig (4800 kPa/48 barg) static test pressure
- UL Listed, FM Approved: 350 psig (2400 kPa/24 barg)
- Designed for potable water applications

†Design and dimensions of the joint are manufactured under license of U.S. Pipe and Foundry Company.

††Field Lok is a trademark of U.S. Pipe and Foundry Company, used with permission.



A-2361-61 shown

Slip-on ends on this valve are intended for use with Field Lok†† restrained gaskets.

Options

See page 10.54 for more information on Resilient Wedge Gate Valve options

- Position indicators
- Stainless steel stem: Type 304, Type 316
- EPDM Disc and o-rings
- Low zinc, silicon bronze ASTM B98-C66100/H02 stem
- Handwheel

Resilient wedge gate valve parts

Catalog Part Number	Description	Material	Material Standard
G-16	Bonnet Bolts & Nuts	316 Stainless Steel	ASTM F593 (bolt) ASTM F594 (nut)
G-41	Stuffing Box Bolts & Nuts	316 Stainless Steel	ASTM F593 (bolt) ASTM F594 (nut)
G-49	Stem O-rings (3)	Nitrile	ASTM D2000
G-200	Wrench Nut Cap Screw	316 Stainless Steel	ASTM F593
G-201	Stuffing Box O-ring	Nitrile	ASTM D2000
G-202	Wrench Nut	Ductile Iron	ASTMA536 ▼
G-203	Stem	Bronze	ASTM B138
G-204	Hand Wheel (not shown)	Cast Iron +	ASTM A126 CL.B
G-205	Stem Nut	Bronze	ASTM B584
G-206	Guide Cap Bearings	Acetal	-
G-207	Stuffing Box with dirt seal	Ductile Iron Nitrile	ASTMA536 ▼ ASTM D2000
G-208	Anti-friction Washers (2)	Acetal	-
G-209	Wedge, Rubber Encapsulation	Ductile Iron* SBR	ASTMA536 ▼ ASTM D2000
G-210	Bonnet	Ductile Iron	ASTMA536 ▼
G-211	Bonnet O-ring	Nitrile	ASTM D2000
G-212	Body	Ductile Iron	ASTMA536 ▼

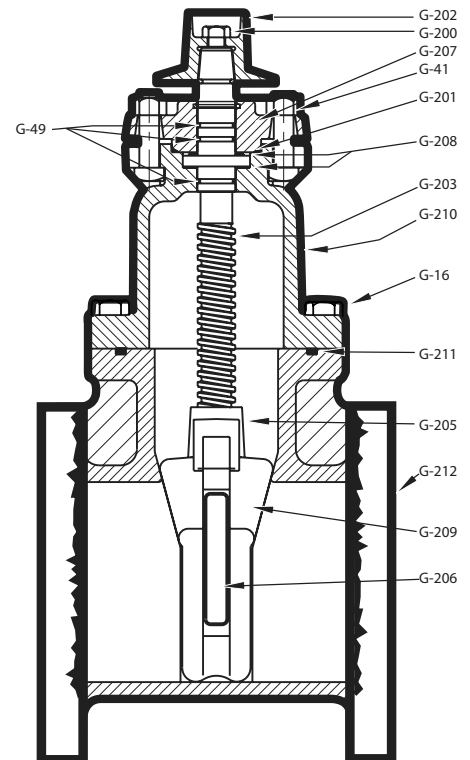

*Fully encapsulated in molded rubber with no iron exposed

▼ Material strength ASTM A536 65-45 minimum

+ Manufacturer's option to change material to ductile iron ASTM A536

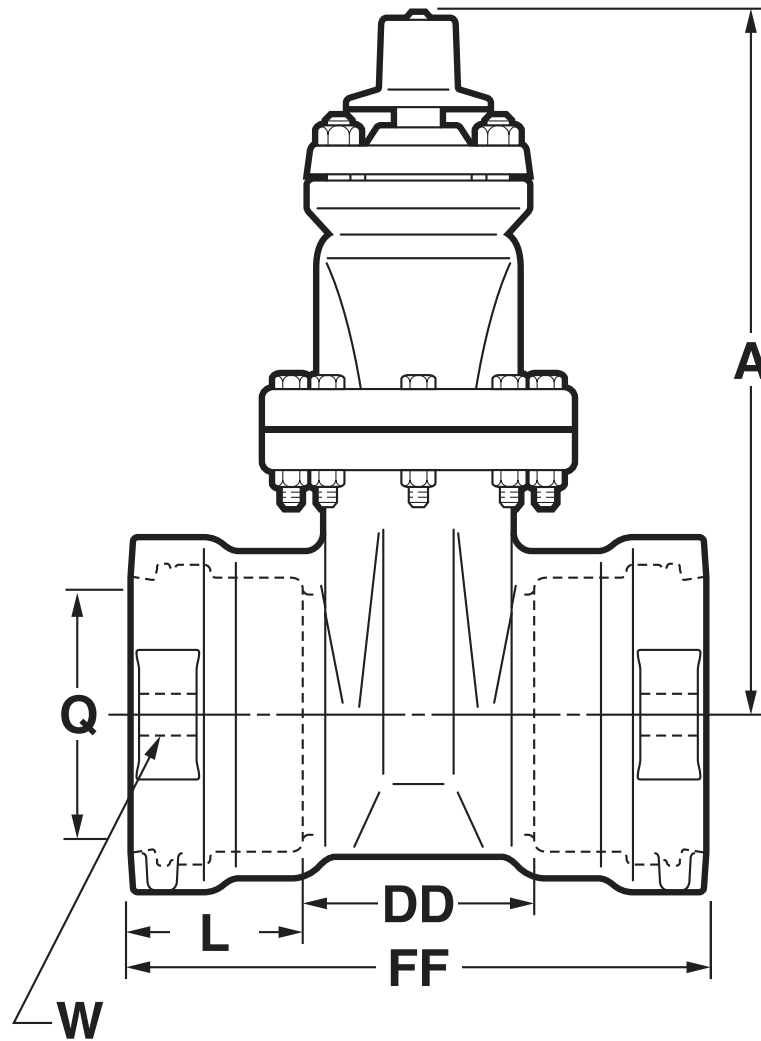

Dimensions

Dimension	Nominal Size				
	4"	6"	8"	10"	12"
A	14.19	18.00	21.50	25.50	28.62
Q (bore)	4.30	6.30	8.30	10.30	12.30
W (distance between strapping lug holes across face of valve ends)	8.62	10.62	13.12	16.38	18.12
FF	12.81	14.96	17.94	18.50	18.70
L	4.12	4.38	5.62	5.62	5.62
DD	4.57	6.2	6.7	7.26	7.46
Turns to open	14	20.5	26.5	33	38.5
Weight*	85	144	233	369	523
Closing Torque (FT-LBS), Non-Geared	75	110	150	185	225
Closing Torque (FT-LBS), Bevel	44	65	88	109	132
Closing Torque (FT-LBS), Spur	41	60	82	101	123

*All dimensions are in inches. All weights are in pounds and are approximate.

**Field Lok is a trademark of U.S. Pipe and Foundry Company, used with permission.

Rev. 4-20

- Catalog number–
A-2361-62 Slip On (less Field Lok gasket) x flange end
- Sizes – 4", 6", 8", 12"
- Meets or exceeds all applicable requirements of ANSI/AWWA C515 Standard, UL 262 Listed, FM 1120/1130 Approved, and certified to ANSI/NSF 61 & 372
- Slip-on ends with Field Lok gaskets are to be used on ductile iron pipe
- Flange end drilling complies with ASME/ANSI B16.1 Class 125**
- Iron body with nominal 10 mils Mueller Pro-Gard® Fusion Bonded Epoxy Coated interior and exterior surfaces
- Epoxy coating meets or exceeds all applicable requirements of ANSI/AWWA C550 Standard
- Iron wedge, symmetrical and fully encapsulated with molded rubber; no exposed iron
- Non-rising stem (NRS)
- Triple O-ring seal (2 above the thrust collar and 1 below)
- 2" square wrench nut – open left or open right
- 350 psig (2400 kPa/24 barg) maximum working pressure; 700 psig (4800 kPa/48 barg) static test pressure
- UL Listed, FM Approved: 350 psig (2400 kPa/24 barg)
- Designed for potable water applications



A-2361-62 shown

Slip-on end on this valve is intended for use with Field Lok†† restrained gaskets.

†Design and dimensions of the joint are manufactured under license of U.S. Pipe and Foundry Company.
††Field Lok is a trademark of U.S. Pipe and Foundry Company, used with permission.

Options

See page 10.54 for more information on Resilient Wedge Gate Valve options

- Position indicators
- Stainless steel stem: Type 304, Type 316
- EPDM Disc and o-rings
- Low zinc, silicon bronze ASTM B98-C66100/H02 stem
- Handwheel

Resilient wedge gate valve parts

Catalog Part Number	Description	Material	Material Standard
G-16	Bonnet Bolts & Nuts	316 Stainless Steel	ASTM F593 (bolt) ASTM F594 (nut)
G-41	Stuffing Box Bolts & Nuts	316 Stainless Steel	ASTM F593 (bolt) ASTM F594 (nut)
G-49	Stem O-rings (3)	Nitrile	ASTM D2000
G-200	Wrench Nut Cap Screw	316 Stainless Steel	ASTM F593
G-201	Stuffing Box O-ring	Nitrile	ASTM D2000
G-202	Wrench Nut	Ductile Iron	ASTMA536 ▼
G-203	Stem	Bronze	ASTM B138
G-204	Hand Wheel (not shown)	Cast Iron +	ASTM A126 CL.B
G-205	Stem Nut	Bronze	ASTM B584
G-206	Guide Cap Bearings	Acetal	-
G-207	Stuffing Box with dirt seal	Ductile Iron Nitrile	ASTMA536 ▼ ASTM D2000
G-208	Anti-friction Washers (2)	Acetal	-
G-209	Wedge, Rubber Encapsulation	Ductile Iron* SBR	AASTMA536 ▼ ASTM D2000
G-210	Bonnet	Ductile Iron	ASTMA536 ▼
G-211	Bonnet O-ring	Nitrile	ASTM D2000
G-212	Body	Ductile Iron	ASTMA536 ▼

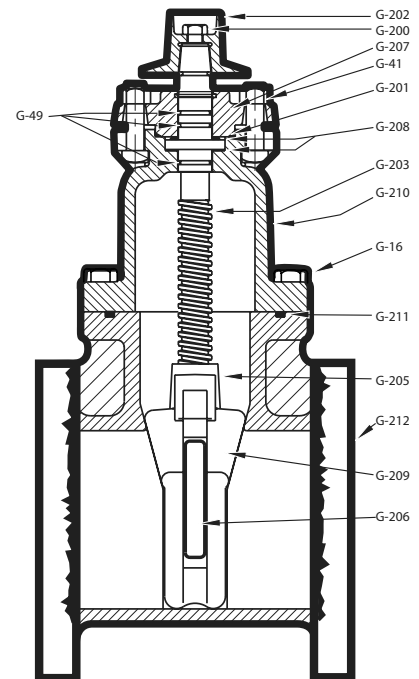

*Fully encapsulated in molded rubber with no iron exposed

▼ Material strength ASTM A536 65-45 minimum

** Per ANSI/AWWA C111 working pressure above 250psi requires the use of a special gasket rated for higher pressure.

+ Manufacturer's option to change material to ductile iron ASTM A536

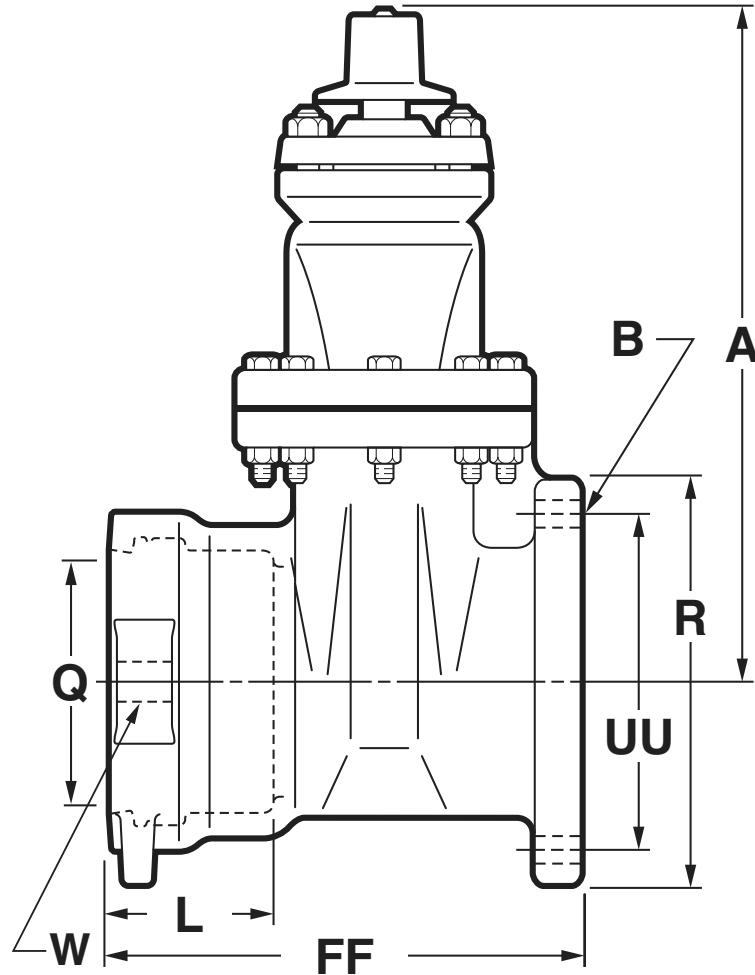

Dimensions

Dimension	Nominal Size				
	4"	6"	8"	10"	12"
A	14.19	18.00	21.50	25.50	28.62
Q (bore)	4.30	6.30	8.30	10.30	12.30
L	4.12	4.38	5.62	5.62	5.62
R	9.00	11.00	13.50	16.00	19.00
UU (bolt circle diameter for FL)	7.50	9.50	11.75	14.25	17.00
B (number and size of holes for FL)	8--.75	8--.88	8--.88	12--1.00	12--1.00
W (distance between strapping lug holes across face of valve ends)	8.62	10.62	13.12	16.38	18.12
FF	10.91	12.73	14.72	15.75	16.35
Turns to open	14	20.5	26.5	33	38.5
Weight*	93	140	241	368	523
Closing Torque (FT-LBS), Non-Geared	75	110	150	185	225
Closing Torque (FT-LBS), Bevel	44	65	88	109	132
Closing Torque (FT-LBS), Spur	41	60	82	101	123

*All dimensions are in inches. All weights are in pounds and are approximate.
 **Field Lok is a trademark of U.S. Pipe and Foundry Company, used with permission.

Rev. 4-20

- Catalog number **A-2361-6** flanged ends
- Sizes – 14", 16", 18", 20", 24", 30", 36", 42", 48", 54"
- Meets or exceeds all applicable requirements of ANSI/AWWA C515 Standard (thru 48"), UL 262 Listed (thru 24"), FM 1120/1130 Approved (thru 24"), and certified to ANSI/NSF 61 & 372
- Flanged ends drilling comply with ASME/ANSI B16.1 Class 125
- Ductile iron body and bonnet with nominal 10 mils Mueller Pro-Gard® Fusion Bonded Epoxy Coated interior and exterior surfaces; 42" – 54" valves coated with Mueller HP Epoxy
- Epoxy coatings meet or exceed all applicable requirements of ANSI/AWWA C550 Standard
- Ductile iron wedge, symmetrical and fully encapsulated with molded rubber; no exposed iron.
- Non-rising stem (NRS)
- Triple O-ring seal (2 above the thrust collar and 1 below)
- 2" square wrench nut - open left or open right (30" - 54" require a Spur Gear or Bevel Gear)
- 250 psig (1725 kPa/17 barg) maximum working pressure; 500 psig (3450 kPa/35 barg) static test pressure
- 14" and 16" sizes – UL Listed, FM Approved: 250 psig (1725 kPa/17 barg)
- 18", 20" and 24" sizes – UL Listed: 175 psig (1200 kPa/12 barg); FM Approved 250 psig (1725 kPa/17 barg)
- Designed for potable water applications



A-2361-6 shown

Options

See page 10.54 for more information on Resilient Wedge Gate Valve options

- Stem Options:
 - 14"-16" low zinc, silicon bronze ASTM B98-C66100/H02
 - Stainless Steel, Type 304, Type 316
 - 18"-54" low zinc, silicon bronze ASTM B763-C99500
 - Stainless Steel Type 304, Type 316
- Position indicators
- Handwheel
- Bypass 16" - 54" (2" on 16"-20"; 2.5" on 24"; 3" on 30"- 36", 4" on 42"-54")
- Spur or bevel geared actuator
- EPDM Disc and o-rings, 14"-16" optional, 18"-54" standard

Resilient wedge gate valve parts

Catalog Part Number	Description	Material	Material Standard
G-16	Bonnet Bolts & Nuts	316 Stainless steel	ASTM F593 (bolt) ASTM F594 (nut)
G-41	Stuffing Box Bolts & Nuts	316 Stainless steel	ASTM F593 (bolt) ASTM F594 (nut)
G-49	Stem O-rings (3)†	Nitrile	ASTM D2000
G-200	Wrench Nut Cap Screw	316 Stainless steel	ASTM F593
G-201	Stuffing Box O-ring†	Nitrile	ASTM D2000
G-202	Wrench Nut	Cast Iron+	ASTM A126 CL.B
G-203	Stem	Bronze	ASTM B138**
G-204	Hand Wheel (not shown)	Cast Iron+	ASTM A126 CL.B
G-205	Stem Nut	Bronze	ASTM B62
G-206	Guide Cap Bearings	Acetal	-
G-207	Stuffing Box	Ductile Iron++	ASTM A536 ▼
G-208	Anti-friction Washers (2)	Acetal	-
G-209	Wedge, Rubber Encapsulation	Ductile Iron* SBR†	ASTM A536 ▼ ASTM D2000
G-210	Bonnet	Ductile Iron	ASTM A536 ▼
G-211	Bonnet O-ring †	Nitrile	ASTM D2000
G-212	Body	Ductile Iron	ASTM A536 ▼

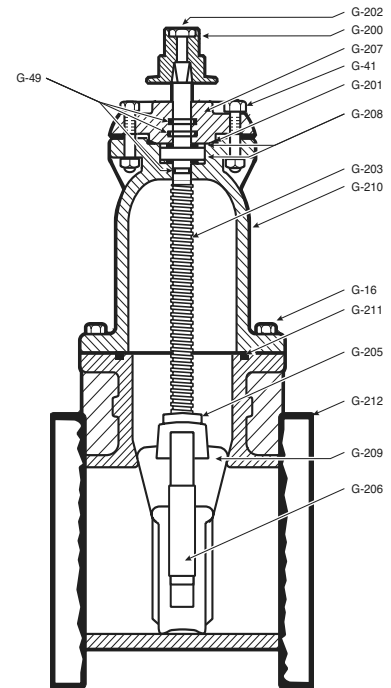

* Fully encapsulated in molded rubber with no iron exposed

† 18"-54" EPDM standard

++ 30"-54" are hot rolled steel ASTM A36

** 18"-54" ASTM B584

+ Manufacturers option to change material to Ductile iron ASTM A536

▼ Material strength ASTM A536 65-45 minimum

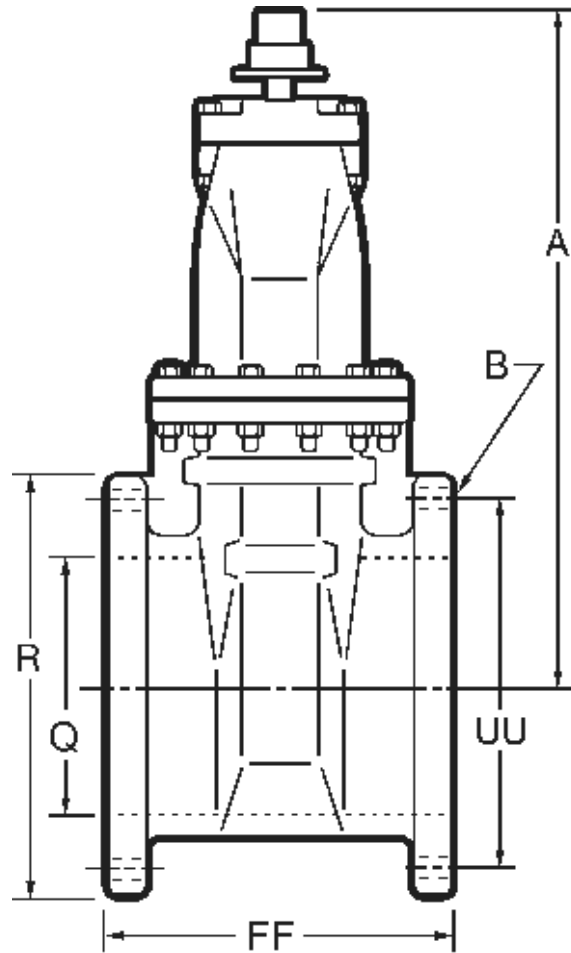

Dimensions

Dimension*	Nominal Size									
	14"	16"	18"	20"	24"	30" †	36" †	42" †	48" †	54" †
A	32.75	37.88	44.19	48.25	53.88	See A for Spur or Bevel Gear				
R	21.00	23.50	25.00	27.50	32.00	38.75	46.00	53.00	59.50	66.34
FF	15.06	16.06	17.00	18.00	20.00	26.00	30.00	38.00	43.00	48.00
Q (bore)	14.38	16.00	18.38	20.38	24.38	30.38	36.38	42.38	48.38	48.38
UU (bolt circle diameter)	18.75	21.25	22.75	25.00	29.50	36.00	42.75	49.50	56.00	62.76
B (number and size of holes)	12--1.125	16--1.125	16--1.25	20--1.25	20--1.38	28--1.38	32--1.63	36--1.63	44--1.63	44--2.00
A - Spur Gear	40.49	43.58	49.41	53.01	59.15	70.81	83.08	97.74	109.70	109.70
A - Bevel Gear**	34.55	37.77	44.50	47.69	54.06	64.93	77.19	90.75	102.61	102.61
Turns to open (without gearing)	43.5	49	57	63	75	-	-	-	-	-
Turns to open (Spur gearing)††	178	201	234	258	308	381	455	524	596	596
Turns to open (Bevel gearing)††	174	196	228	252	300	372	444	524	596	596
Weight*	690	859	1284	1774	2481	6390	8220	13400	19978	20900
Closing Torque (FT-LBS), Non-Geared	225	275	275	300	325	N/A	N/A	N/A	N/A	N/A
Closing Torque (FT-LBS), Bevel	66	81	81	88	96	132	162	206	235	294
Closing Torque (FT-LBS), Spur	61	75	75	81	88	122	149	199	227	284

*All dimensions are in inches. All weights are in pounds and are approximate. Weights for 30"-54" valves are with gearing; for all others without gearing.

**Center line of operating nut to center line of valve.

†Spur or Bevel Gear must be used with 30", 36", 42", 48" & 54" valves.

††Turns shown are for Rotoric gearing supplied by Mueller Co.

Rev. 7-17

- Catalog number
A-2361-16 mechanical joint x flanged ends (with accessories unassembled)
A-2361-19 mechanical joint x flanged ends (less accessories)
- Sizes – 14", 16", 18", 20", 24", 30", 36", 42", 48"
- Meets or exceeds all applicable requirements of ANSI/AWWA C515 Standard, UL 262 Listed, FM 1120/1130 Approved, and certified to ANSI/NSF 61 & 372
- Flanged end drilling complies with ASME/ANSI B16.1 Class 125 and B16.42 class 150
- Mechanical joint end complies with ANSI/AWWA C111 Standard
- Ductile iron body and bonnet with nominal 10 mils Mueller Pro-Gard® Fusion Bonded Epoxy Coated interior and exterior surfaces; 42" and 48" valves coated with Mueller HP Epoxy
- Epoxy coating meets or exceeds all applicable requirements of ANSI/AWWA C550 Standard
- Ductile iron wedge, symmetrical and fully encapsulated with molded rubber; no exposed iron.
- Non-rising stem (NRS)
- Triple O-ring seal (2 above the thrust collar and 1 below)
- 2" square wrench nut - open left or open right (30" - 48" require a Spur Gear or Bevel Gear)
- 250 psig (1725 kPa/17 barg) maximum working pressure; 500 psig (3450 kPa/35 barg) static test pressure
- 14" and 16" sizes – UL Listed, FM Approved: 250 psig (1725 kPa/17 barg)
- 18", 20" and 24" sizes – UL Listed: 175 psig (1200 kPa/12 barg); FM Approved 250 psig (1725 kPa/17 barg)
- Designed for potable water applications



A-2361-19 shown

Options

See page 10.54 for more information on Resilient Wedge Gate Valve options

- Low zinc, silicon bronze ASTM B98-C66100/H02 stem: 14"-16", ASTM B763-C99500: 18"- 48"
- Stainless Steel Stem Type 304, Type 316: 14"- 48"
- Bypass 16" - 48" (2" on 16"-20"; 2.5" on 24"; 3" on 30"- 36", 4" on 42"-48")
- EPDM Disc and o-rings, 14"-16" optional, 18"-48" standard
- Handwheel
- Spur or bevel geared actuator
- Position indicators

Resilient wedge gate valve parts

Catalog Part Number	Description	Material	Material Standard
G-16	Bonnet Bolts & Nuts	316 Stainless steel	ASTM F593 (bolt) ASTM F594 (nut)
G-41	Stuffing Box Bolts & Nuts	316 Stainless steel	ASTM F593 (bolt) ASTM F594 (nut)
G-49	Stem O-rings (3)†	Nitrile	ASTM D2000
G-200	Wrench Nut Cap Screw	316 Stainless steel	ASTM F593
G-201	Stuffing Box O-ring†	Nitrile	ASTM D2000
G-202	Wrench Nut	Cast Iron+	ASTM A126 CL.B
G-203	Stem	Bronze	ASTM B138**
G-204	Hand Wheel (not shown)	Cast Iron+	ASTM A126 CL.B
G-205	Stem Nut	Bronze	ASTM B62
G-206	Guide Cap Bearings	Acetal	-
G-207	Stuffing Box	Ductile Iron++	ASTM A536 ▼
G-208	Anti-friction Washers (2)	Acetal	-
G-209	Wedge, Rubber Encapsulation	Ductile Iron* SBR†	ASTM A536 ▼ ASTM D2000
G-210	Bonnet	Ductile Iron	ASTM A536 ▼
G-211	Bonnet O-ring †	Nitrile	ASTM D2000
G-212	Body	Ductile Iron	ASTM A536 ▼

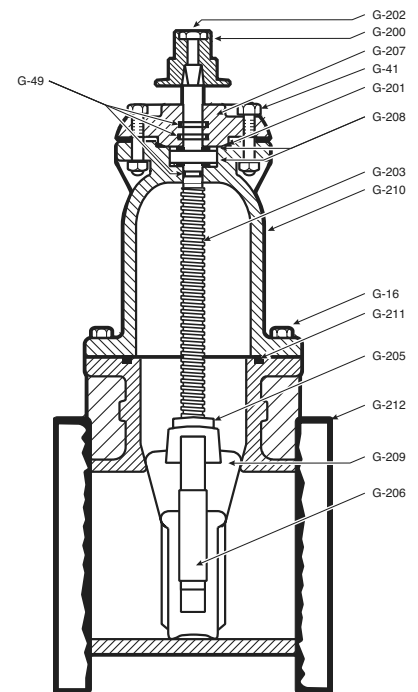

* Fully encapsulated in molded rubber with no iron exposed

**18" - 48" ASTM B584

†18" - 48" EPDM standard

++ 30"-48" are hot rolled steel ASTM A36

+ Manufacturer's option to change material to Ductile iron ASTM A536

▼ Material strength ASTM A536 65-45 minimum

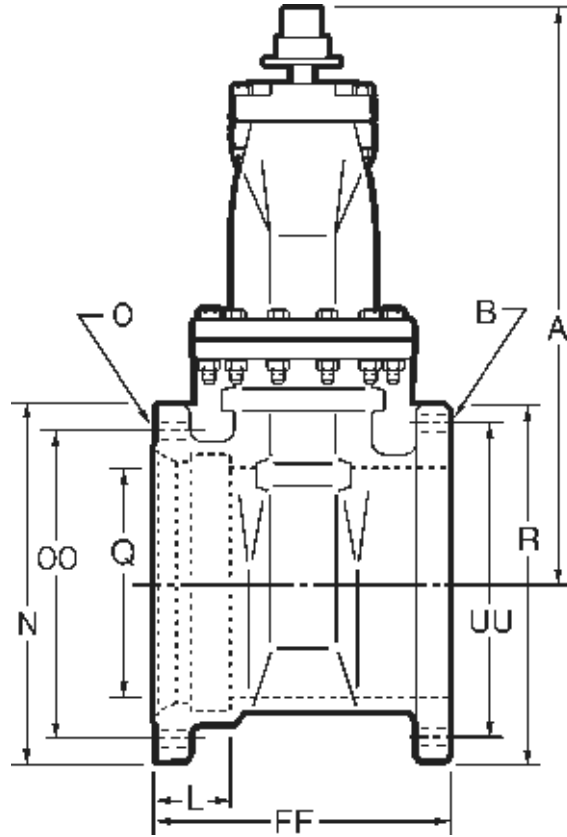

Dimensions

Dimension	Nominal Size									
	14"	16"	18"	20"	24"	30"†	36"†	42"†	48"†	
A	32.75	37.88	44.19	48.25	53.88	See A for Spur or Bevel Gear				
L	3.50	3.50	3.50	3.50	3.50	4.00	4.00	4.00	4.00	
N	20.66	22.66	24.88	27.25	31.88	39.53	46.41	53.53	60.41	
O (number and size of holes for MJ)	10--.88	12--.88	12--.88	14--.88	16--.88	20--1.125	24--1.125	28--1.38	32--1.38	
Q (bore)	14.38	16.00	18.38	20.38	24.38	30.38	36.38	42.38	48.38	
OO (bolt circle diameter for MJ)	18.75	21.00	23.25	25.50	30.00	36.88	43.75	50.62	57.50	
R	21.00	23.50	25.00	27.50	32.00	38.75	46.00	53.00	59.50	
UU (bolt circle diameter)	18.75	21.25	22.75	25.00	29.50	36.00	42.75	49.50	56.00	
FF	17.41	17.91	19	19.75	21.75	29.75	33.75	40.19	43.86	
B (number and size of holes for FL)	12--1.12	16--1.12	16--1.12	20--1.25	20--1.38	28--1.38	32--1.63	36--1.63	44--1.63	
A - Spur Gear	40.49	43.58	49.41	53.01	59.15	70.81	83.08	97.74	109.70	
A - Bevel Gear**	34.55	37.77	44.50	47.69	54.06	64.93	77.19	90.75	102.61	
Turns to open (without gearing)	43.5	49	57	63	75	-	-	-	-	
Turns to open (Spur gearing)	178	201	234	258	308	381	455	524	596	
Turns to open (Bevel gearing)	174††	196††	228††	252††	300††	372††	444††	524††	596††	
Weight*	693	850	1279	1795	2459	6457	8412	13083	19841	
Closing Torque (FT-LBS), Non-Geared	225	275	275	300	325	N/A	N/A	N/A	N/A	
Closing Torque (FT-LBS), Bevel	66	81	81	88	96	132	162	206	235	
Closing Torque (FT-LBS), Spur	61	75	75	81	88	122	149	199	227	

*All dimensions are in inches. All weights are in pounds and are approximate. Weights for 30"-48" valves are with gearing; for all others without gearing.

**Center line of operating nut to center line of valve.

†Spur or Bevel Gear must be used with 30", 36", 42", 48" valves.

††Turns shown for Bevel gearing. Valves with Bevel gearing: All Sizes - 4:1 ratio.

Rev. 7-17

- Catalog number
A-2361-20 Mechanical joint ends (with accessories unassembled)
A-2361-23 Mechanical joint ends (less accessories)
- Sizes – 14", 16", 18", 20", 24", 30", 36", 42", 48"
- Meets or exceeds all applicable requirements of ANSI/AWWA C515 Standard, UL 262 Listed, FM 1120/1130 Approved, and certified to ANSI/NSF 61 & 372
- Mechanical joint ends comply with ANSI/AWWA C111 Standard.
- Ductile Iron body and bonnet with nominal 10 mils Mueller Pro-Gard® Fusion Bonded Epoxy Coated interior and exterior surfaces; 42" and 48" valves coated with Mueller HP Epoxy
- Epoxy coating meets or exceeds all applicable requirements of ANSI/AWWA C550 Standard
- Ductile Iron wedge, symmetrical and fully encapsulated with molded rubber; no exposed iron.
- Non-rising stem (NRS)
- Triple O-ring seal (2 above the thrust collar and 1 below)
- 2" square wrench nut - open left or open right (30" - 48" require a Spur Gear or Bevel Gear)
- 250 psig (1725 kPa/17 barg) maximum working pressure; 500 psig (3450 kPa/35 barg) static test pressure
- 14" and 16" sizes – UL Listed, FM Approved: 250 psig (1725 kPa/17 barg)
- 18", 20" and 24" sizes – UL Listed: 175 psig (1200 kPa/12 barg); FM Approved 250 psig (1725 kPa/17 barg)
- Designed for potable water applications



A-2361-23 shown

Options

See page 10.54 for more information on Resilient Wedge Gate Valve options

- Position indicators
- Low zinc, silicon bronze ASTM B98-C66100/H02 stem: 14"-16", ASTM B763-C99500: 18"- 48"
- Bypass 16" - 48" (2" on 16"-20"; 2.5" on 24"; 3" on 30"- 36", 4" on 42"-48")
- EPDM Disc and o-rings, 14"-16" optional, 18"-48" standard
- Handwheel
- Stainless Steel Stem Type 304, Type 316
- Spur or bevel geared actuator

Resilient wedge gate valve parts

Catalog Part Number	Description	Material	Material Standard
G-16	Bonnet Bolts & Nuts	316 Stainless steel	ASTM F593 (bolt) ASTM F594 (nut)
G-41	Stuffing Box Bolts & Nuts	316 Stainless steel	ASTM F593 (bolt) ASTM F594 (nut)
G-49	Stem O-rings (3)†	Nitrile	ASTM D2000
G-200	Wrench Nut Cap Screw	316 Stainless steel	ASTM F593
G-201	Stuffing Box O-ring†	Nitrile	ASTM D2000
G-202	Wrench Nut	Cast Iron+	ASTM A126 CL.B
G-203	Stem	Bronze	ASTM B138**
G-204	Hand Wheel (not shown)	Cast Iron+	ASTM A126 CL.B
G-205	Stem Nut	Bronze	ASTM B62
G-206	Guide Cap Bearings	Acetal	-
G-207	Stuffing Box	Ductile Iron++	ASTM A536 ▼
G-208	Anti-friction Washers (2)	Acetal	-
G-209	Wedge, Rubber Encapsulation	Ductile Iron* SBR†	ASTM A536 ▼ ASTM D2000
G-210	Bonnet	Ductile Iron	ASTM A536 ▼
G-211	Bonnet O-ring †	Nitrile	ASTM D2000
G-212	Body	Ductile Iron	ASTM A536 ▼

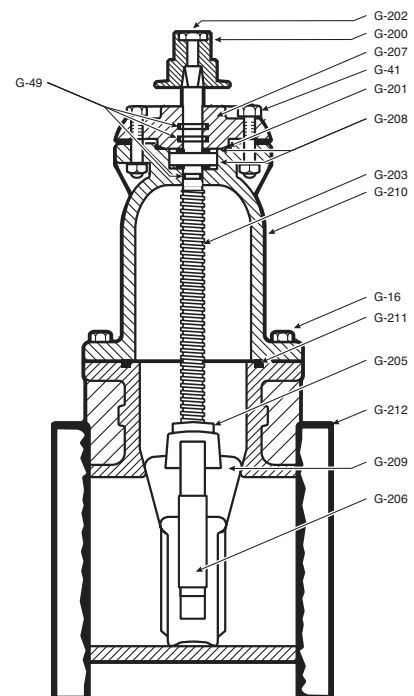

* Fully encapsulated in molded rubber with no iron exposed

**18" - 48" ASTM B584

†18" - 48" EPDM standard

++30"-48" are hot rolled steel ASTM A36

+ Manufacturers option to change material to Ductile iron ASTM A536

▼ Material strength ASTM A536 65-45 minimum

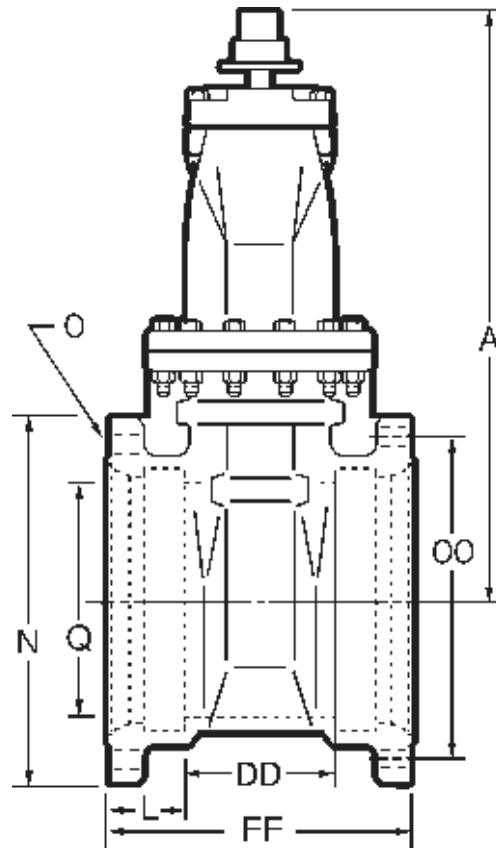

Dimensions

Dimension	Nominal Size								
	14"	16"	18"	20"	24"	30"†	36"†	42"†	48"†
A	32.75	37.88	44.19	48.25	53.88	See A for Spur or Bevel Gear			
L	3.50	3.50	3.50	3.50	3.50	4.00	4.00	4.00	4.00
N	20.62	22.56	24.88	27.01	31.88	39.53	46.41	53.53	60.41
O (number and size of holes for MJ)	10--.88	12--.88	12--.88	14--.88	16--.88	20--1.125	24--1.125	28--1.38	32--1.38
Q (bore)	14.38	16.00	18.38	20.38	24.38	30.38	36.38	42.38	48.38
OO (bolt circle diameter for MJ)	18.75	21.00	23.25	25.50	30.00	36.88	43.75	50.62	57.50
R	21.00	23.50	25.00	27.50	32.00	38.75	46.00	53.00	59.50
UU (bolt circle diameter)	18.75	21.25	22.75	25.00	29.50	36.00	42.75	49.50	56.00
FF	19.75	19.75	21.00	21.50	23.50	33.50	37.50	42.37	44.72
B (number and size of holes for FL)	12--1.12	16--1.12	16--1.12	20--1.25	20--1.38	28--1.38	32--1.63	36--1.63	44--1.63
A - Spur Gear	40.49	43.58	49.41	53.01	59.15	70.81	83.08	97.74	109.70
A - Bevel Gear**	34.55	37.77	44.50	47.69	54.06	64.93	77.19	90.75	102.61
DD	12.36	12.55	13.90	14.13	16.06	25.56	29.34	34.58	36.80
Turns to open (without gearing)	43.5	49	57	63	75	-	-	-	-
Turns to open (Spur gearing)	178	201	234	258	308	381	455	524	596
Turns to open (Bevel gearing)	174††	196††	228††	252††	300††	372††	444††	524††	596††
Weight*	695	846	1274	1820	2438	6523	8400	13300	19700
Closing Torque (FT-LBS), Non-Geared	225	275	275	300	325	N/A	N/A	N/A	N/A
Closing Torque (FT-LBS), Bevel	66	81	81	88	96	132	162	206	235
Closing Torque (FT-LBS), Spur	61	75	75	81	88	122	149	199	227

*All dimensions are in inches. All weights are in pounds and are approximate. Weights for 30"-48" valves are with gearing; for all others without gearing.

**Center line of operating nut to center line of valve.

†Spur or Bevel Gear must be used with 30", 36", 42", 48" valves.

††Turns shown for Bevel gearing. Valves with Bevel gearing: All Sizes - 4:1 ratio.

Rev. 7-17

- Catalog number
A-2361-38 Slip-on† ends with gasket
A-2361-40 Slip-on† ends less gasket
- Sizes – 14", 16"
- Meets or exceeds all applicable requirements of ANSI/AWWA C515 Standard, UL 262 Listed, FM 1120/1130 Approved, and certified to ANSI/NSF 61 & 372
- Slip-on ends fit plain end of classes 50 and 100 cast iron; ductile iron and AWWA C905 cast iron O.D. PVC
- Ductile iron body with nominal 10 mils Mueller Pro-Gard® Fusion Bonded Epoxy Coated interior and exterior surfaces
- Epoxy coating meets or exceeds all applicable requirements of ANSI/AWWA C550 Standard
- Ductile iron wedge, symmetrical and fully encapsulated with molded rubber; no exposed iron
- Non-rising stem (NRS)
- Triple O-ring seal (2 above the thrust collar and 1 below)
- 2" square wrench nut - open left or open right
- 250 psig (1725 kPa/17 barg) maximum working pressure; 500 psig (3450 kPa/35 barg) static test pressure
- UL Listed, FM Approved – 250 psig (1725 kPa/17 barg)
- Valves are designed for potable water applications



A-2361-40 shown

†Design and dimensions of the joint are manufactured under license of U.S. Pipe and Foundry Company.

Options

See page 10.54 for more information on Resilient Wedge Gate Valve options

- Position indicators
- Spur or bevel geared actuator
- EPDM Disc and O-rings
- Handwheel
- Stainless Steel stem: Type 304, Type 316
- Low zinc, silicon bronze ASTM B98-C66100/H02 stem

Resilient wedge gate valve parts

Catalog Part Number	Description	Material	Material Standard
G-16	Bonnet Bolts & Nuts	316 Stainless Steel	ASTM F593 (bolt) ASTM F594 (nut)
G-41	Stuffing Box Bolts & Nuts	316 Stainless Steel	ASTM F593 (bolt) ASTM F594 (nut)
G-49	Stem O-rings (3)	Nitrile	ASTM D2000
G-200	Wrench Nut Cap Screw	316 Stainless Steel	ASTM F593
G-201	Stuffing Box O-ring	Nitrile	ASTM D2000
G-202	Wrench Nut	Cast Iron+	ASTM A126 CL.B
G-203	Stem	Bronze	ASTM B138
G-204	Hand Wheel (not shown)	Cast Iron+	ASTM A126 CL.B
G-205	Stem Nut	Bronze	ASTM B62
G-206	Guide Cap Bearings	Acetal	-
G-207	Stuffing Box	Ductile Iron	ASTM A536 ▼
G-208	Anti-friction Washers (2)	Acetal	-
G-209	Wedge, Rubber Encapsulation	Ductile Iron SBR*	ASTM A536 ▼ ASTM D2000
G-210	Bonnet	Ductile Iron	ASTM A536 ▼
G-211	Bonnet O-ring	Nitrile	ASTM D2000
G-212	Body	Ductile Iron	ASTM A536 ▼

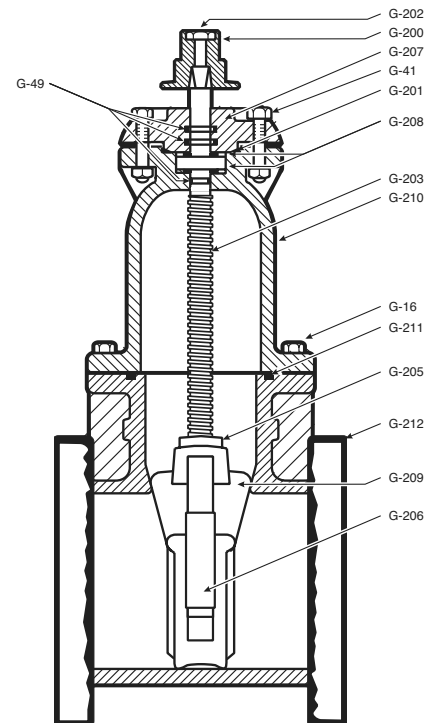

* Fully encapsulated in molded rubber with no iron exposed

+ Manufacturers option to change material to Ductile iron ASTM A536

▼ Material strength ASTM A536 65-45 minimum

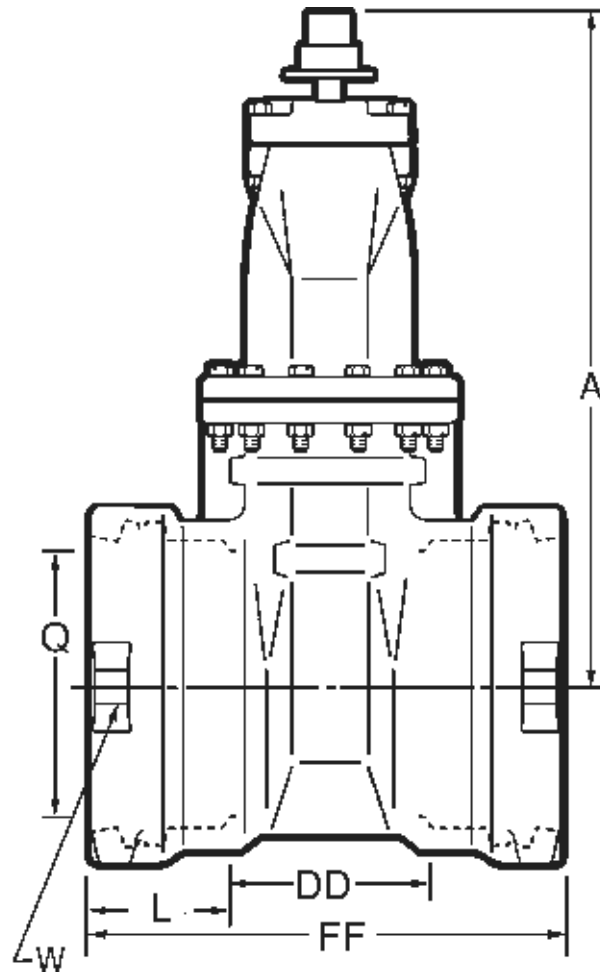

Dimensions

Dimension	Nominal Size	
	14"	16"
A	32.75	37.88
Q (bore)	14.38	16.00
W (distance between strapping lug holes across face of valve ends)	22.50	23.12
FF	24.42	25.32
L	6.00	6.00
DD	12.42	13.32
A - Spur Gear	40.49	43.58
A - Bevel Gear**	34.55	37.77
Turns to open (without gearing)	43.5	49
Turns to open (Spur gearing)	178	201
Turns to open (Bevel gearing)	174	196
Weight*	705	885
Closing Torque (FT-LBS), Non-Geared	225	275
Closing Torque (FT-LBS), Bevel	66	81
Closing Torque (FT-LBS), Spur	61	75

*All dimensions are in inches. All weights are in pounds and are approximate.

**Center line of operating nut to center line of valve.

Rev. 7-17

- Catalog number–
A-2361-41 Slip-on† end (with gasket) x flange end
A-2361-43 Slip-on† end (less gasket) x flange end
- Sizes – 14", 16"
- Meets or exceeds all applicable requirements of ANSI/AWWA C515 Standard, UL 262 Listed, FM 1120/1130 Approved, and certified to ANSI/NSF 61 & 372
- Slip-on ends fit plain end of classes 50 and 100 cast iron; ductile iron and AWWA C905 cast iron O.D. PVC
- Flanged end drilling complies with ASME/ANSI B16.1 class 125 and B16.42 class 150
- Ductile iron body and bonnet with nominal 10 mils Mueller Pro-Gard® Fusion Bonded Epoxy Coated interior and exterior surfaces
- Epoxy coating meets or exceeds all applicable requirements of ANSI/AWWA C550 Standard
- Ductile iron wedge, symmetrical and fully encapsulated with molded rubber; no exposed iron
- Non-rising stem (NRS)
- Triple O-ring seal (2 above the thrust collar and 1 below)
- 2" square wrench nut - open left or open right
- 250 psig (1725 kPa/17 barg) maximum working pressure; 500 psig (3450 kPa/35 barg) static test pressure
- UL Listed, FM Approved – 250 psig (1725 kPa/17 barg)
- Designed for potable water applications



A-2361-43 shown

†Design and dimensions of the joint are manufactured under license of U.S. Pipe and Foundry Company.

Options

See page 10.54 for more information on Resilient Wedge Gate Valve options

- Position indicators
- Low zinc, silicon bronze ASTM B98-C66100/H02 stem
- Spur or bevel geared actuator
- Handwheel
- EPDM disc and o-rings
- Stainless Steel stem: Type 304, Type 316

Resilient wedge gate valve parts

Catalog Part Number	Description	Material	Material Standard
G-16	Bonnet Bolts & Nuts	316 Stainless Steel	ASTM F593 (bolt) ASTM F594 (nut)
G-41	Stuffing Box Bolts & Nuts	316 Stainless Steel	ASTM F593 (bolt) ASTM F594 (nut)
G-49	Stem O-rings (3)	Nitrile	ASTM D2000
G-200	Wrench Nut Cap Screw	316 Stainless Steel	ASTM F593
G-201	Stuffing Box O-ring	Nitrile	ASTM D2000
G-202	Wrench Nut	Cast Iron+	ASTM A126 CL.B
G-203	Stem	Bronze	ASTM B138
G-204	Hand Wheel (not shown)	Cast Iron+	ASTM A126 CL.B
G-205	Stem Nut	Bronze	ASTM B62
G-206	Guide Cap Bearings	Acetal	-
G-207	Stuffing Box	Ductile Iron	ASTM A536 ▼
G-208	Anti-friction Washers (2)	Acetal	-
G-209	Wedge, Rubber Encapsulation	Ductile Iron SBR	ASTM A536 ▼ ASTM D2000
G-210	Bonnet	Ductile Iron	ASTM A536 ▼
G-211	Bonnet O-ring	Nitrile	ASTM D2000
G-212	Body	Ductile Iron	ASTM A536 ▼

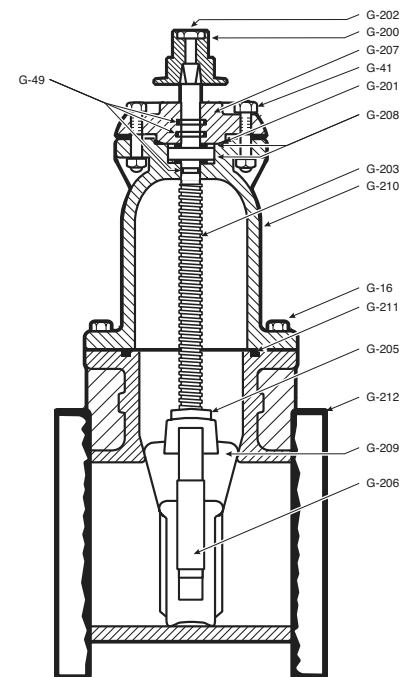

* Fully encapsulated in molded rubber with no iron exposed
 + Manufacturer's option to change material to Ductile iron ASTM A536
 ▼ Material strength ASTM A536 65-45 minimum

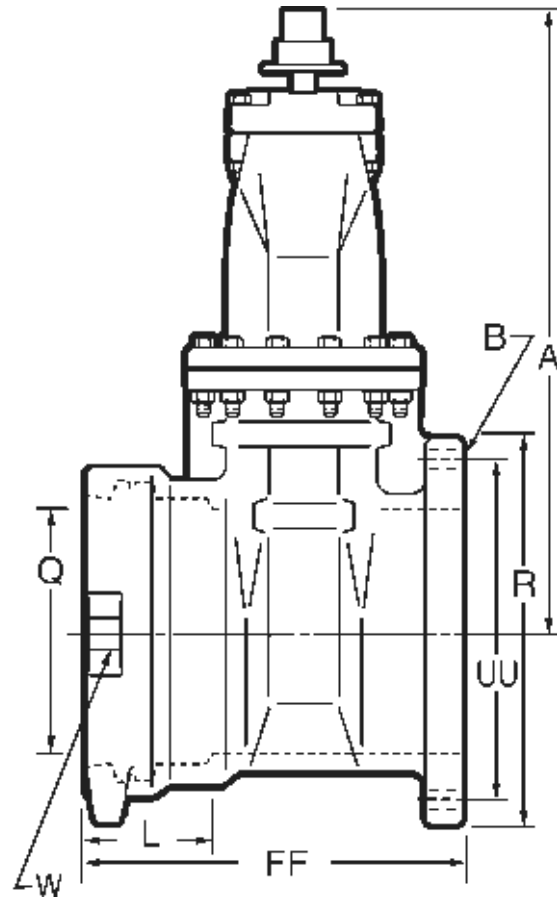

Dimensions

Dimension	Nominal Size	
	14"	16"
A	32.75	37.88
Q (bore)	14.38	16.00
W (distance between strapping lug holes across face of valve ends)	22.50	23.12
L	6.00	6.00
R	21.00	23.50
UU	18.75	21.25
B (number and size of holes)	12--1.12	16--1.12
FF	19.74	20.69
A - Spur Gear	40.49	43.58
A - Bevel Gear**	34.55	37.77
Turns to open (without gearing)	43.5	49
Turns to open (Spur gearing)	178	201
Turns to open (Bevel gearing)	198	221
Weight*	689	873
Closing Torque (FT-LBS), Non-Geared	225	275
Closing Torque (FT-LBS), Bevel	66	81
Closing Torque (FT-LBS), Spur	61	75

*All dimensions are in inches. All weights are in pounds and are approximate.

**Center line of operating nut to center line of valve.

Rev. 7-17

- Catalog number
A-2361-76 Aqua-Grip ends x flanged ends for DIPS pipe in sizes 4", 6", 8", 10", 12"
A-2361-86 Aqua-Grip ends x flanged ends for IPS pipe in sizes 4", 6", 8"
- Meets or exceeds all applicable requirements of ANSI/AWWA C515 Standard, UL 262 Listed, FM 1120/1130 Approved, and certified to ANSI/NSF 61 & 372
- Flanged end drilling complies with ASME/ANSI B16.1 class 125 and B16.42 class 125
- Ductile iron body and bonnet with nominal 10 mils Mueller Pro-Gard® Fusion Bonded Epoxy Coated interior and exterior surfaces
- Epoxy coating meets or exceeds all applicable requirements of ANSI/AWWA C550 Standard
- Iron wedge, symmetrical and fully encapsulated with molded rubber; no exposed iron
- Non-rising stem (NRS)
- Triple O-ring seal (2 above the thrust collar and 1 below)
- 2" square wrench nut - open left or open right
- 250 psig (1725 kPa/17 barg) maximum working pressure; 500 psig (3450 kPa/35 barg) static test pressure
- UL Listed, FM Approved – 200 psig (1375 kPa/14 barg)
- Designed for potable water applications



A-2361-76 shown

Options

See page 10.54 for more information on Resilient Wedge Gate Valve options

- Position indicators
- Stainless steel stem: Type 304, Type 316
- EPDM Disc and o-ring
- Low zinc, silicon bronze ASTM B98-C66100/H02 stem
- Handwheel

Resilient wedge gate valve parts

Catalog Part Number	Description	Material	Material Standard
G-16	Bonnet Bolts & Nuts	316 Stainless Steel	ASTM F593 (bolt) ASTM F594 (nut)
G-41	Stuffing Box Bolts & Nuts	316 Stainless Steel	ASTM F593 (bolt) ASTM F594 (nut)
G-49	Stem O-rings (3)	Nitrile	ASTM D2000
G-200	Wrench Nut Cap Screw	316 Stainless Steel	ASTM F593
G-201	Stuffing Box O-ring	Nitrile	ASTM D2000
G-202	Wrench Nut	Ductile iron	ASTM A536 ▼
G-203	Stem	Bronze	ASTM B138
G-204	Hand Wheel (not shown)	Cast Iron +	ASTM A126 CL.B
G-205	Stem Nut	Bronze	ASTM B584
G-206	Guide Cap Bearings	Acetal	-
G-207	Stuffing Box with dirt seal	Ductile Iron Nitrile	ASTM A536 ▼ ASTM D2000
G-208	Anti-friction Washers (2)	Acetal	-
G-209	Wedge, Rubber Encapsulation	Ductile Iron * SBR	ASTM A536 ▼ ASTM D2000
G-210	Bonnet	Ductile Iron	ASTM A536 ▼
G-211	Bonnet O-ring	Nitrile	ASTM D2000
G-212	Body	Ductile Iron	ASTM A536 ▼
G-213	Double O-ring**	EPDM	ASTM D2000
G-214	Intermediate ring**	Ductile Iron	ASTM A536 ▼
G-215	Gripper ring**	Ductile Iron	ASTM A536 ▼
G-216	End ring**	Ductile Iron	ASTM A536 ▼
G-217	Breakaway Nut with washer***	Steel	ASTM A108 ▼
G-218	T-head Bolt***	Steel	ASTM A242

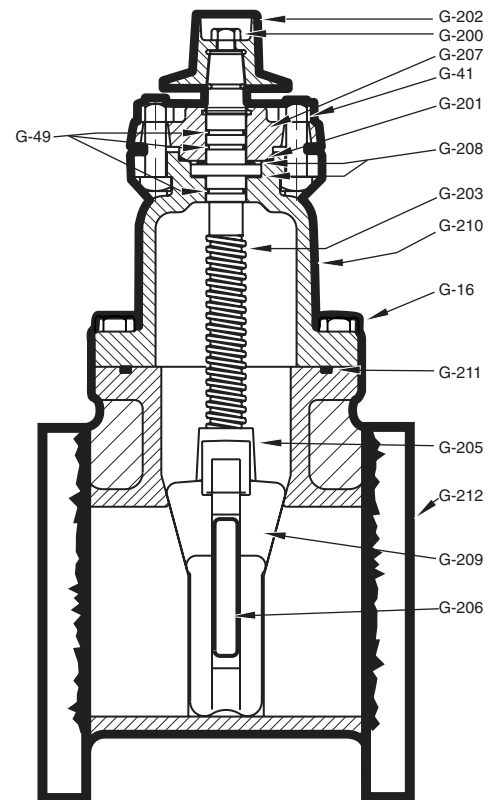

*Fully encapsulated in molded rubber with no iron exposed.

**Parts for Aqua-Grip connection not shown – one required for each Aqua-Grip connection.

***Not shown. See dimension drawing on next page for number require for each size Aqua-Grip connection.

+ Manufacturers option to change material to Ductile iron ASTM A536

▼ Material strength ASTM A536 65-45 minimum

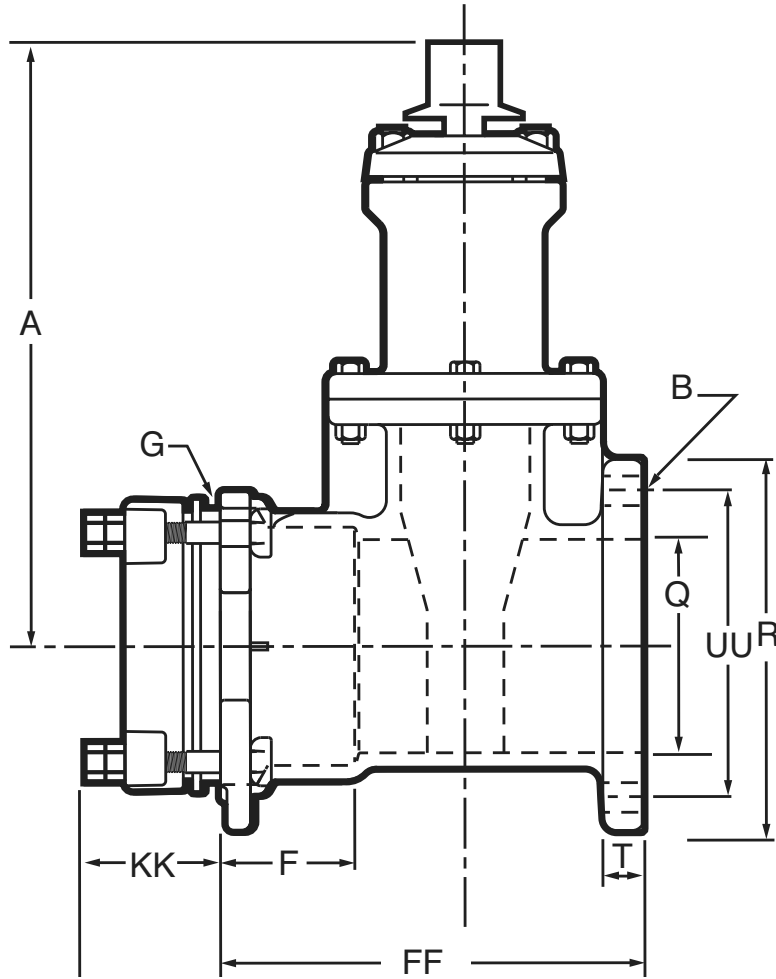

Dimensions

Dimension	Nominal Size				
	4"	6"	8"	10"	12"
A	14.19	18.00	21.50	25.50	28.62
B (number and size of holes for FL)	8--.75	8--.88	8--.88	12--1.00	12--1.00
F	3.70	3.70	3.70	3.89	3.89
G (number and size of holes for Aqua-Grip)	4--.88	4--.88	6--.88	8--.88	8--.88
T	.87	1.05	1.05	1.06	1.12
R	9.00	11.00	13.50	16.00	9.00
Q (bore)	4.30	6.30	2.30	10.30	12.30
FF	10.93	12.9	14.28	15.58	16.51
KK	2.75	3.75	3.75	3.75	3.75
UU (bolt circle diameter for FL)	7.50	9.50	11.75	14.25	17.00
Turns to open	14	20.5	26.5	33.0	38.5
Weight*	98	153	246	351	481
Closing Torque (FT-LBS), Non-Geared	75	110	150	185	225
Closing Torque (FT-LBS), Bevel	44	65	88	109	132
Closing Torque (FT-LBS), Spur	41	60	82	101	123

*All dimensions are in inches. All weights are in approximate pounds.

Rev. 7-17

- Catalog number–
A-2361-77 Aqua-Grip ends x Aqua-Grip ends for DIPS pipe in sizes 4", 6", 8", 10", 12"
A-2361-87 Aqua-Grip ends x Aqua-Grip ends for IPS pipe in sizes 4", 6", 8"
- Meets or exceeds all applicable requirements of ANSI/AWWA C515 Standard, UL 262 Listed, FM 1120/1130 Approved, and certified to ANSI/NSF 61 & 372
- Ductile Iron body and bonnet with nominal 10 mils Mueller Pro-Gard® Fusion Bonded Epoxy Coated interior and exterior surfaces
- Epoxy coating meets or exceeds all applicable requirements of ANSI/AWWA C550 Standard
- Iron wedge, symmetrical and fully encapsulated with molded rubber; no exposed iron
- Non-rising stem (NRS)
- Triple O-ring seal (2 above the thrust collar and 1 below)
- 2" square wrench nut - open left or open right
- 250 psig (1725 kPa/17 barg) maximum working pressure; 500 psig (3450 kPa/35 barg) static test pressure
- UL Listed, FM Approved – 200 psig (1375 kPa/14 barg)
- Designed for potable water applications



A-2361-77 shown

Options

See page 10.54 for more information on Resilient Wedge Gate Valve options

- Position indicators
- Low zinc, silicon bronze ASTM B98-C66100/H02 stem
- Stainless steel stem: Type 304, Type 316
- Handwheel
- EPDM Disc and o-ring

Resilient wedge gate valve parts

Catalog Part Number	Description	Material	Material Standard
G-16	Bonnet Bolts & Nuts	316 Stainless Steel	ASTM F593 (bolt) ASTM F594 (nut)
G-41	Stuffing Box Bolts & Nuts	316 Stainless Steel	ASTM F593 (bolt) ASTM F594 (nut)
G-49	Stem O-rings (3)	Nitrile	ASTM D2000
G-200	Wrench Nut Cap Screw	316 Stainless Steel	ASTM F593
G-201	Stuffing Box O-ring	Nitrile	ASTM D2000
G-202	Wrench Nut	Ductile iron	ASTM A536 ▼
G-203	Stem	Bronze	ASTM B138
G-204	Hand Wheel (not shown)	Cast Iron +	ASTM A126 CL.B
G-205	Stem Nut	Bronze	ASTM B584
G-206	Guide Cap Bearings	Acetal	-
G-207	Stuffing Box with dirt seal	Ductile Iron Nitrile	ASTM A536 ▼ ASTM D2000
G-208	Anti-friction Washers (2)	Acetal	-
G-209	Wedge, Rubber Encapsulation	Ductile iron SBR	ASTM A536 ▼ ASTM D2000
G-210	Bonnet	Ductile Iron	ASTM A536 ▼
G-211	Bonnet O-ring	Nitrile	ASTM D2000
G-212	Body	Ductile Iron	ASTM A536 ▼
G-213	Double O-ring**	EPDM	ASTM D2000
G-214	Intermediate ring**	Ductile Iron	ASTM A536 ▼
G-215	Gripper ring**	Ductile Iron	ASTM A536 ▼
G-216	End ring**	Ductile Iron	ASTM A536 ▼
G-217	Breakaway Nut with washer***	Steel	ASTM A108
G-218	T-head Bolt***	Steel	ASTM A242

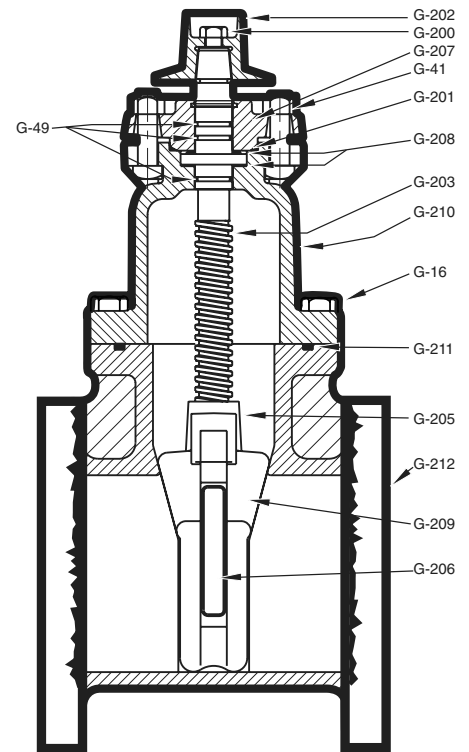

*Fully encapsulated in molded rubber with no iron exposed.

**Parts for Aqua-Grip connection not shown – one required for each Aqua-Grip connection.

***Not shown. See dimension drawing on next page for number require for each size Aqua-Grip connection.

+ Manufacturers option to change material to Ductile iron ASTM A536

▼ Material strength ASTM A536 65-45 minimum

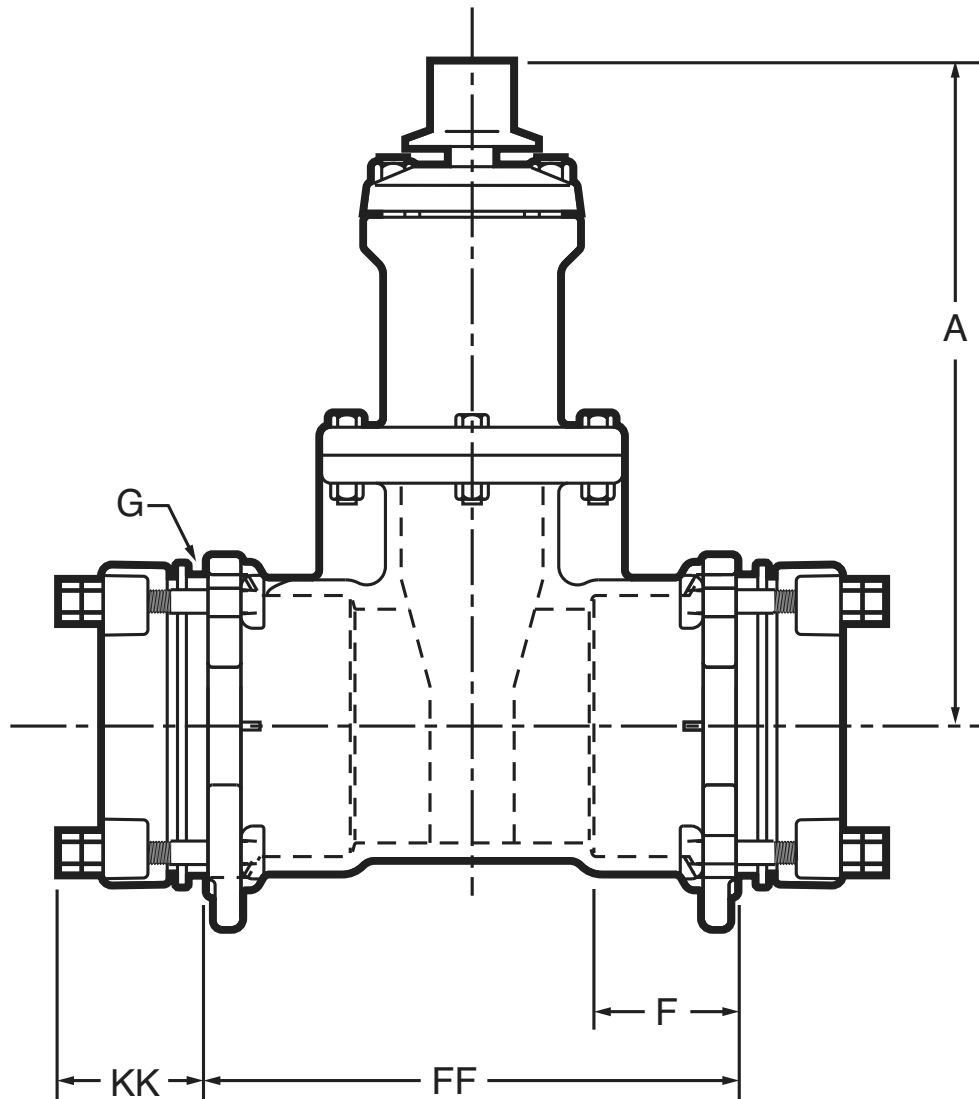

Dimensions

Dimension	Nominal Size				
	4"	6"	8"	10"	12"
A	14.19	18.00	21.50	25.50	28.62
FF	12.68	15.12	16.94	18.06	18.90
G (number and size of holes for Aqua-Grip)	4--.88	4--.88	6--.88	8--.88	8--.88
F	3.70	3.70	3.70	3.75	3.75
KK	2.75	3.75	3.75	3.75	3.75
Turns to open	14	20.5	26.5	33.0	38.5
Weight*	113	168	277	385	516
Closing Torque (FT-LBS), Non-Geared	75	110	150	185	225
Closing Torque (FT-LBS), Bevel	44	65	88	109	132
Closing Torque (FT-LBS), Spur	41	60	82	101	123

*All dimensions are in inches. All weights are in approximate pounds.

Rev. 7-17

- Catalog number
A-2361-78 Aqua-Grip ends x mechanical joint for DIPS pipe in sizes 4", 6", 8", 10", 12"
A-2361-88 Aqua-Grip ends x mechanical joint for IPS pipe in sizes 4", 6", 8"
- Meets or exceeds all applicable requirements of ANSI/AWWA C515 Standard, UL 262 Listed, FM 1120/1130 Approved, and certified to ANSI/NSF 61 & 372
- Ductile Iron body and bonnet with nominal 10 mils Mueller Pro-Gard® Fusion Bonded Epoxy Coated interior and exterior surfaces.
- Epoxy coating meets or exceeds all applicable requirements of ANSI/AWWA C550 Standard
- Iron wedge, symmetrical and fully encapsulated with molded rubber; no exposed iron
- Non-rising stem (NRS)
- Triple O-ring seal (2 above the thrust collar and 1 below)
- 2" square wrench nut - open left or open right
- 250 psig (1725 kPa/17 barg) maximum working pressure; 500 psig (3450 kPa/35 barg) static test pressure
- UL Listed, FM Approved – 200 psig (1375 kPa/14 barg)
- Designed for potable water applications



A-2361-78 shown

Options

See page 10.54 for more information on Resilient Wedge Gate Valve options

- Position indicators
- Low zinc, silicon bronze ASTM B98-C66100/H02 stem
- Stainless steel stem: Type 304, Type 316
- Handwheel
- EPDM Disc and o-ring

Resilient wedge gate valve parts

Catalog Part Number	Description	Material	Material Standard
G-16	Bonnet Bolts & Nuts	316 Stainless Steel	ASTM F593 (bolt) ASTM F594 (nut)
G-41	Stuffing Box Bolts & Nuts	316 Stainless Steel	ASTM F593 (bolt) ASTM F594 (nut)
G-49	Stem O-rings (3)	Nitrile	ASTM D2000
G-200	Wrench Nut Cap Screw	316 Stainless Steel	ASTM F593
G-201	Stuffing Box O-ring	Nitrile	ASTM D2000
G-202	Wrench Nut	Ductile iron	ASTM A536 ▼
G-203	Stem	Bronze	ASTM B138
G-204	Hand Wheel (not shown)	Cast Iron +	ASTM A126 CL.B
G-205	Stem Nut	Bronze	ASTM B584
G-206	Guide Cap Bearings	Acetal	-
G-207	Stuffing Box with dirt seal	Ductile Iron Nitrile	ASTM A536 ▼ ASTM D2000
G-208	Anti-friction Washers (2)	Acetal	-
G-209	Wedge, Rubber Encapsulation	Ductile Iron* SBR	ASTM A536 ▼ ASTM D2000
G-210	Bonnet	Ductile Iron	ASTM A536 ▼
G-211	Bonnet O-ring	Nitrile	ASTM D2000
G-212	Body	Ductile Iron	ASTM A536 ▼
G-213	Double O-ring**	EPDM	ASTM D2000
G-214	Intermediate ring**	Ductile Iron	ASTM A536 ▼
G-215	Gripper ring**	Ductile Iron	ASTM A536 ▼
G-216	End ring**	Ductile Iron	ASTM A536 ▼
G-217	Breakaway Nut with washer***	Steel	ASTM A108
G-218	T-head Bolt***	Steel	ASTM A242

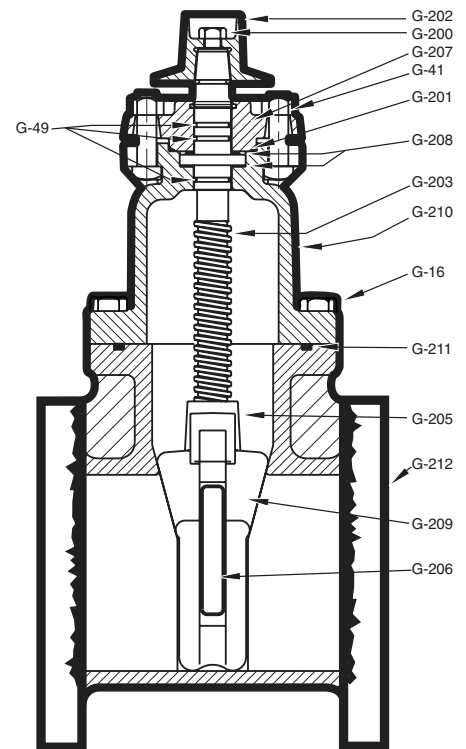

*Fully encapsulated in molded rubber with no iron exposed.

**Parts for Aqua-Grip connection not shown – one required for each Aqua-Grip connection.

***Not shown. See dimension drawing on next page for number require for each size Aqua-Grip connection.

+ Manufacturers option to change material to Ductile iron ASTM A536

▼ Material strength ASTM A536 65-45 minimum

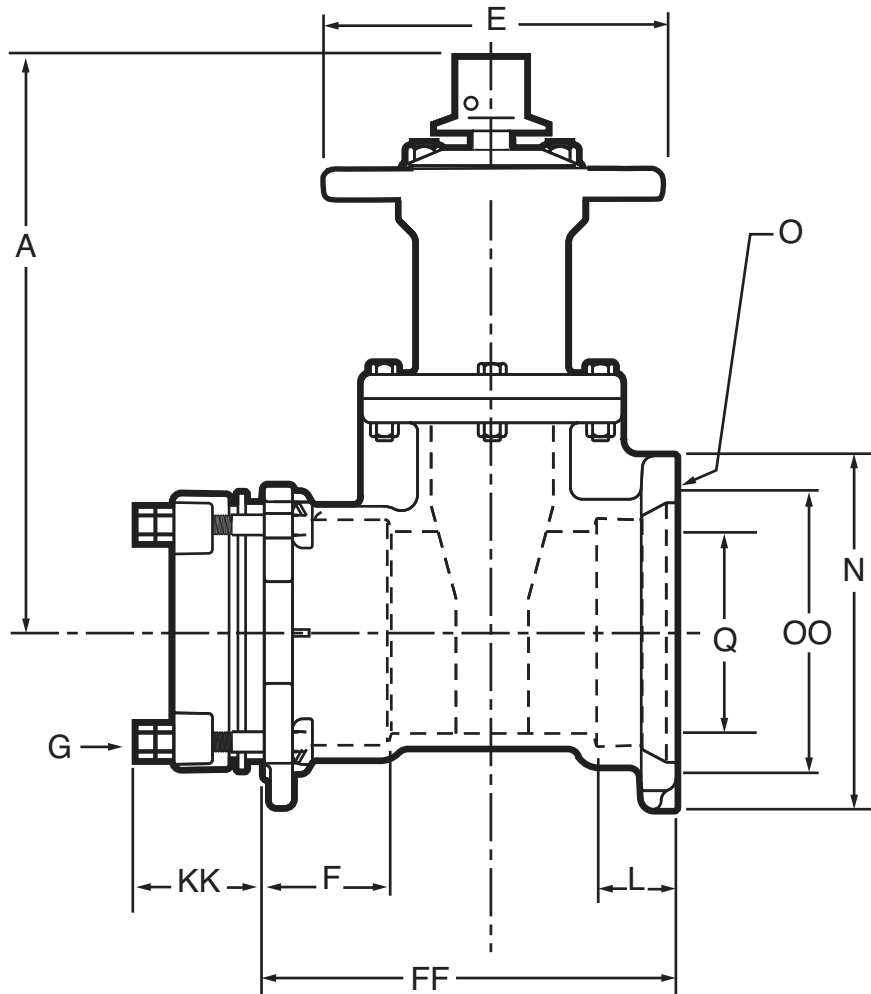

Dimensions

Dimension	Nominal Size				
	4"	6"	8"	10"	12"
A	14.19	18.00	21.50	25.50	28.62
F	3.70	3.70	3.70	3.89	3.89
G (number and size of holes for Aqua-Grip)	4--.88	4--.88	6--.88	8--.88	8--.88
L	2.50	2.50	2.50	2.50	2.50
M	4.90	7.06	9.22	11.20	13.37
N	9.03	11.06	13.31	15.63	17.88
O (number and size of holes for MJ)	4--.88	6--.88	6--.88	8--.88	8--.88
FF	11.34	13.37	14.81	16.4	16.87
Q	4.30	6.30	8.30	10.30	12.30
KK	2.75	3.75	3.75	3.75	3.75
OO (bolt circle diameter for MJ)	7.50	9.50	11.75	14.00	16.25
Turns to open	14	20.5	26.5	33.0	38.5
Weight*	98	151	240	348	467
Closing Torque (FT-LBS), Non-Geared	75	110	150	185	225
Closing Torque (FT-LBS), Bevel	44	65	88	109	132
Closing Torque (FT-LBS), Spur	41	60	82	101	123

Rev. 7-19

- Catalog number—
A-2362-20 Mechanical joint ends (with accessories unassembled)
A-2362-23 Mechanical joint ends (less accessories)
A-2362-25 Mechanical joint ends (with transition gaskets accessories unassembled)
- Sizes – 2", 3", 4", 6", 8", 10", 12"
- Meets or exceeds all applicable requirements of ANSI/AWWA C509, UL 262 Listed, FM 1120/1130 Approved, and certified to ANSI/NSF 61 & 372
- Standard mechanical joint ends comply with ANSI/AWWA C111
- Iron body with nominal 10 mils Mueller Pro-Gard® Fusion Bonded Epoxy Coated interior and exterior surfaces
- Epoxy coating meets or exceeds all applicable requirements of ANSI/AWWA C550 Standard
- Iron wedge, symmetrical and fully encapsulated with molded rubber; no exposed iron
- Non-rising stem (NRS)
- Triple O-ring seal (2 above the thrust collar and 1 below)
- 2" square wrench nut – open left or open right
- 350 psig (2400 kPa/24 barg) maximum working pressure; 700 psig (4800 kPa/48 barg) static test pressure
- UL Listed, FM Approved: 350 psig (2400 kPa/24 barg)
- Designed for potable water applications



A-2362-20 shown

Options

See page 10.54 for more information on Resilient Wedge Gate Valve options

- Position indicators
- Low zinc, silicon bronze ASTM B98-C66100/H02 stem
- Stainless steel stem: Type 304, Type 316
- Handwheel
- EPDM Disc and o-ring

Resilient wedge gate valve parts

Catalog Part Number	Description	Material	Material Standard
G-16	Bonnet Bolts & Nuts	316 Stainless Steel	ASTM F593 (bolt) ASTM F594 (nut)
G-41	Stuffing Box Bolts & Nuts	316 Stainless Steel	ASTM F593 (bolt) ASTM F594 (nut)
G-49	Stem O-rings (3)	Nitrile	ASTM D2000
G-200	Wrench Nut Cap Screw	316 Stainless Steel	ASTM F593
G-201	Stuffing Box O-ring	Nitrile	ASTM D2000
G-202	Wrench Nut	Ductile Iron	ASTM A536 ▼
G-203	Stem	Bronze	ASTM B138
G-204	Hand Wheel (not shown)	Cast Iron +	ASTM A126 CL.B
G-205	Stem Nut	Bronze	ASTM B584
G-206	Guide Cap Bearings	Acetal	-
G-207	Stuffing Box with dirt seal**	Ductile Iron Nitrile	ASTM A536 ▼ ASTM D200
G-208	Anti-friction Washers (2)	Acetal	-
G-209	Wedge, Rubber Encapsulation	Ductile Iron* SBR	ASTM A536 ▼ ASTM D2000
G-210**	Bonnet	Ductile Iron	ASTM A536 ▼
G-211**	Bonnet O-ring ++	Nitrile	ASTM D2000
G-212**	Body	Ductile Iron	ASTMA536 ▼

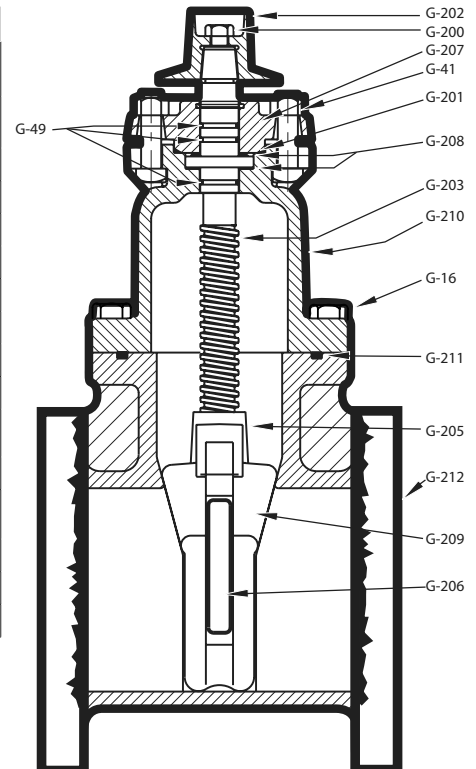

*Fully encapsulated in molded rubber with no iron exposed;
 ▼ Material strength ASTM A536 65-45 minimum
 + Manufacturer's option to change material to ductile iron ASTM A536
 ++ 2"-3" valves use a bonnet gasket
 **Dirt seal on 2 1/2"- 12" valves

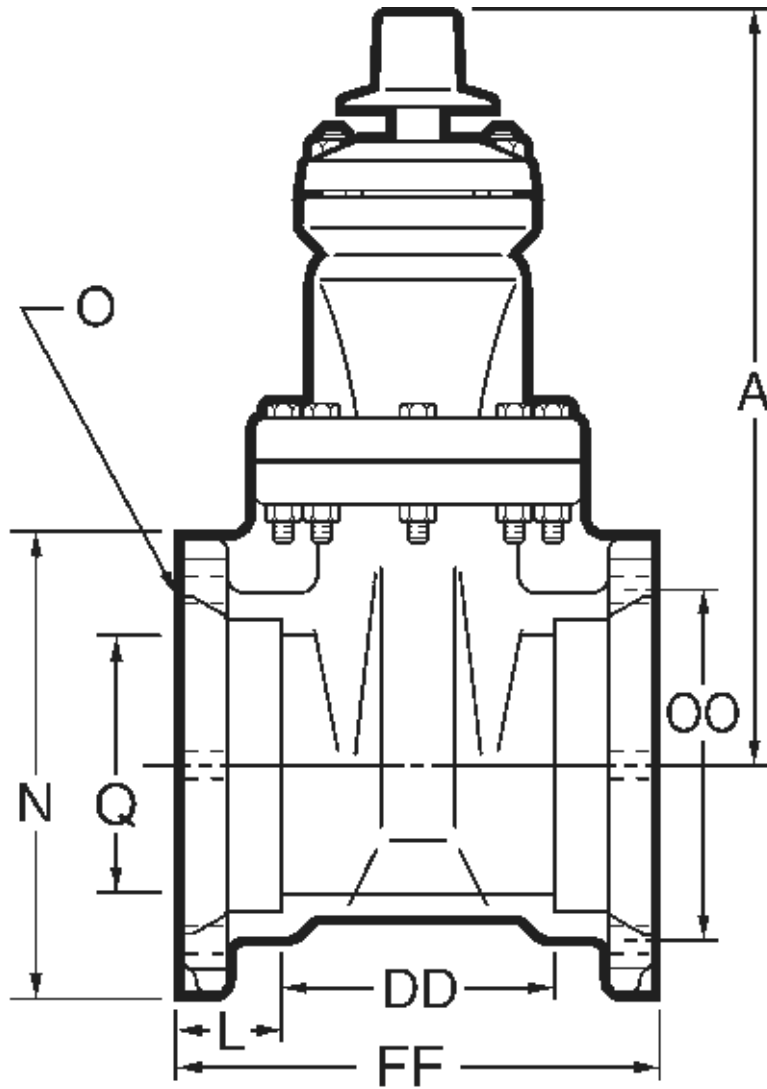

Dimensions

Dimension	Nominal Size							
	2"	2-1/2"	3"	4"	6"	8"	10"	12"
A	9.88		12.38	14.9	18.00	21.50	25.50	28.62
FF	8.50		9.62	10.00	11.60	12.68	14.88	15
L	2.50		2.50	2.50	2.50	2.50	2.50	2.50
N	4.62		7.50	9.12	11.12	13.37	15.62	17.88
O (number and size of holes)	4--.88		4--.88	4--.88	6--.88	6--.88	8--.88	8--.88
DD	3.50		4.62	5.00	6.60	7.68	9.88	10
Q	2.30		3.30	4.30	6.30	8.30	10.30	12.30
OO (bolt circle diameter)	4.75		6.19	7.50	9.50	11.75	14.00	16.25
Turns to open	8		11	14	20.5	26.5	33.0	38.5
Weight*	40		83	120	186	280	405	540
Closing Torque (FT-LBS), Non-Geared	20	28	52	75	110	150	185	225
Closing Torque (FT-LBS), Bevel	N/A	N/A	31	44	65	88	109	132
Closing Torque (FT-LBS), Spur	N/A	N/A	N/A	41	60	82	101	123

*All dimensions are in inches. All weights include accessories are in pounds and are approximate.

Rev. 4-20

- Catalog number
A-2362-6 flanged ends
- Sizes – 2", 2-1/2", 3", 4", 6", 8", 10", 12"
- Meets or exceeds all applicable requirements of ANSI/AWWA C509, UL 262 Listed, FM 1120/1130 Approved, and certified to ANSI/NSF 61 & 372†
- Flanged end drilling complies with ASME/ANSI B16.1 class 125 and B16.42 class 150
- Iron body with nominal 10 mils Pro-Guard® Fusion Bonded Epoxy Coated interior and exterior surfaces
- Epoxy coating meets or exceeds all applicable requirements of ANSI/AWWA C550 Standard
- Iron wedge, symmetrical and fully encapsulated with molded rubber; no exposed iron
- Non-rising stem (NRS)
- Triple O-ring seal (2 above the thrust collar and 1 below)
- 2" square wrench nut – open left or open right
- 350 psig (2400 kPa/34 barg) maximum working pressure; 700 psig (4800 kPa/48 barg) static test pressure
- UL Listed, FM Approved: 350 psig (2400 kPa/24 barg)
- Designed for potable water applications

† Approved for backflow prevention devices by USC (for 4" - 10" sizes)



A-2362-6 shown

Options

See page 10.54 for more information on Resilient Wedge Gate Valve options

- Position indicators
- Low zinc, silicon bronze ASTM B98-C66100/H02 stem
- Stainless steel stem: Type 304, Type 316
- Handwheel
- P/N 10/16 Drilling
- EPDM Disc and O-ring

Resilient wedge gate valve parts

Catalog Part Number	Description	Material	Material Standard
G-16	Bonnet Bolts & Nuts	316 Stainless Steel	ASTM F593 (bolt) ASTM F594 (nut)
G-41	Stuffing Box Bolts & Nuts	316 Stainless Steel	ASTM F593 (bolt) ASTM F594 (nut)
G-49	Stem O-rings (3)	Nitrile	ASTM D2000
G-200	Wrench Nut Cap Screw	316 Stainless Steel	ASTM F593
G-201	Stuffing Box O-ring	Nitrile	ASTM D2000
G-202	Wrench Nut	Ductile Iron	ASTMA536 ▼
G-203	Stem	Bronze	ASTM B138
G-204	Hand Wheel	Cast Iron +	ASTM A126 CL.B
G-205	Stem Nut	Bronze	ASTM B584
G-206	Guide Cap Bearings	Acetal	-
G-207	Stuffing Box with dirt seal**	Ductile Iron Nitrile	ASTM A536 ▼ ASTM D2000
G-208	Anti-friction Washers (2)	Acetal	-
G-209	Wedge, Rubber Encapsulation	Ductile Iron* SBR	ASTMA536 ▼ ASTM D2000
G-210**	Bonnet	Ductile Iron	ASTMA536 ▼
G-211**	Bonnet O-ring ++	Nitrile	ASTM D2000
G-212**	Body	Ductile Iron	ASTMA536 ▼

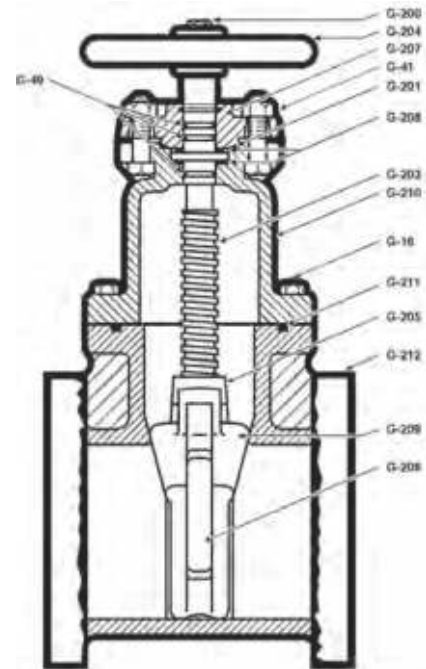

*Fully encapsulated in molded rubber with no iron exposed;

▼ Material strength ASTM A536 65-45 minimum

+ Manufacturer's option to change material to ductile iron ASTM A536

++ 2"-3" valves use a bonnet gasket

**Dirt seal on 2 1/2" - 12" valves

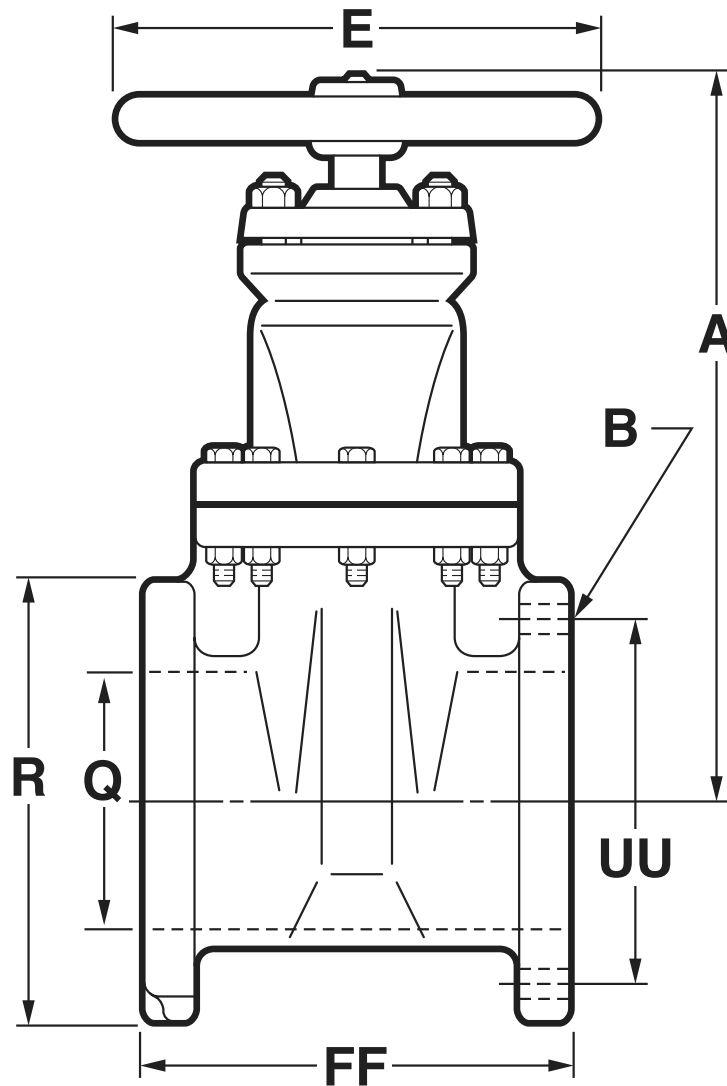

Dimensions

Dimension	Nominal Size							
	2"	2-1/2"	3"	4"	6"	8"	10"	12"
A	9.88	12.38	12.38	14.19	18.00	21.50	25.50	28.62
E	6.00	6.00	8.00	11.00	13.00	14.00	16.00	16.00
R	6.00	7.00	7.50	9.00	11.00	13.50	16.00	19.00
FF	7.00	7.50	8.00	9.00	10.50	11.50	13.00	14.00
Q (bore)	2.30	2.80	3.30	4.30	6.30	8.30	10.30	12.30
UU (bolt circle diameter)	4.75	5.50	6.00	7.50	9.50	11.75	14.25	17.00
B (number and size of holes)	4--.75	4--.75	4--.75	8--.75	8--.88	8--.88	12--1.00	12--1.00
Turns to open	8	11	11	14	20.5	26.5	33	38.5
Weight*	37	71	73	96	154	250	392	522
Closing Torque (FT-LBS), Non-Geared	20	28	52	75	110	150	185	225
Closing Torque (FT-LBS), Bevel	N/A	N/A	31	44	65	88	109	132
Closing Torque (FT-LBS), Spur	N/A	N/A	N/A	41	60	82	101	123

*All dimensions are in inches. All weights are in pounds and are approximate.

Rev. 7-19

- Catalog number
A-2362-12 Class 250 flanged ends
- Sizes – 3", 4", 6", 8", 10", 12"
- Meets or exceeds all applicable requirements of ANSI/AWWA C509, UL 262 Listed, FM 1120/1130 Approved, and certified to ANSI/NSF 61 & 372†
- Flanged end drilling complies with ASME/ANSI B16.1 class 250
- Iron body with nominal 10 mils Pro-Guard® Fusion Bonded Epoxy Coated interior and exterior surfaces
- Epoxy coating meets or exceeds all applicable requirements of ANSI/AWWA C550 Standard
- Iron wedge, symmetrical and fully encapsulated with molded rubber; no exposed iron
- Non-rising stem (NRS)
- Triple O-ring seal (2 above the thrust collar and 1 below)
- 2" square wrench nut – open left or open right
- 350 psig (2400 kPa/34 barg) maximum working pressure; 700 psig (4800 kPa/48 barg) static test pressure
- UL Listed, FM Approved: 350 psig (2400 kPa/24 barg)
- Designed for potable water applications

† Approved for backflow prevention devices by USC (for 4" - 10" sizes)



A-2362-12 shown

Options

See page 10.54 for more information on Resilient Wedge Gate Valve options

- Position indicators
- Stainless steel stem: Type 304, Type 316
- EPDM Disc and O-ring
- Low zinc, silicon bronze ASTM B98-C66100/H02 stem
- Handwheel
- P/N 25 Drilling

Resilient wedge gate valve parts

Catalog Part Number	Description	Material	Material Standard
G-16	Bonnet Bolts & Nuts	316 Stainless Steel	ASTM F593 (bolt) ASTM F594 (nut)
G-41	Stuffing Box Bolts & Nuts	316 Stainless Steel	ASTM F593 (bolt) ASTM F594 (nut)
G-49	Stem O-rings (3)	Nitrile	ASTM D2000
G-200	Wrench Nut Cap Screw	316 Stainless Steel	ASTM F593
G-201	Stuffing Box O-ring	Nitrile	ASTM D2000
G-202	Wrench Nut	Ductile Iron	ASTM A536 ▼
G-203	Stem	Bronze	ASTM B138
G-204	Hand Wheel	Cast Iron +	ASTM A126 CL.B
G-205	Stem Nut	Bronze	ASTM B584
G-206	Guide Cap Bearings	Acetal	-
G-207	Stuffing Box with dirt seal	Ductile Iron Nitrile	ASTM A536 ▼ ASTM D2000
G-208	Anti-friction Washers (2)	Acetal	-
G-209	Wedge, Rubber Encapsulation	Ductile Iron* SBR	ASTM A536 ▼ ASTM D2000
G-210**	Bonnet	Ductile Iron	ASTM A536 ▼
G-211**	Bonnet O-ring ++	Nitrile	ASTM D2000
G-212**	Body	Ductile Iron	ASTM A536 ▼

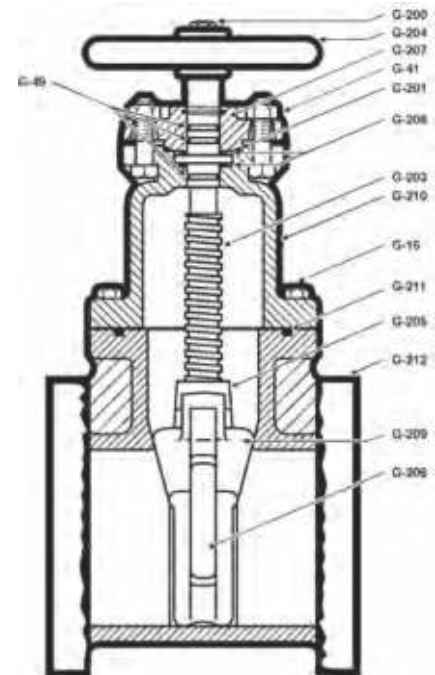

*Fully encapsulated in molded rubber with no iron exposed;

▼ Material strength ASTM A536 65-45 minimum

+ Manufacturer's option to change material to ductile iron ASTM A536

++ 2-3" valves use a bonnet gasket

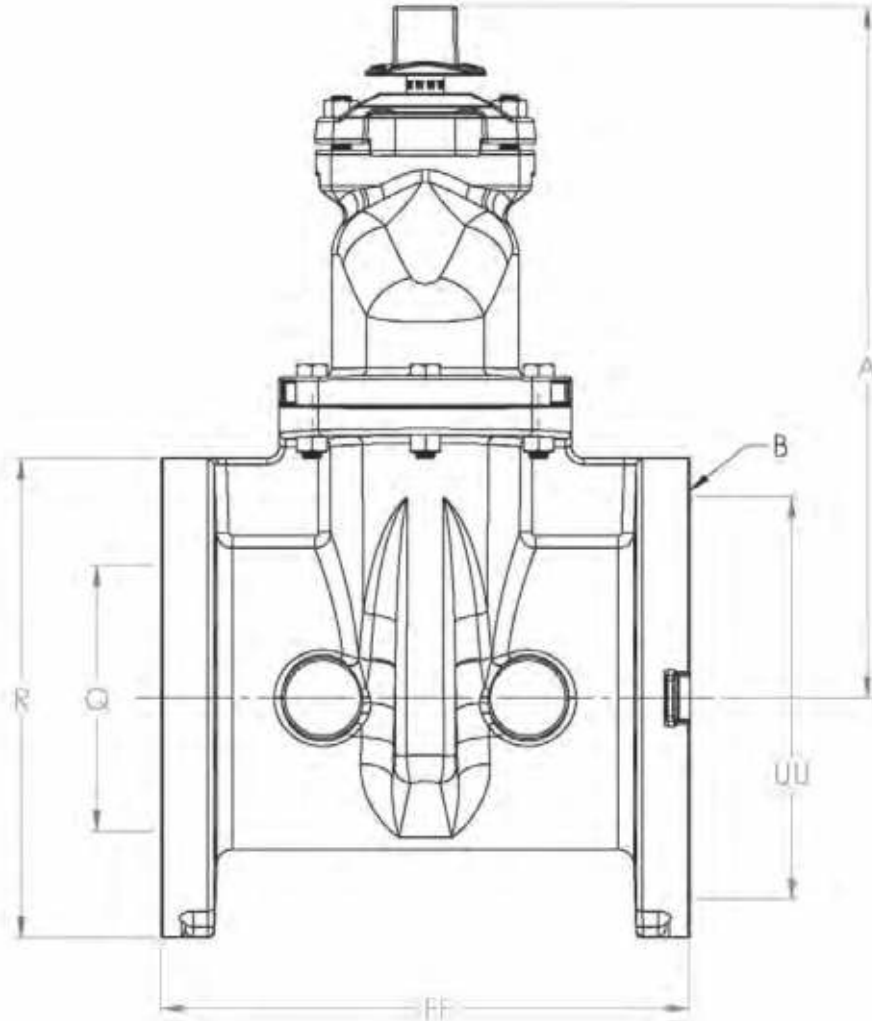

Dimensions

Dimension	3"	4"	6"	8"	10"	12"
	A	12.38	14.19	18.00	21.50	25.50
Rt	9.00	10.00	12.50	15.00	17.50	20.50
FF	11.10	12.00	15.86	16.50	18.00	19.75
Q (bore)	3.30	4.30	6.30	8.30	10.30	12.30
UU (bolt circle diameter)	6.63	7.87	10.63	12.99	15.24	17.76
B (number and size of holes)	8--.88	8--.88	12--.88	12--1.125	16--1.25	16--1.25
Turns to open	11	14	20.5	26.5	33	38.5
Weight*	85	121	202	328	519	674
Closing Torque (FT-LBS), Non-Geared	52	75	110	150	185	225
Closing Torque (FT-LBS), Bevel	31	44	65	88	109	132
Closing Torque (FT-LBS), Spur	N/A	41	60	82	101	123

*All dimensions are in inches. All weights are in pounds and are approximate.

Rev. 5-18

- Catalog number
 - A-2362-16** mechanical joint x flanged ends (with accessories unassembled)
 - A-2362-19** mechanical joint x flanged ends (less accessories)
- Sizes – 2", 3", 4", 6", 8", 10", 12"
- Meets or exceeds all applicable requirements of ANSI/AWWA C509, UL 262 Listed, FM 1120/1130 Approved, and certified to ANSI/NSF 61 & 372
- Flanged end drilling complies with ASME/ANSI B16.1 class 125 and B16.42 class 150
- Mechanical joint end complies with ANSI/AWWA C111 Standard
- Iron body with nominal 10 mils Pro-Guard® Fusion Bonded Epoxy Coated interior and exterior surface
- Epoxy coating meets or exceeds all applicable requirements of ANSI/AWWA C550 Standard
- Iron wedge, symmetrical and fully encapsulated with molded rubber; no exposed iron
- Non-rising stem (NRS)
- Triple O-ring seal (2 above the thrust collar and 1 below)
- 2" square wrench nut – open left or open right
- 350 psig (2400 kPa/24 barg) maximum working pressure; 700 psig (4800 kPa/48 barg) static test pressure
- UL Listed, FM Approved: 250 psig (1725 kPa/17 barg)
- Designed for potable water applications



A-2362-16 shown
M.J. accessories
shipped unassembled

Options

See page 10.54 for more information on Resilient Wedge Gate Valve options

- Position indicators
- Low zinc, silicon bronze ASTM B98-C66100/H02 stem
- Stainless steel stem: Type 304, Type 316
- Handwheel
- EPDM Disc and O-rings

Resilient wedge gate valve parts

Catalog Part Number	Description	Material	Material Standard
G-16	Bonnet Bolts & Nuts	316 Stainless Steel	ASTM F593 (bolt) ASTM F594 (nut)
G-41	Stuffing Box Bolts & Nuts	316 Stainless Steel	ASTM F593 (bolt) ASTM F594 (nut)
G-49	Stem O-rings (3)	Nitrile	ASTM D2000
G-200	Wrench Nut Cap Screw	316 Stainless Steel	ASTM F593
G-201	Stuffing Box O-ring	Nitrile	ASTM D2000
G-202	Wrench Nut	Ductile Iron	ASTM A536 ▼
G-203	Stem	Bronze	ASTM B138
G-204	Hand Wheel (not shown)	Cast Iron +	ASTM A126 CL.B
G-205	Stem Nut	Bronze	ASTM B584
G-206	Guide Cap Bearings	Acetal	-
G-207	Stuffing Box with dirt seal**	Ductile Iron Nitrile	ASTM A536 ▼ ASTM D2000
G-208	Anti-friction Washers (2)	Acetal	-
G-209	Wedge, Rubber Encapsulation	Ductile Iron* SBR	ASTM A536 ▼ ASTM D2000
G-210**	Bonnet	Ductile Iron	ASTM A536 ▼
G-211**	Bonnet O-ring ++	Nitrile	ASTM D2000
G-212**	Body	Ductile Iron	ASTM A536 ▼

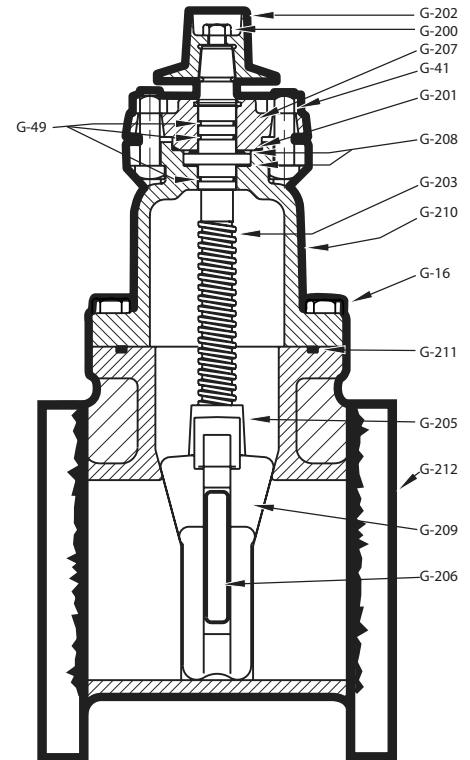

*Fully encapsulated in molded rubber with no iron exposed;
 ▼ Material strength ASTM A536 65-45 minimum
 + Manufacturer's option to change material to ductile iron ASTM A536
 ++ 2"-3" valves use a bonnet gasket
 **Dirt seal on 2 1/2 -12" valves

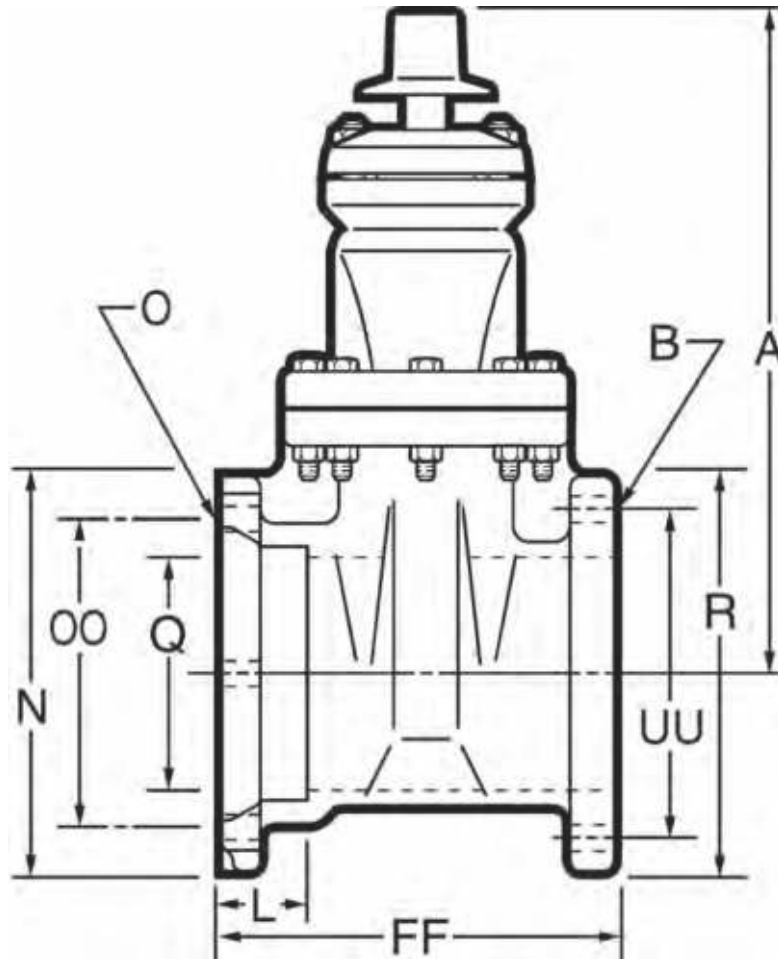

Dimensions

Dimension	Nominal Size							
	2"	2-1/2"	3"	4"	6"	8"	10"	12"
A	9.88		12.38	14.19	18.00	21.50	25.50	28.62
L	2.50		2.50	2.50	2.50	2.50	2.50	2.50
N	4.62		7.50	9.12	11.12	13.37	15.62	17.88
O	4--.75		4--.75	4--.88	6--.88	6--.88	8--.88	8--.88
Q (bore)	2.30		3.30	4.30	6.30	8.30	10.30	12.30
OO (bolt circle diameter)	4.75		6.19	7.50	9.50	11.75	14.00	16.25
R	6.00		7.50	9.00	11.00	13.50	16.00	19.00
UU	4.75		6.00	7.50	9.50	11.75	14.25	17.00
FF	8.39		8.8	9.50	11.06	12.09	13.94	14.50
B (numbers and size holes)	4--.75		4--.75	8--.75	8--.88	8--.88	12--1.00	12--1.00
Turns to open	8		11	14	20.5	26.5	33	38.5
Weight*	56		67	115	168	275	400	570
Closing Torque (FT-LBS), Non-Geared	20	28	52	75	110	150	185	225
Closing Torque (FT-LBS), Bevel	N/A	N/A	31	44	65	88	109	132
Closing Torque (FT-LBS), Spur	N/A	N/A	N/A	41	60	82	101	123

* All dimensions are in inches. All weights include accessories are in pounds and are approximate.

Rev. 5-18

- Catalog number
A-2362-38 Slip-on ends with gasket
A-2362-40 Slip-on ends less gasket
- Sizes – 4", 6", 8", 10", 12"
- Meets or exceeds all applicable requirements of ANSI/AWWA C509, UL 262 Listed, FM 1120/1130 Approved, and certified to ANSI/NSF 61 & 372
- Slip-on ends fit plain end of classes 150, 200 and 250 cast iron; ductile iron and classes 150 and 200 cast iron O.D. PVC
- Iron body with nominal 10 mils Mueller Pro-Gard® Fusion Bonded Epoxy Coated interior and exterior surfaces
- Epoxy coating meets or exceeds all applicable requirements of ANSI/AWWA C550 Standard
- Iron wedge, symmetrical and fully encapsulated with molded rubber; no exposed iron
- Non-rising stem (NRS)
- Triple O-ring seal (2 above the thrust collar and 1 below)
- 2" square wrench nut – open left or open right
- 350 psig (2400 kPa/24 barg) maximum working pressure; 700 psig (4800 kPa/48 barg) static test pressure
- UL Listed, FM Approved: 350 psig (2400 kPa/24 barg)
- Designed for potable water applications

++ Field Lok is a trademark of U.S. Pipe and Foundry Company, used with permission



A-2362-38 shown

Slip-on ends on this valve are not intended for use with Field Lok†† restrained gaskets. Use valve on page 10.13A

Options

See page 10.54 for more information on Resilient Wedge Gate Valve options

- Position indicators
- Low zinc, silicon bronze ASTM B98-C66100/H02 stem
- Stainless steel stem: Type 304, Type 316
- Handwheel
- EPDM Disc and O-rings

Resilient wedge gate valve parts

Catalog Part Number	Description	Material	Material Standard
G-16	Bonnet Bolts & Nuts	316 Stainless Steel	ASTM F593 (bolt) ASTM F594 (nut)
G-41	Stuffing Box Bolts & Nuts	316 Stainless Steel	ASTM F593 (bolt) ASTM F594 (nut)
G-49	Stem O-rings (3)	Nitrile	ASTM D2000
G-200	Wrench Nut Cap Screw	316 Stainless Steel	ASTM F593
G-201	Stuffing Box O-ring	Nitrile	ASTM D2000
G-202	Wrench Nut	Ductile Iron	ASTM A536 ▼
G-203	Stem	Bronze	ASTM B138
G-204	Hand Wheel (not shown)	Cast Iron +	ASTM A126 CL.B
G-205	Stem Nut	Bronze	ASTM B584
G-206	Guide Cap Bearings	Acetal	-
G-207	Stuffing Box with dirt seal	Ductile Iron Nitrile	ASTM A536 ▼ ASTM D2000
G-208	Anti-friction Washers (2)	Acetal	-
G-209	Wedge, Rubber Encapsulation	Ductile Iron SBR*	ASTM A536 ▼ ASTM D2000
G-210	Bonnet	Ductile Iron	ASTM A536 ▼
G-211	Bonnet O-ring	Nitrile	ASTM D2000
G-212	Body	Ductile Iron	ASTM A536 ▼

*Fully encapsulated in molded rubber with no iron exposed

▼ Material strength ASTM A536 65-45 minimum

+ Manufacturer's option to change material to ductile iron ASTM A536

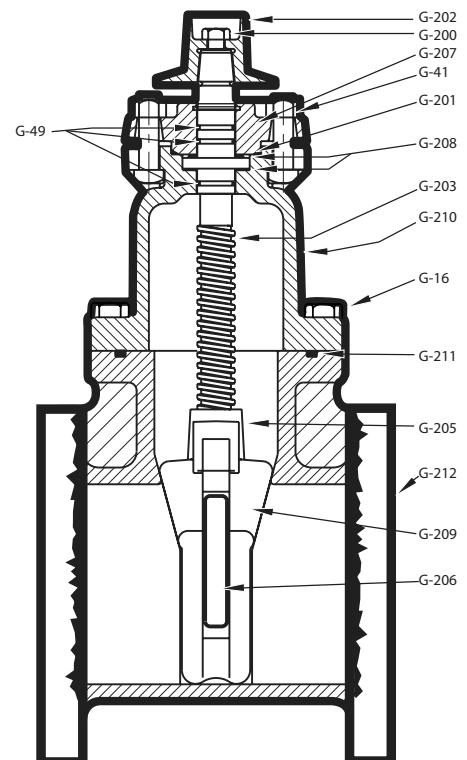

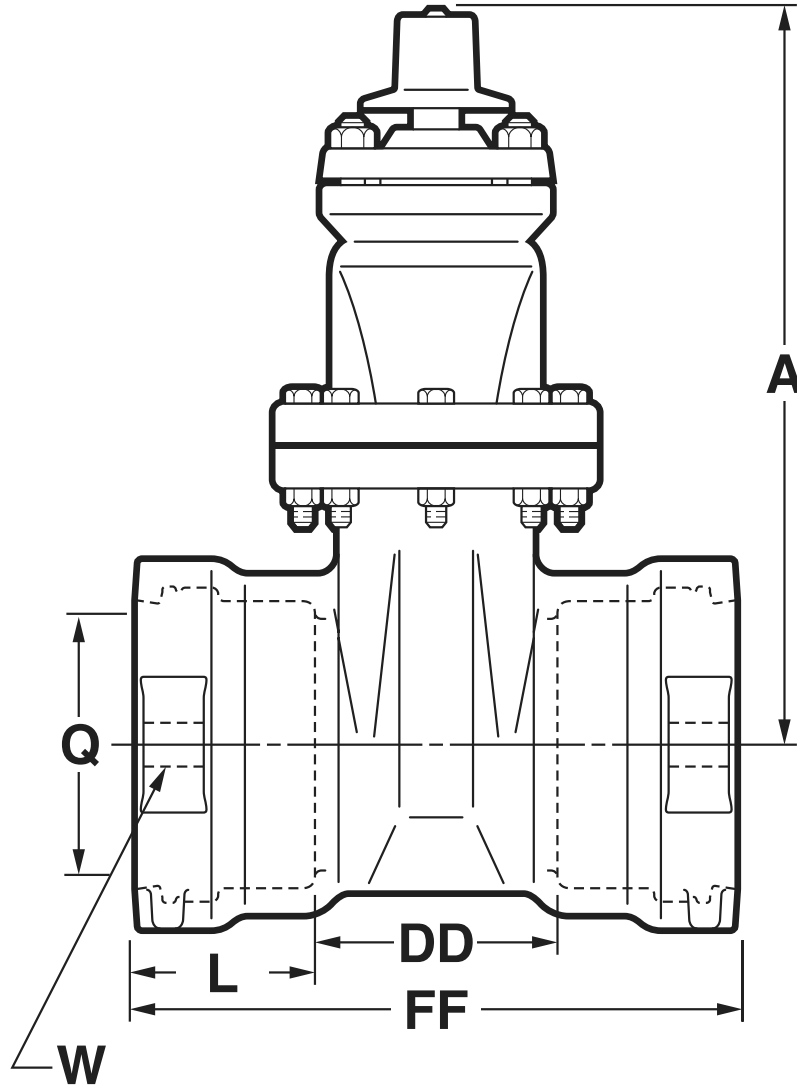

Dimensions

Dimension	Nominal Size				
	4"	6"	8"	10"	12"
A	14.19	18.00	21.50	25.50	28.62
Q (bore)	4.30	6.30	8.30	10.30	12.30
W (distance between strapping lug holes across face of valve ends)	8.62	10.62	13.12	16.38	18.12
FF	12.81	14.96	17.94	18.50	18.70
L	4.12	4.38	5.62	5.62	5.62
DD	4.57	6.20	6.70	7.26	7.46
Turns to open	14	20.5	26.5	33	38.5
Weight*	101	156	252	373	499
Closing Torque (FT-LBS), Non-Geared	75	110	150	185	225
Closing Torque (FT-LBS), Bevel	44	65	88	109	132
Closing Torque (FT-LBS), Spur	41	60	82	101	123

*All dimensions are in inches. All weights are in pounds and are approximate.

Rev. 5-18

- Catalog number
A-2362-41 Slip-on end (with gasket) x flange end
A-2362-43 Slip-on end (less gasket) x flange end
- Sizes – 4", 6", 8", 10", 12"
- Meets or exceeds all applicable requirements of ANSI/AWWA C509, UL 262 Listed, FM 1120/1130 Approved, and certified to ANSI/NSF 61 & 372
- Slip-on ends fit plain end of classes 150, 200 and 250 cast iron, ductile iron and classes 150 and 200 cast iron O.D. PVC
- Flanged end drilling complies with ASME/ANSI B16.1 class 125 and B16.42 class 150
- Iron body with nominal 10 mils Mueller Pro-Gard® Fusion Bonded Epoxy Coated interior and exterior surfaces
- Epoxy coating meets or exceeds all applicable requirements of ANSI/AWWA C550 Standard
- Iron wedge, symmetrical and fully encapsulated with molded rubber; no exposed iron
- Non-rising stem (NRS)
- Triple O-ring seal (2 above the thrust collar and 1 below)
- 2" square wrench nut – open left or open right
- 350 psig (2400 kPa/24 barg) maximum working pressure; 700 psig (4800 kPa/48 barg) static test pressure
- UL Listed, FM Approved: 350 psig (2400 kPa/24 barg)
- Designed for potable water applications

††Field Lok is a trademark of U.S. Pipe and Foundry Company, used with permission.



A-2362-41 shown

Slip-on end on this valve is not intended for use with Field Lok†† restrained gaskets. Use valve on page 10.13C

Options

See page 10.54 for more information on Resilient Wedge Gate Valve options

- Position indicators
- Stainless steel stem: Type 304, Type 316
- EPDM Disc and O-rings
- Low zinc, silicon bronze ASTM B98-C66100/H02 stem
- Handwheel

Resilient wedge gate valve parts

Catalog Part Number	Description	Material	Material Standard
G-16	Bonnet Bolts & Nuts	316 Stainless Steel	ASTM F593 (bolt) ASTM F594 (nut)
G-41	Stuffing Box Bolts & Nuts	316 Stainless Steel	ASTM F593 (bolt) ASTM F594 (nut)
G-49	Stem O-rings (3)	Nitrile	ASTM D2000
G-200	Wrench Nut Cap Screw	316 Stainless Steel	ASTM F593
G-201	Stuffing Box O-ring	Nitrile	ASTM D2000
G-202	Wrench Nut	Ductile Iron	ASTM A536 ▼
G-203	Stem	Bronze	ASTM B138
G-204	Hand Wheel (not shown)	Cast Iron +	ASTM A126 CL.B
G-205	Stem Nut	Bronze	ASTM B584
G-206	Guide Cap Bearings	Acetal	-
G-207	Stuffing Box with dirt seal	Ductile Iron Nitrile	ASTM A536 ▼ ASTM D2000
G-208	Anti-friction Washers (2)	Acetal	-
G-209	Wedge, Rubber Encapsulation	Ductile Iron* SBR	ASTM A536 ▼ ASTM D2000
G-210	Bonnet	Ductile Iron	ASTM A536 ▼
G-211	Bonnet O-ring	Nitrile	ASTM D2000
G-212	Body	Ductile Iron	ASTM A536 ▼

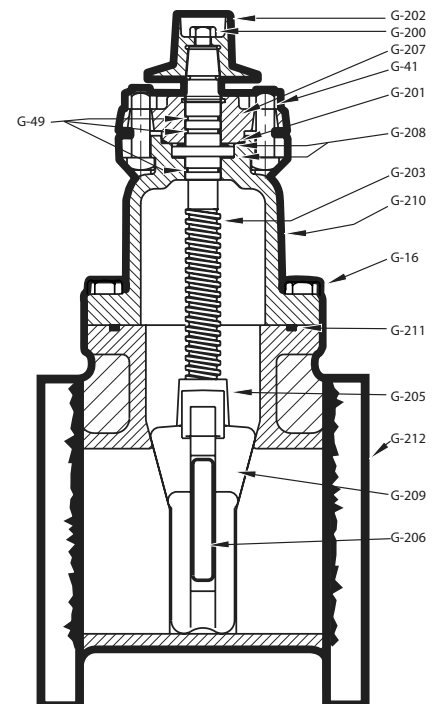

*Fully encapsulated in molded rubber with no iron exposed

▼ Material strength ASTM A536 65-45 minimum

+ Manufacturer's option to change material to ductile iron ASTM A536

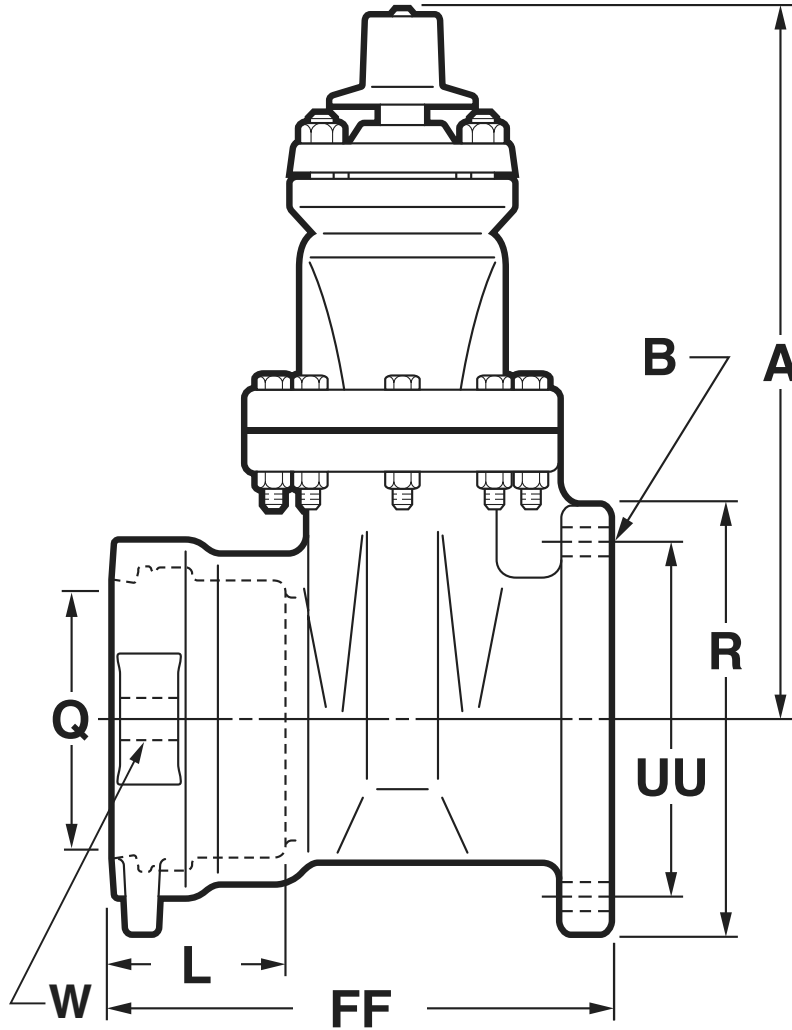

Dimensions

Dimension	Nominal Size				
	4"	6"	8"	10"	12"
A	14.19	18.00	21.50	25.50	28.62
Q (bore)	4.30	6.30	8.30	10.30	12.30
L	4.12	4.38	5.62	5.62	5.62
R	9.00	11.00	13.50	16.00	19.00
UU (bolt circle diameter for FL)	7.50	9.50	11.75	14.25	17.00
B (number and size of holes for FL)	8--.75	8--.88	8--.88	12--1.00	12--1.00
W (distance between strapping lug holes across face of valve ends)	8.62	10.62	13.12	16.38	18.12
FF	10.91	12.73	14.72	15.75	16.35
Turns to open	14	20.5	26.5	33	38.5
Weight*	98	152	244	366	489
Closing Torque (FT-LBS), Non-Geared	75	110	150	185	225
Closing Torque (FT-LBS), Bevel	44	65	88	109	132
Closing Torque (FT-LBS), Spur	41	60	82	101	123

*All dimensions are in inches. All weights are in pounds and are approximate.

Rev. 5-18

- Catalog number–
A-2362-61 Slip On ends (less Field Lok gaskets)
- Sizes – 4", 6", 8", 12"
- Meets or exceeds all applicable requirements of ANSI/AWWA C509, UL 262 Listed, FM 1120/1130 Approved, and certified to ANSI/NSF 61 & 372
- Slip-on ends with Field Lok gaskets are to be used on ductile iron pipe
- Iron body with nominal 10 mils Mueller Pro-Gard® Fusion Bonded Epoxy Coated interior and exterior surfaces
- Epoxy coating meets or exceeds all applicable requirements of ANSI/AWWA C550 Standard
- Iron wedge, symmetrical and fully encapsulated with molded rubber; no exposed iron
- Non-rising stem (NRS)
- Triple O-ring seal (2 above the thrust collar and 1 below)
- 2" square wrench nut – open left or open right
- 350 psig (2400 kPa/24 barg) maximum working pressure; 700 psig (4800 kPa/48 barg) static test pressure
- UL Listed, FM Approved: 350 psig (2400 kPa/24 barg)
- Designed for potable water applications



A-2362-61 shown

Slip-on ends on this valve are intended for use with Field Lok†† restrained gaskets.

†Design and dimensions of the joint are manufactured under license of U.S. Pipe and Foundry Company.
 ††Field Lok is a trademark of U.S. Pipe and Foundry Company, used with permission.

Options

See page 10.54 for more information on Resilient Wedge Gate Valve options

- Position indicators
- Stainless steel stem: Type 304, Type 316
- EPDM Disc and O-rings
- Low zinc, silicon bronze ASTM B98-C66100/H02 stem
- Handwheel

Resilient wedge gate valve parts

Catalog Part Number	Description	Material	Material Standard
G-16	Bonnet Bolts & Nuts	316 Stainless Steel	ASTM F593 (bolt) ASTM F594 (nut)
G-41	Stuffing Box Bolts & Nuts	316 Stainless Steel	ASTM F593 (bolt) ASTM F594 (nut)
G-49	Stem O-rings (3)	Nitrile	ASTM D2000
G-200	Wrench Nut Cap Screw	316 Stainless Steel	ASTM F593
G-201	Stuffing Box O-ring	Nitrile	ASTM D2000
G-202	Wrench Nut	Ductile Iron	ASTM A536 ▼
G-203	Stem	Bronze	ASTM B138
G-204	Hand Wheel (not shown)	Cast Iron +	ASTM A126 CL.B
G-205	Stem Nut	Bronze	ASTM B584
G-206	Guide Cap Bearings	Acetal	-
G-207	Stuffing Box with dirt seal	Ductile Iron Nitrile	ASTM A536 ▼ ASTM D2000
G-208	Anti-friction Washers (2)	Acetal	-
G-209	Wedge, Rubber Encapsulation	Ductile Iron* SBR	ASTM A536 ▼ ASTM D2000
G-210	Bonnet	Ductile Iron	ASTM A536 ▼
G-211	Bonnet O-ring	Nitrile	ASTM D2000
G-212	Body	Ductile Iron	ASTM A536 ▼

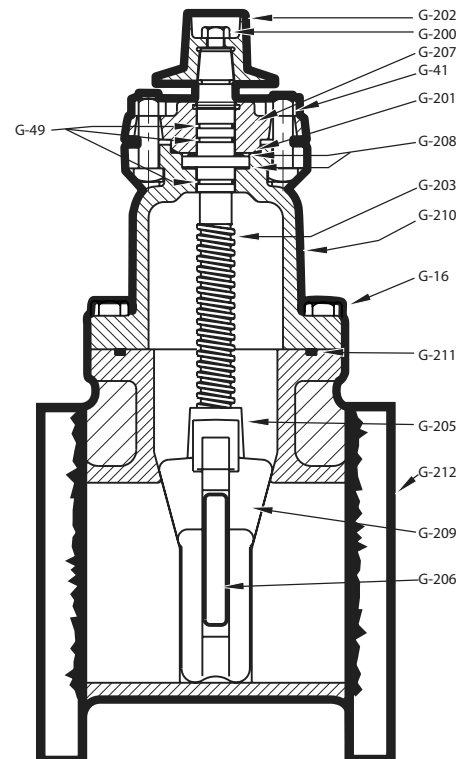

*Fully encapsulated in molded rubber with no iron exposed

▼ Material strength ASTM A536 65-45 minimum

+ Manufacturer's option to change material to ductile iron ASTM A536

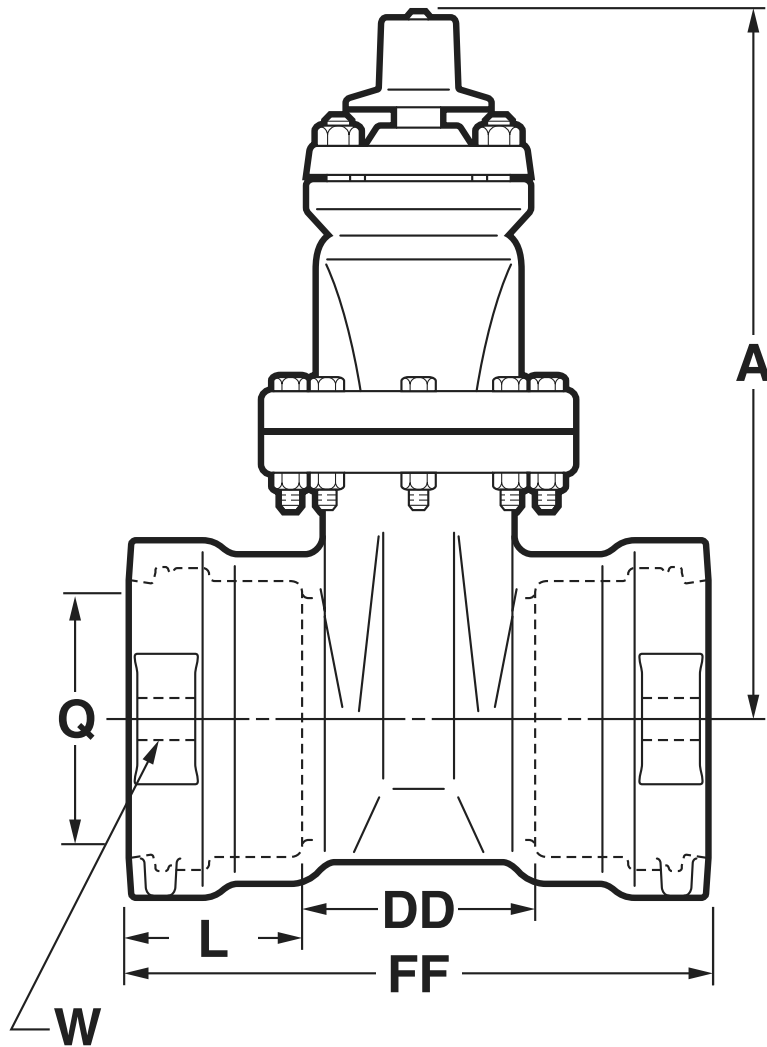

Dimensions

Dimension	Nominal Size				
	4"	6"	8"	10"	12"
A	14.19	18.00	21.50		28.62
Q (bore)	4.30	6.30	8.30		12.30
W (distance between strapping lug holes across face of valve ends)	8.62	10.62	13.12		18.12
FF	12.81	14.96	17.94		18.70
L	4.12	4.38	5.62		5.62
DD	4.57	6.2	6.7		7.46
Turns to open	14	20.5	26.5		38.5
Weight*	101	156	252		499
Closing Torque (FT-LBS), Non-Geared	75	110	150	185	225
Closing Torque (FT-LBS), Bevel	44	65	88	109	132
Closing Torque (FT-LBS), Spur	41	60	82	101	123

*All dimensions are in inches. All weights are in pounds and are approximate.

**Field Lok is a trademark of U.S. Pipe and Foundry Company, used with permission.

Rev. 5-18

- Catalog number
A-2362-62 Slip On (less Field Lok gasket) x flange end
- Sizes – 4", 6", 8", 12"
- Meets or exceeds all applicable requirements of ANSI/AWWA C509, UL 262 Listed, FM 1120/1130 Approved, and certified to ANSI/NSF 61 & 372
- Slip-on ends with Field Lok gaskets are to be used on ductile iron pipe
- Flanged end drilling complies with ASME/ANSI B16.1 class 125 and B16.42 class 150
- Iron body with nominal 10 mils Mueller Pro-Gard® Fusion Bonded Epoxy Coated interior and exterior surfaces
- Epoxy coating meets or exceeds all applicable requirements of ANSI/AWWA C550 Standard
- Iron wedge, symmetrical and fully encapsulated with molded rubber; no exposed iron
- Non-rising stem (NRS)
- Triple O-ring seal (2 above the thrust collar and 1 below)
- 2" square wrench nut – open left or open right
- 350 psig (2400 kPa/24 barg) maximum working pressure; 700 psig (4800 kPa/48 barg) static test pressure
- UL Listed, FM Approved: 350 psig (2400 kPa/24 barg)
- Designed for potable water applications



A-2362-62 shown

Slip-on end on this valve is intended for use with Field Lok†† restrained gaskets.

†Design and dimensions of the joint are manufactured under license of U.S. Pipe and Foundry Company.
 ††Field Lok is a trademark of U.S. Pipe and Foundry Company, used with permission.

Options

See page 10.54 for more information on Resilient Wedge Gate Valve options

- Position indicators
- Low zinc, silicon bronze ASTM B98-C66100/H02 stem
- Stainless steel stem: Type 304, Type 316
- Handwheel
- EPDM Disc and O-rings

Resilient wedge gate valve parts

Catalog Part Number	Description	Material	Material Standard
G-16	Bonnet Bolts & Nuts	316 Stainless Steel	ASTM F593 (bolt) ASTM F594 (nut)
G-41	Stuffing Box Bolts & Nuts	316 Stainless Steel	ASTM F593 (bolt) ASTM F594 (nut)
G-49	Stem O-rings (3)	Nitrile	ASTM D2000
G-200	Wrench Nut Cap Screw	316 Stainless Steel	ASTM F593
G-201	Stuffing Box O-ring	Nitrile	ASTM D2000
G-202	Wrench Nut	Ductile Iron	ASTM A536 ▼
G-203	Stem	Bronze	ASTM B138
G-204	Hand Wheel (not shown)	Cast Iron +	ASTM A126 CL.B
G-205	Stem Nut	Bronze	ASTM B584
G-206	Guide Cap Bearings	Acetal	-
G-207	Stuffing Box with dirt seal	Ductile Iron Nitrile	ASTM A536 ▼ ASTM D2000
G-208	Anti-friction Washers (2)	Acetal	-
G-209	Wedge, Rubber Encapsulation	Ductile Iron* SBR	AASMA536 ▼ ASTM D2000
G-210**	Bonnet	Ductile Iron	ASTM A536 ▼
G-211**	Bonnet O-ring	Nitrile	ASTM D2000
G-212**	Body	Ductile Iron	ASTM A536 ▼

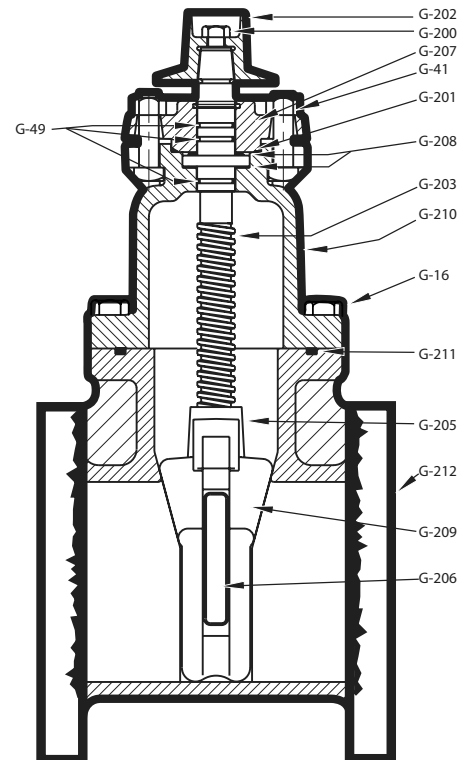

*Fully encapsulated in molded rubber with no iron exposed

▼ Material strength ASTM A536 65-45 minimum

+ Manufacturer's option to change material to ductile iron ASTM A536

4"- 12" A-2362 RESILIENT WEDGE GATE VALVES - SL. x FL. (FOR FIELD LOK™ †† GASKETS)

MUELLER

10.55

Rev. 1-22

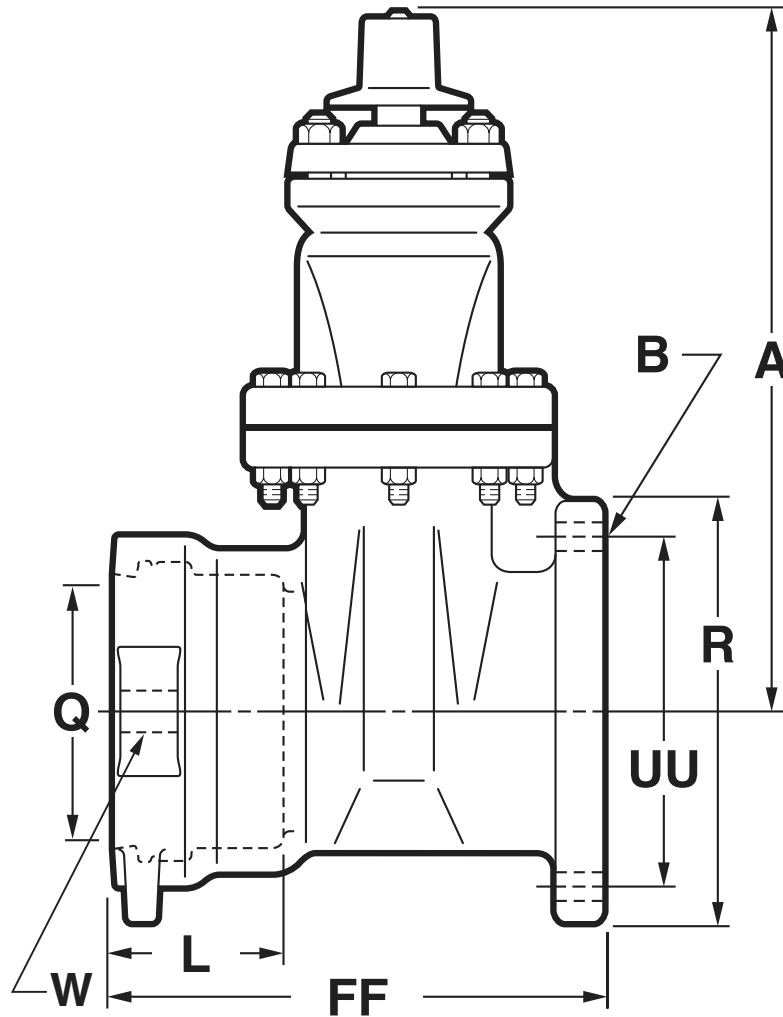

Dimensions

Dimension	Nominal Size				
	4"	6"	8"	10"	12"
A	14.19	18.00	21.50	25.50	28.62
Q (bore)	4.30	6.30	8.30	10.30	12.30
L	4.12	4.38	5.62	5.62	5.62
R	9.00	11.00	13.50	16.00	19.00
UU (bolt circle diameter for FL)	7.50	9.50	11.75	14.25	17.00
B (number and size of holes for FL)	8--.75	8--.88	8--.88	12--1.00	12--1.00
W (distance between strapping lug holes across face of valve ends)	8.62	10.62	13.12	16.38	18.12
FF	10.91	12.73	14.72	15.75	16.35
Turns to open	14	20.5	26.5	33	38.5
Weight*	98	152	260	400	565
Closing Torque (FT-LBS), Non-Geared	75	110	150	185	225
Closing Torque (FT-LBS), Bevel	44	65	88	109	132
Closing Torque (FT-LBS), Spur	41	60	82	101	123

*All dimensions are in inches. All weights are in pounds and are approximate.
 **Field Lok is a trademark of U.S. Pipe and Foundry Company, used with permission.

Rev. 7-19

- Catalog number
A-2362-37 radial compression ends
- Sizes – 2", 2-1/2", 3", 4", 6", 8"
- Meets or exceeds all applicable requirements of ANSI/AWWA C509, UL 262 Listed, FM 1120/1130 Approved, and certified to ANSI/NSF 61 & 372
- Radial compression ends fit IPS PVC plastic pipe
- Ductile Iron body with nominal 10 mils Pro-Gard® Fusion Bonded Epoxy Coated interior and exterior surfaces
- Epoxy coating meets or exceeds all applicable requirements of ANSI/AWWA C550 Standard
- Iron wedge, symmetrical and fully encapsulated with molded rubber; no exposed iron
- Non-rising stem (NRS)
- Triple O-ring seal (2 above the thrust collar and 1 below)
- 2" square wrench nut - open left or open right
- 350 psig (2400 kPa/24 barg) maximum working pressure; 700 psig (4800 kPa/48 barg) static test pressure
- UL Listed, FM Approved: 350 psig (2400 kPa/24 barg)
- Designed for potable water applications



A-2362-37 shown

Options

See page 10.54 for more information on Resilient Wedge Gate Valve options

- Position indicators
- Handwheel
- Low zinc, silicon bronze ASTM B98-C66100/H02 stem
- EPDM DISC and O-rings

Resilient wedge gate valve parts

Catalog Part Number	Description	Material	Material Standard
G-16	Bonnet bolts and nuts	Stainless steel	Type 316
G-41	Stuffing box bolts and nuts	Stainless steel	Type 316
G-49	Stem O-rings (3)	Nitrile	ASTM D2000
G-200	Wrench nut cap screw	Stainless steel	Type 316
G-201	Stuffing box with dirt seal ++	Ductile iron** Nitrile	ASTM A536 ▼ ASTM D2000
G-202	Wrench nut	Ductile iron	ASTM A536 ▼
G-203	Stem	Bronze	ASTM B138
G-204	Handwheel (not shown)	Cast iron +	ASTM A126 CL.B
G-205	Stem nut	Bronze	ASTM B584
G-206	Guide cap bearings	Acetal	-
G-208	Anti-friction washers (2)	Acetal	-
G-209	Wedge Rubber Encapsulation	Ductile iron * SBR	ASTM A536 ▼ -
G-210**	Bonnet	Ductile iron	ASTM A536 ▼
G-211**	Bonnet O-ring +++	Nitrile	ASTM D2000
G-212**	Body	Ductile iron	ASTM A536 ▼

*Fully encapsulated in molded rubber with no iron exposed;

▼ Material strength ASTM A536 65-45 minimum

+ Manufacturer's option to upgrade material to ductile iron ASTM A536

+++ 2"-3" valves use a bonnet gasket

++ Dirt seal on 2 1/2 -8" valves

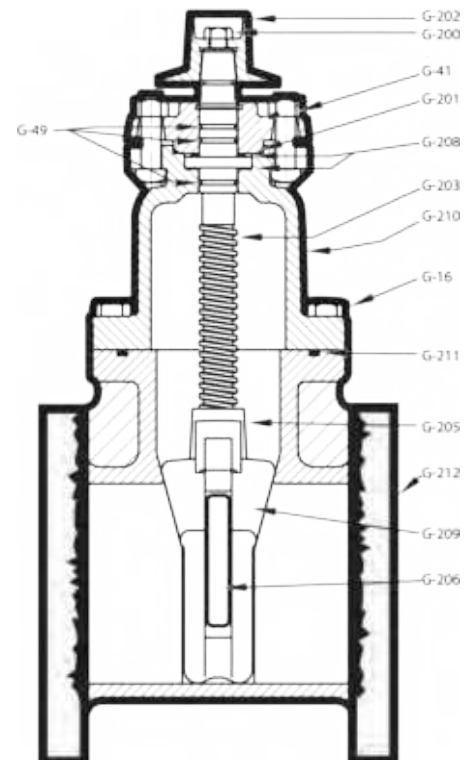

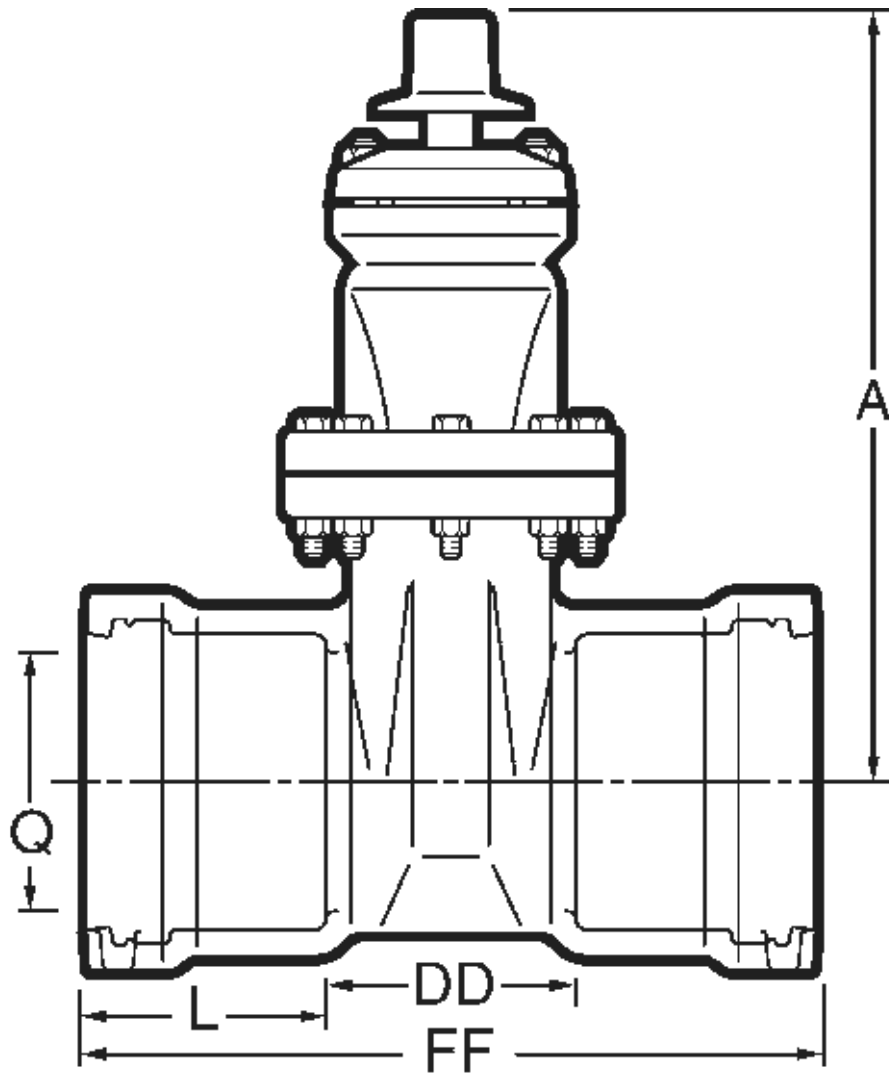

Dimensions

Dimension*	Nominal Size					
	2"	2-1/2"	3"	4"	6"	8"
A	9.88	12.38	12.38	14.19	19.00	21.50
FF	10.25	10.75	11.75	13.43	15.91	18.40
L	3.50	3.69	4.12	4.46	5.46	6.20
Q (bore)	2.30	2.80	3.30	4.30	6.30	8.30
DD	3.25	3.37	3.51	4.51	4.99	6.00
Turns to open	8	11	11	14	20.5	26.5
Weight*	35	65	67	96	155	260
Closing Torque (FT-LBS), Non-Geared	20	28	52	75	110	150
Closing Torque (FT-LBS), Bevel	N/A	N/A	31	44	65	88
Closing Torque (FT-LBS), Spur	N/A	N/A	N/A	41	60	82

*All dimensions are in inches. All weights are in pounds and are approximate.

Rev. 7-19

- Catalog number
A-2362-8 threaded ends
- Sizes – 2", 2-1/2", 3"
- Meets or exceeds all applicable requirements of ANSI/AWWA C509 Standard, UL 262 Listed, FM 1120/1130 Approved, and certified to ANSI/NSF 61 & 372
- Threaded end dimensions comply with ANSI B2.1
- Iron body with nominal 10 mils Mueller Pro-Gard™ Fusion Bonded Epoxy Coated interior and exterior surfaces
- Epoxy coating meets or exceeds all applicable requirements of ANSI/AWWA C550 Standard
- Iron wedge, symmetrical and fully encapsulated with molded rubber; no exposed iron
- Non-rising stem (NRS)
- Triple O-ring seal (2 above the thrust collar and 1 below)
- 2" square wrench nut - open left or open right
- 350 psig (2400 kPa/24 barg) maximum working pressure; 700 psig (4000 kPa/48 barg) static test pressure
- 2-1/2"-3" size – UL Listed, FM Approved: 350 psig (2400 kPa/24 barg)
- Designed for potable water applications



Handwheel

A-2362-8 shown

Options

See page 10.54 for more information on Resilient Wedge Gate Valve options

- Position indicators
- Low zinc, silicon bronze ASTM B98-C66100/H02 stem
- Handwheel
- EPDM DISC and O-rings

Resilient wedge gate valve parts

Catalog Part Number	Description	Material	Material Standard
G-16	Bonnet bolts and nuts	Stainless steel	Type 316
G-41	Stuffing box bolts and nuts	Stainless steel	Type 316
G-49	Stem O-rings (3)	Nitrile	ASTM D2000
G-200	Wrench nut cap screw	Stainless steel	Type 316
G-201	Stuffing box with dirt seal*	Ductile iron Nitrile	ASTM A536 ▼ ASTM D2000
G-202	Wrench nut	Ductile iron	ASTM A536 ▼
G-203	Stem	Bronze	ASTM B138
G-204	Handwheel (not shown)	Cast iron	ASTM A126 CL.B
G-205	Stem nut	Bronze	ASTM B584
G-206	Guide cap bearings	Acetal	-
G-207	Stuffing box	Ductile iron	ASTM A536 ▼
G-208	Anti-friction washers (2)	Acetal	-
G-209	Wedge Rubber Encapsulation	Ductile iron SBR	ASTM A536 ▼ -
G-210	Bonnet	Ductile iron	ASTM A536 ▼
G-211	Bonnet gasket	Nitrile	ASTM D2000
G-212	Body	Ductile iron	ASTM A536 ▼

* Fully encapsulated in molded rubber with no iron exposed

▼ Material strength ASTM A536 65-45 minimum

*Dirt seal on 2 1/2 - 3" valves

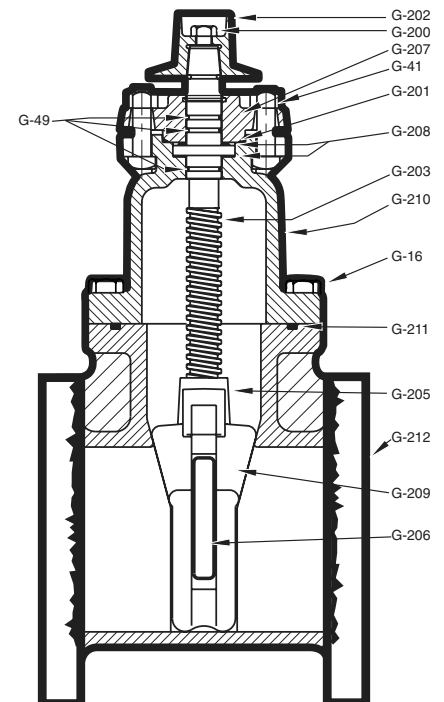

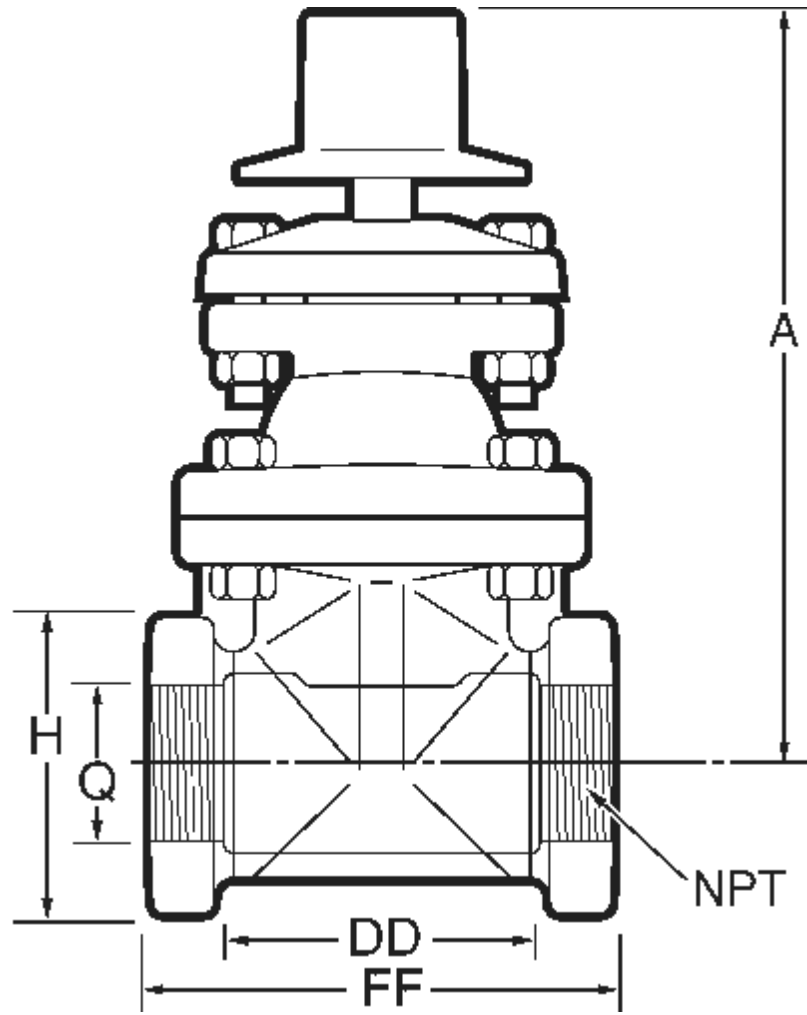

Dimensions

Dimension*	Nominal Size		
	2"	2-1/2"	3"
A	9.88	12.38	12.38
FF	5.88	5.88	6.88
Q (bore)	2.30	2.80	3.30
H (hex across flats)	3.88	4.25	5.00
DD	4.12	4.12	5.12
Turns to open	8	11	11
Weight*	31	60	62
Closing Torque (FT-LBS), Non-Geared	20	28	52
Closing Torque (FT-LBS), Bevel	N/A	N/A	31
Closing Torque (FT-LBS), Spur	N/A	N/A	N/A

*All dimensions are in inches. All weights are in pounds and are approximate.

Rev. 3-18

- Catalog number
A-2380-6 flanged ends
- Sizes – 14", 16", 18", 20", 24", 30", 36"
- Meets or exceeds all applicable requirements of ANSI/AWWA C500 Standard
- Flange ends comply with ASME/ANSI B16.1 Class 125
- Iron body - bronze mounted
- Double disc parallel seat with four point wedging mechanism
- Non-rising stem (NRS)
- O-ring sealed stuffing box
- With handwheel - open left or open right
- 150 psig (1000 kPa/10 barg) maximum working pressure; 300 psig (2100 kPa/21 barg) test pressure
- Designed for potable water applications



A-2380-6 shown

Options

See pages 10.54 for more information on Gate Valve options.

- Low zinc, silicon bronze ASTM B98-C66100/H02 stem and disc pins ASTM B763-C99500 Stem 18" - 36"
- Bevel gearing; 16"-36"
- Spur gearing; 16"-36"
- Roller, track, scrapers; 16" - 36"
- Position indicators (14"-16" only)
- NRS by-pass valve; 16"-36"
- 2" Square wrench nut
- Epoxy Coating

Double-disc gate valve parts

Catalog Part Number	Description	Material	Material Standard
G-15	Bonnet gasket	Composition	ASTM D1170
G-16	Bonnet Bolts & Nuts	316 Stainless steel	ASTM F593 (bolt) ASTM F594 (nut)
G-18	Seat ring	Bronze	ASTM B62
G-19	Disc and disc ring	Cast Iron*	ASTM A126 CL.B
G-20	Disc pin	Bronze	ASTM B21
G-21	Side spreader	Bronze	ASTM B62
G-22	Bottom wedge	Cast Iron	ASTM A126 CL.B
G-24	Test plug	Iron	-
G-26	Nut for wrench nut	316 Stainless steel	ASTM F594
G-32	Stuffing box gasket	Fiber	-
G-37	Top wedge nut	Cast Iron*	ASTM A126 CL.B
G-38	Wrench nut	Cast Iron	ASTM A126 CL.B
G-41	Stuffing box bolt and nut	316 Stainless steel	ASTM F593 (bolt) ASTM F594 (nut)
G-42	Stem	Bronze	ASTM B138**
G-43	Bonnet	Cast Iron	ASTM A126 CL.B
G-45	Hand wheel	Cast Iron	ASTM A126 CL.B
G-47	Body	Cast Iron	ASTM A126 CL.B
G-48	Stuffing box o-ring	Rubber	ASTM D2000
G-49	Stem o-ring	Rubber	ASTM D2000
G-50	Stuffing box	Cast Iron	ASTM A126 CL.B

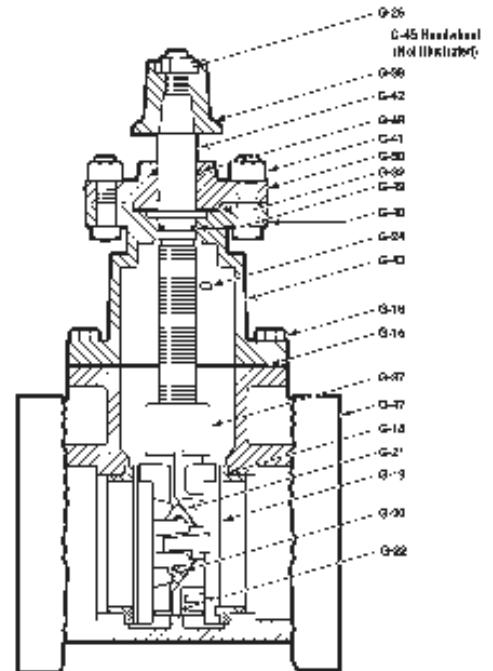

* Cast iron discs with rolled-in bronze facings; cast iron top wedge nut with integrally cast bronze bushing.

**18" - 36" ASTM B584

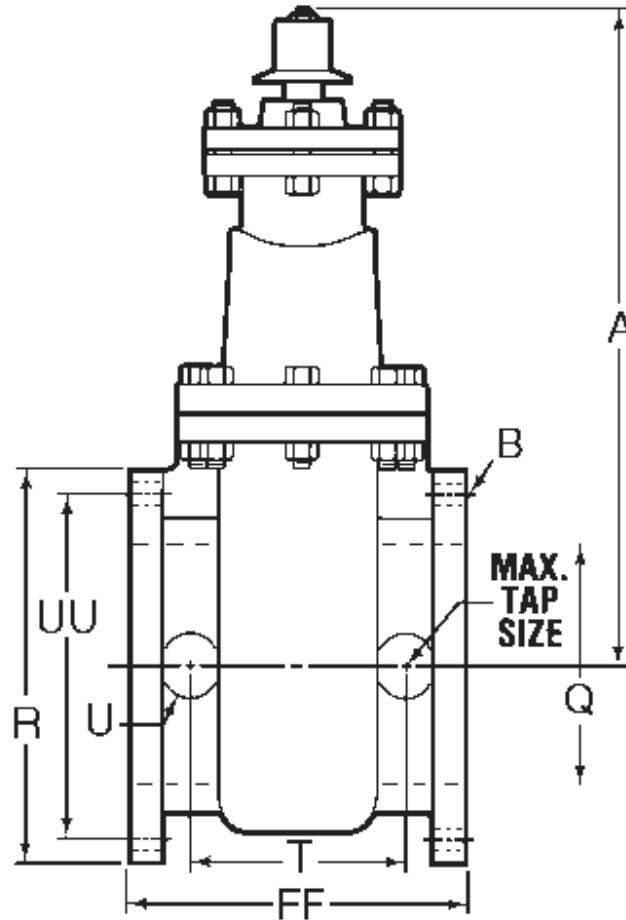

Dimensions

Dimension*	Nominal Size						
	14"	16"	18"	20"	24"	30"	36"
A	34.12	39.00	43.00	47.50	55.75	66.50	**
Q (bore)	14.00	16.00	18.00	20.00	24.00	30.00	36.00
FF	15.00	20.25	22.00	22.25	25.50	28.75	32.00
R	21.00	23.50	25.00	27.50	32.00	38.75	46.00
T	9.00	N/A	N/A	N/A	N/A	N/A	N/A
U	3.00	N/A	N/A	N/A	N/A	N/A	N/A
UU (bolt circle diameter)	18.75	21.25	22.75	25.00	29.50	36.00	42.75
B (number and size of holes)	12-1-1/8	16--1-1/8	16--1-1/4	20--1-1/4	20--1-3/8	28--1-3/8	32--1-5/8
Maximum tap size	2	N/A	N/A	N/A	N/A	N/A	N/A
Turns to open (without gearing)	46	53	59	65	77	67	80
Turns to open (bevel gearing)	NA	212	236	260	308	268	320
Turns to open (spur gearing)	NA	217	242	267	316	268	320
Weight*	747	1156	1439	1775	2943	5189	8061
Closing Torque (FT-LBS), Non-Geared	225	275	275	300	325	N/A	N/A
Closing Torque (FT-LBS), Bevel	66	81	81	88	96	132	162
Closing Torque (FT-LBS), Spur	61	75	75	81	88	122	149

*All dimensions are in inches. All weights are in pounds and are approximate.

**36" valves sold only with gear operators, dimension depends on style of operator selected. Contact Customer Service for Dimension.

Rev. 7-17

- Catalog number
A-2380-16 flanged x mechanical joint (with accessories unassembled)
A-2380-18 flanged x mechanical joint (accessories and bonding set screws in gland unassembled)
A-2380-19 flanged x mechanical joint (less accessories)
- Sizes - 30" & 36"
- Meets or exceeds all applicable requirements of ANSI/AWWA C500 Standard
- Flange ends comply with ASME/ANSI B16.1 Class 125
- Mechanical joint ends comply with ANSI/AWWA C111 Standard
- Iron body - bronze mounted
- Double disc parallel seat with four point wedging mechanism
- Non-rising stem (NRS)
- O-ring sealed stuffing box
- 2" square wrench nut - open left or open right
- 150 psig (1000 kPa/10 barg) maximum working pressure; 300 psig (2100 kPa/21 barg) test pressure
- Designed for potable water applications



A-2380-16 shown

Options

See pages 10.54 for more information on Gate Valve options.

- Low zinc, silicon bronze ASTM B98-C66100/H02 stem and disc pins ASTM B763-C99500 Stem 18" - 36"
- Bevel gearing
- NRS by-pass valve
- Roller, track, scrapers; 16" - 36"
- Handwheel
- Epoxy Coating
- Spur gearing

Double-disc gate valve parts

Catalog Part Number	Description	Material	Material Standard
G-15	Bonnet gasket	Composition	ASTM D1170
G-16	Bonnet Bolts & Nuts	316 Stainless steel	ASTM F593 (bolt) ASTM F594 (nut)
G-18	Seat ring	Bronze	ASTM B62
G-19	Disc and disc ring	Cast Iron*	ASTM A126 CL.B
G-20	Disc pin	Bronze	ASTM B21
G-21	Side spreader	Bronze	ASTM B62
G-22	Bottom wedge	Cast Iron	ASTM A126 CL.B
G-24	Test plug	316 Stainless steel	-
G-26	Nut for wrench nut	316 Stainless steel	ASTM F594
G-32	Stuffing box gasket	Fiber	-
G-37	Top wedge nut	Cast Iron*	ASTM A126 CL.B
G-38	Wrench nut	Cast Iron	ASTM A126 CL.B
G-41	Stuffing box bolt and nut	316 Stainless steel	ASTM F593 (bolt) ASTM F594 (nut)
G-42	Stem	Bronze	ASTM B584
G-43	Bonnet	Cast Iron	ASTM A126 CL.B
G-45	Hand wheel	Cast Iron	ASTM A126 CL.B
G-47	Body	Cast Iron	ASTM A126 CL.B
G-48	Stuffing box o-ring	Rubber	ASTM D2000
G-49	Stem o-ring	Rubber	ASTM D2000
G-50	Stuffing box	Cast Iron	ASTM A126 CL.B

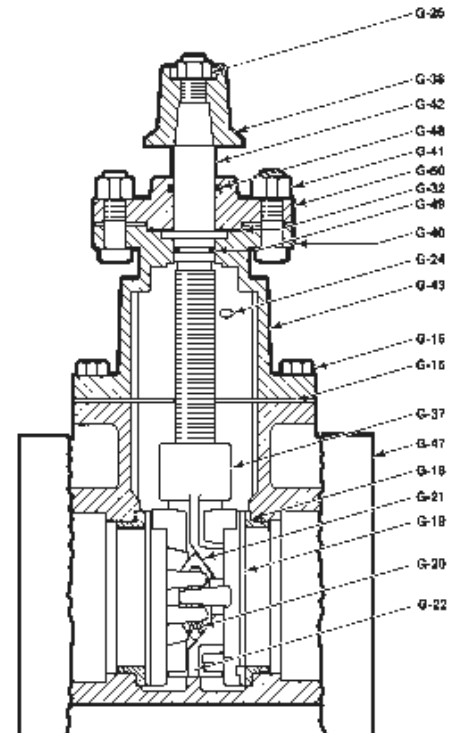

** Cast iron discs with rolled-in bronze facings; cast iron top wedge nut with integrally cast bronze bushing.

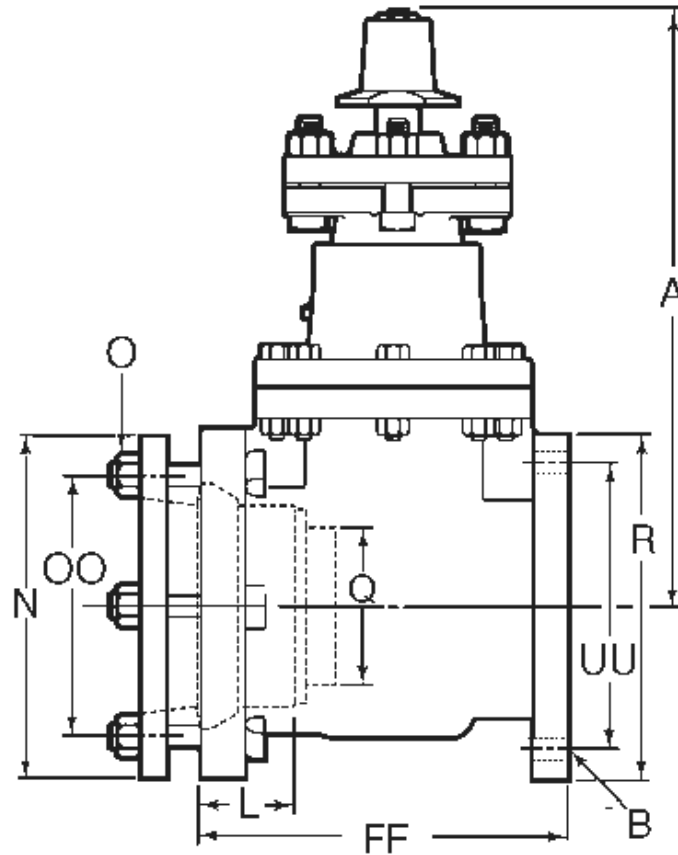

Dimensions

Dimension	Nominal Size	
	30"	36"
A	66.50	**
L	4.00	4.00
N	39.12	46.00
OO (bolt circle diameter)	36.88	43.75
Q (bore)	30.00	36.00
R	38.75	46.00
UU	36.00	42.75
XX	24.38	27.50
FF	28.38	31.50
B (number and size of holes for FL)	28-1-3/8	32-1-5/8
O (number and size of holes for MJ)	20-1-1/8	24-1-1/8
Turns to open (without gearing)	65	78
Turns to open (bevel gearing)	268	320
Turns to open (spur gearing)	268	320
Weight*	5100	8300
Closing Torque (FT-LBS), Non-Geared	N/A	N/A
Closing Torque (FT-LBS), Bevel	132	162
Closing Torque (FT-LBS), Spur	122	149

*All dimensions are in inches. All weights are in pounds and are approximate.

**36" valves sold only with gear operators, dimension depends on style of operator selected. Contact Customer Service for Dimension.

Rev. 3-18

- Catalog number
A-2380-20 standard mechanical joint ends (with accessories unassembled)
A-2380-23 standard mechanical joint ends (less accessories)
- Sizes - 14", 16", 18", 20", 24", 30", 36"
- Meets or exceeds all applicable requirements of ANSI/AWWA C500 Standard
- Mechanical joint ends comply with ASME/ANSI/AWWA C111 Standard
- Iron body - bronze mounted
- Double disc parallel seat with four point wedging mechanism
- Non-rising stem (NRS)
- O-ring sealed stuffing box
- 2" square wrench nut - open left or open right
- 150 psig (1000 kPa/10 barg) maximum working pressure; 300 psig (2100 kPa/21 barg) test pressure
- Designed for potable water applications



A-2380-20 shown

Options

See pages 10.54 for more information on Gate Valve options.

- Low zinc, silicon bronze ASTM B98-C66100/H02 stem and disc pins ASTM B763-C99500 Stem 18" - 36"
- Bevel gearing; 16"-36"
- NRS by-pass valve; 16"-36"
- Spur gearing; 16"-36"
- Roller, track, scrapers; 16" - 36"
- Handwheel
- Position indicators (14" - 16" only)
- Epoxy Coating

Double-disc gate valve parts

Catalog Part Number	Description	Material	Material Standard
G-15	Bonnet gasket	Composition	ASTM D1170
G-16	Bonnet Bolts & Nuts	316 Stainless steel	ASTM F593 (bolt) ASTM F594 (nut)
G-18	Seat ring	Bronze	ASTM B62
G-19	Disc and disc ring	Cast Iron*	ASTM A126 CL.B
G-20	Disc pin	Bronze	ASTM B21
G-21	Side spreader	Bronze	ASTM B62
G-22	Bottom wedge	Cast Iron	ASTM A126 CL.B
G-24	Test plug	316 Stainless steel	-
G-26	Nut for wrench nut	316 Stainless steel	ASTM F594
G-32	Stuffing box gasket	Fiber	-
G-37	Top wedge nut	Cast Iron*	ASTM A126 CL.B
G-38	Wrench nut	Cast Iron	ASTM A126 CL.B
G-41	Stuffing box bolt and nut	316 Stainless steel	ASTM F593 (bolt) ASTM F594 (nut)
G-42	Stem	Bronze	ASTM B138***
G-43	Bonnet	Cast Iron	ASTM A126 CL.B
G-45	Hand wheel	Cast Iron	ASTM A126 CL.B
G-47	Body	Cast Iron	ASTM A126 CL.B
G-48	Stuffing box o-ring	Rubber	ASTM D2000
G-49	Stem o-ring	Rubber	ASTM D2000
G-50	Stuffing box	Cast Iron	ASTM A126 CL.B

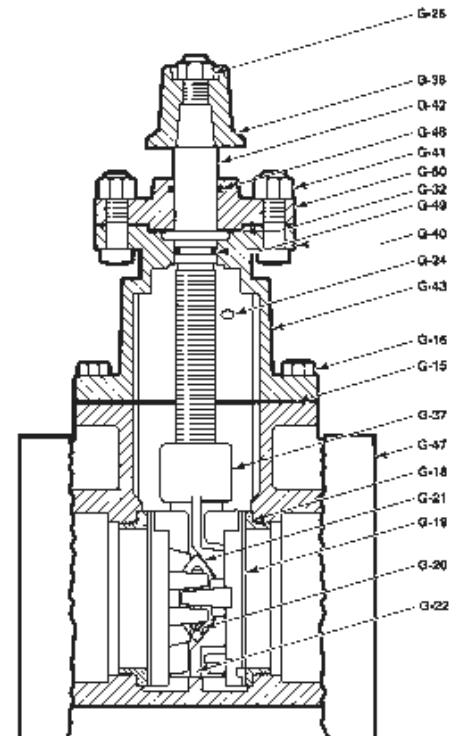

** Cast iron discs with rolled-in bronze facings; cast iron top wedge nut with integrally cast bronze bushing.

***18" - 36" ASTM B583

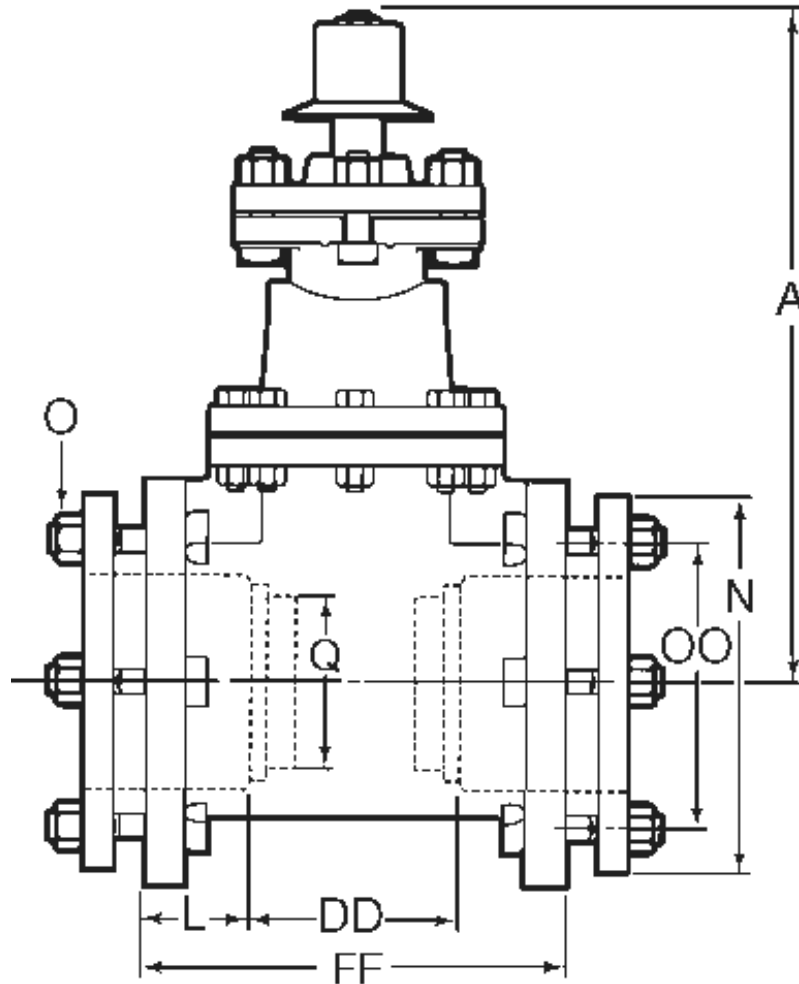

Dimensions

Dimension*	Nominal Size						
	14"	16"	18"	20"	24"	30"	36"
A	34.12	39.00	43.00	47.50	55.75	66.50	**
FF	15.00	19.75	21.00	21.50	23.50	28.00	31.00
L	3.50	3.50	3.50	3.50	3.50	4.00	4.00
N	20.31	22.56	24.83	27.08	31.58	39.12	46.00
O (number and size of holes)	10--7/8	12--7/8	12--7/8	14--7/8	16--7/8	20--1-1/8	24--1-1/8
DD	8.00	12.75	14.00	14.50	16.50	20.00	23.00
Q (bore)	14.00	16.00	18.00	20.00	24.00	30.00	36.00
OO (bolt circle diameter)	18.75	21.00	23.25	25.50	30.00	36.88	43.75
Turns to open (without gearing)	46	53	59	65	77	67	80
Turns to open (bevel gearing)	NA	212	236	260	308	268	320
Turns to open (spur gearing)	NA	217	242	267	316	268	320
Weight*	805	1108	1488	1810	2605	5100	8300
Closing Torque (FT-LBS), Non-Geared	225	275	275	300	325	N/A	N/A
Closing Torque (FT-LBS), Bevel	66	81	81	88	96	132	162
Closing Torque (FT-LBS), Spur	61	75	75	81	88	122	149

Rev. 2-18

Resilient Wedge Options

Clean out Port Option on 16"-54" RWGV

Cleanout port option is available for 16"- 54" resilient wedge gate valves. 16" valves would utilize a 1" port, 18"-24" a 1-1/2" port, while 30"-54" valves utilize a 2" port. Please refer to option 202 (ex. 240A236106LN202) when ordering.



Resilient Wedge and Double-Disc Gate Valve Options

Needle and Slot (Universal) Position Indicator

Can be furnished on 4" and larger non-rising stem valves with or without gearing. Mechanism is fully enclosed and uses a moving pointer on a scale to show relative position of valve gate.

N.R.S. Bypass

Bypass valves are AWWA non-rising stem type. On resilient wedge valves, the bypass valve is also the RW type. On double-disc valves, it is the DD type. Bevel geared or horizontally installed valves have the bypass mounted on the bottom end of the valve. Spur geared or vertically installed valves have the bypass mounted on the disc of the valve body.



Available on 16"-54" Gate Valves Only.

Valve size/type	Bypass valve size
16" RW, FLxFL, MJxMJ, FLxMJ, end types only	2"
18"-20" RW	2"
24" RW	2-1/2"
30", 36" RW	3"
42"-54" RW	4"
16"-20" DD	3"
24", 30" DD	4"
36"	6"

Gearing



Spur Gearing



Bevel Gearing

Non-rising stem gate valves 4" and larger can be furnished with bevel or spur gearing. Gearing is recommended for all resilient wedge gate valves 30" and larger, and for all double-disc gate valves 24" and larger. Gearing provides an additional bearing to support the extreme end of the valve stem. All gears have machine cut teeth. Bevel geared valves are for horizontal installation and spur geared valves for vertical. Styles shown are typical – actual appearance may vary.

2" Square Wrench Nut or Handwheel

The 2" square wrench nut is standard on all N.R.S. resilient wedge and double-disc gate valves except flange x flange and thread x thread valves, which have a handwheel as standard. The wrench nut and handwheel are optional alternatives to these standard features.

How to order

Accessories are ordered by adding a suffix number to the basic gate valve catalog number. See chart below for accessory suffix numbers.

Catalog number for options*

Catalog number suffix		Description	Valve size
Without indicator	With indicator		
02	102	Bevel gearing	4" and larger
03	103	Spur gearing	4" and larger
06	106	Bevel gearing and bypass	16"-54"
07	107	Spur gearing and bypass	16"-54"
09	-	Bypass only	16"-24"
-	108	Position indicator only	4"-24"

*Fasteners, coatings, operators and other options not included in this chart are ordered by including them in the valve specification notations.

Double-Disc Gate Valve Options

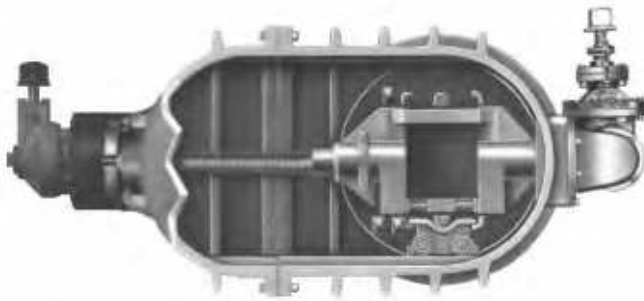

**Rollers, Tracks and Scrapers
(Double-disc gate valves only)**

Double-disc gate valves in sizes 16" through 36" for vertical installations are furnished with a shoe on each side of the disc assembly for guiding the disc assembly throughout its entire travel. Gate valves in sizes 16" through 36" for horizontal installations are furnished with rollers which travel on a bronze track in the body and bonnet. These rollers support the weight of the disc assembly throughout its entire travel. The roller carriage has scrapers for cleaning the track ahead of the rollers. Rollers and tracks are required on 16" and larger double-disc gate valves when the main valve stem is horizontal. They are not required on bevel geared valves specified for vertical installation.

Double disc gate valve o-ring conversion kit

Mueller Co. offers kits to convert non-rising stem conventionally packed gate valves to O-ring sealed type. The conversion replaces the conventional packing with two O-ring seals above the thrust collar and a gasket seal between the bonnet and new stuffing box.



O-ring conversion kit contains the following

- (1) G-70 Stuffing box
- (2) G-48 O-rings
- (1) G-32 Stuffing box gasket
- G-41 bolts and nuts
 - (2) for 2" valve
 - (4) for 3"-14" valves
 - (6) for 16"-24" valves

Valve Size	Conversion Kit Part Number
2"	181338
3"	181393*
4"	181340
6"	181341
8"	181342
10"	181343
12"	181344
14"	181388
16"	181389
18"	181390
20"	181391
24"	181392

*1956 Design. For valves made prior to 1956 use kit number 181339

Accessory Kits

Type	Part Number	Sizes*	Included
Flange end	A-199206	4"-12"	Flat gasket, bolts/nuts
MJ end - D.I.	A-199000	2", 3"-48"	Ring gasket, DI gland, bolts/nuts
MJ end - C.I.	A-199100	2", 3"-24"	Ring gasket, CI gland, bolts/nuts

NOTE: Basic kits listed here. Contact MUELLER Customer Service Center regarding the many options available.

Slip - on Gaskets

Valve Size	Part Number
4"	195204
6"	195205
8"	195206
10"	195207
12"	195208
14"	348510
16"	199946

Gland Packs

Standard Mechanical Joint Accessories

Valve Size	Standard Mechanical Joint Gland Part Number	Plain Rubber Gasket Part Number
2"	155163-1	194629
3"	240021-1	194531
4"	240022-1	194532
6"	155016-1	194533
8"	240023-1	194534
10"	240024-1	194535
12"	240025-1	194536
14"	155273-1	194684
16"	155170-1	194632
18"	155352-1	194729
20"	155264-1	194670
24"	155263-1	194671
30"	155481-1	194779
36"	155079-1	194169

Radial Compression Gaskets

Valve Size	Part Number
2"	195290
2-1/2"	195291
3"	195292
4"	195293
6"	195294
8"	348375

"T" Head Bolts and Nuts (size supplied will be appropriate for size of valve) - specify quantity

Valve Size	Part Number
2"	280035
3"	280036
4"	280037
4"	280042**
6"	280037
6"	200042**
8"	280038
8"	200043**
10"	280038
10"	280043**
12"	280038
12"	280043**
14"	280038
16"	280039
18"	280039
20"	280039
24"	280040
30"	280041
36"	280041

* Nominal
** Anti-rotation bolts

Gland Packs

D-150 Mechanical Joint Accessories

Valve Size	D-150 Mechanical Gland Joint Part Number	D-150 Mechanical Joint Gland with Bonding Screws Part Number	D-150 Plain Gasket Part Number	D-150 Duck-tipped Gasket Part Number
4"	160519	186610	194738	194732
6"	160520	186611	194739	194733
8"	160521	186612	194740	194734
10"	160522	186613	194741	194735
12"	160523	186614	194742	194736

To order Gate Valves specify:

Quantity

If more than one size, specify quantity of each

Size

Nominal size of valve

Catalog number

Special catalog number suffix

See chart at bottom of page 10.54 if gearing, grease cases, bypass valves or position indicators are required. The appropriate suffix number is added to the base catalog number.

Direction of opening

Specify open left (counter-clockwise) or open right (clockwise). Wrench nuts on valves that open to the right are painted red for identification purposes.

Method of operation

N.R.S. valves are available with either a 2" square wrench nut or a handwheel. Handwheels are standard on flanged x flanged and thread x thread valves; all other NRS* valves have a 2" square wrench nut as standard. Outside screw and yoke type valves are available with handwheel only. When ordering NRS valves, specify wrench nut or handwheel.

* 30"-54" resilient wedge and double-disc gate valves must be ordered with actuator.

Special Requirements

Contact Mueller Customer Service Center with special requirements such as special paints or coatings, low zinc bronze stems, stainless steel fasteners etc.

Gate Valve Repair Parts

To order repair parts specify size of valve, direction of opening, year date on body, part number, catalog number of valve if known, and type of ends if ordering body.

Resilient seat valve parts

Catalog Part Number	Description	Material	Material Standard
G-1	Cap nut	Bronze	ASTM B62
G-2	Key	Steel	-
G-3	Handwheel	Cast Iron	ASTM A126 CL.B
G-4	Washer	Brass	-
G-5	Bush nut	Bronze	ASTM B62
G-7	Gland nut	Bronze	ASTM B21 Alloy 464
G-9	Gland	Bronze	ASTM B62
G-10	Gland bolt	Steel	ANSI B18.2.1
G-11	Yoke bolt and nut	Steel	ANSI B18.2.1
G-16	Bonnet bolts & nuts	Steel	ANSI B18 2.1 plated
G-23	Stem packing	Lubricated flax	-
G-24	Test plug	Iron	-
G-26	Nut for wrench nut	Steel	ANSI B18 2.1 plated
G-32	Stuffing box gasket	Fiber	-
G-38	Wrench nut	Cast Iron	ASTM A126 CL.B
G-41	Stuffing box bolt and nut	Steel	ANSI B18 2.1 plated
G-42	Stem	Bronze	ASTM B138
G-45	Handwheel	Cast Iron	ASTM A126 CL.B
G-48	Stuffing box o-ring	Rubber	ASTM D2000
G-49	Stem o-ring	Rubber	ASTM D2000
G-176	Anti-friction washer	Acetal	-
G-178	Seat ring	Rubber	ASTM D2000
G-179	Retaining screw	Stainless Steel	-
G-181	Bonnet gasket	Composition	ASTM D1170
G-183	Stem	Bronze	CDA Alloy 676
G-184	Pin	Bronze	-

