

Block Cylinders

for stroke end control

double acting, max. operating pressure 500 bar

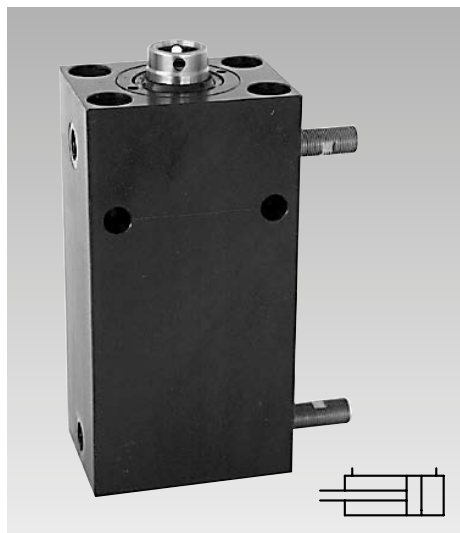

Fixing possibilities

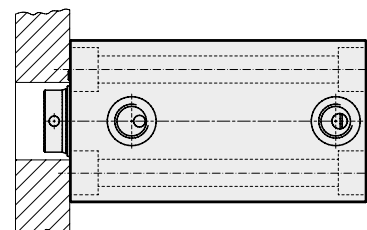
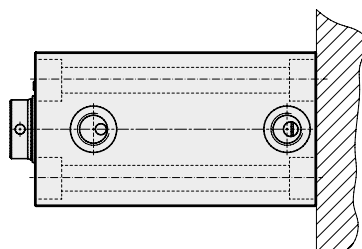
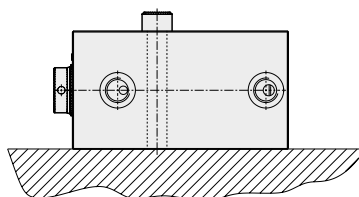

Cylinders must be backed up for operating pressures exceeding 100 bar

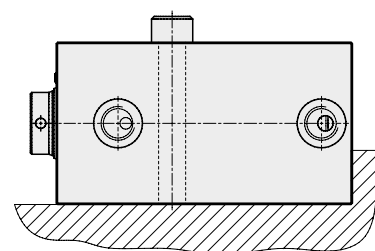

Application

Double-acting block cylinders with stroke end control are particularly suitable for automated installations, time and cycle-dependent clamping and unclamping.

Description

The stroke end control supplies the required information about the position of the piston. Control is made by pressure-proof sensors, which are fixed at the corresponding stroke end of the cylinder piston in the body.

Advantages

- Compact design
- Same dimensions as the block cylinders as per data sheet B 1.5094, except for total length
- Diverse mounting possibilities
- 3 standard stroke lengths
- Sensors can be mounted at the right or left-hand side
- Switching point of the sensors adjustable up to 4 mm before the final position
- All versions are equipped by default with FKM seals

Important notes!

The high-pressure resistant sensors are installed on customer site, in order to avoid transport damages. Please refer to the installation instructions on page 4. Maximum environmental temperature according to the sensor -25...+80°C or 120°C.

Version with pipe thread

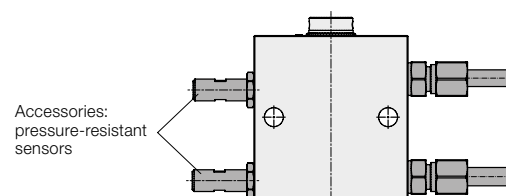

Version for manifold mounting with O-ring sealing

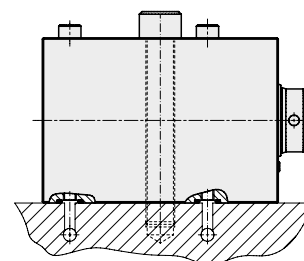

Version for manifold mounting with O-ring sealing bottom side

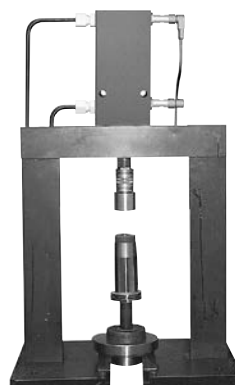
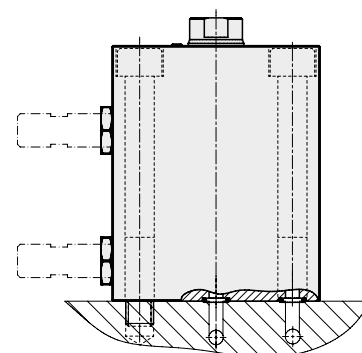

Application example

Application for pressing in of piston rods into the pistons.

To monitor the press-in depth of the piston rods, the stroke ends of the block cylinder are controlled.

Technical data

Dimensions – Versions with pipe thread

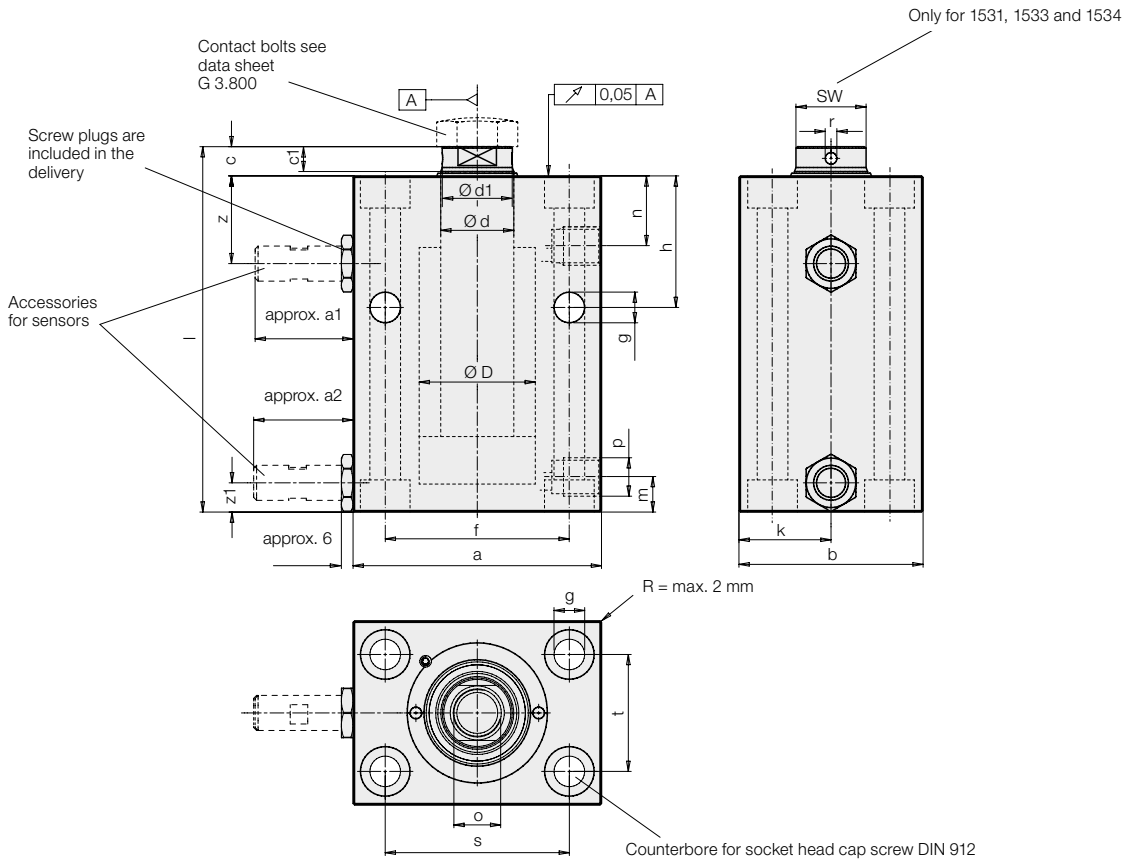

Oil supply and O-ring sealing at:

**Broad side
Version K
16 - 40 stroke**

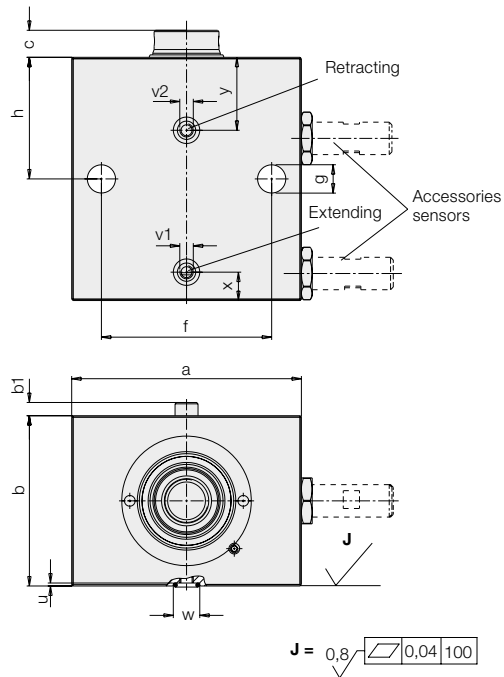

**Broad side
Version K
from 50 stroke**

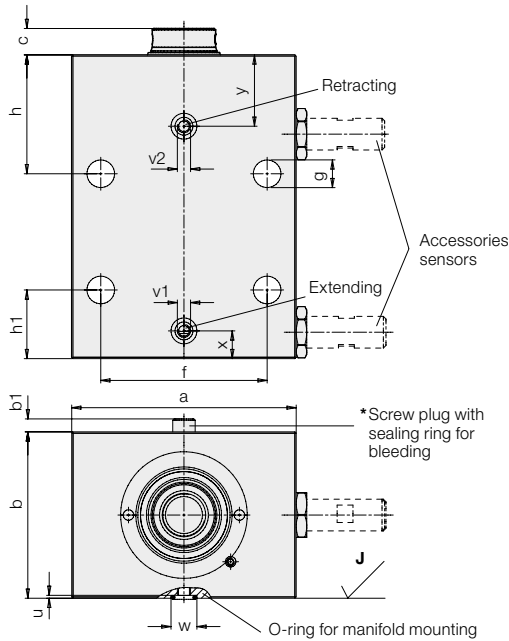

**Bottom side
Version B**

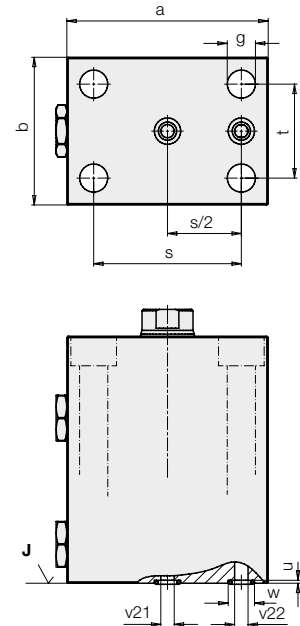

* For use of the sensors at the left side, the cylinder will be rotated by 180° and the plug with sealing ring and the O-ring for manifold mounting are exchanged.

Dimensions

Piston Ø D		[mm]	16	25	32	40	50	63	80	100
Rod Ø d		[mm]	10	16	20	25	32	40	50	63
Push force at	100 bar	[kN]	2	4.9	8	12.6	19.5	31.2	50.4	78.4
	500 bar	[kN]	10	24.5	40.2	62.8	98.5	156	252	392
Pull force at	100 bar	[kN]	1.2	2.9	4.9	7.7	11.6	18.6	30.6	47.4
	500 bar	[kN]	6.1	14.5	24.5	38.3	57.9	93	153.2	236.8
Oil volume/	Stroke to extend	[cm ³]	2.01	4.91	8.05	12.56	19.63	31.17	50.26	78.54
10 mm stroke	Stroke to retract		1.2	2.9	4.9	7.7	11.6	18.6	30.6	47.4
a		[mm]	60	65	75	85	100	125	160	200
a1		[mm]	35	34.5	33.5	33.5	30	47	37	42
a2		[mm]	35	34.5	33.5	34	32	47	39	44
b		[mm]	35	45	55	63	75	95	120	150
b1		[mm]	4	5	5	5	6	5.5	7.5	7.5
c		[mm]	6	7	10	10	10	14	14	15
Ø d1 x c1		[mm]	9,2x3.7	15x5	19x7.8	24x7.1	30,5x6.4	38,7x9.2	48x9.2	61x10.7
f		[mm]	30	50	55	63	76	95	120	158
g		[mm]	6.5	8.5	10.5	10.5	13	17	21	25
h		[mm]	40	38	45	45	49	52	62	64
h1		[mm]	24	38	29	26	33	37	47	52
k		[mm]	17.5	22.5	27.5	31.5	37.5	47.5	60	75
m		[mm]	11	16	13	12	13	20.5	20	24
n		[mm]	16.5	18	24	24	27	26	34	35
o x depth of thread		[mm]	M6x12	M10x15	M12x15	M16x25	M20x30	M27x40	M30x40	M42x60
p			G 1/4	G 1/4	G 1/4	G 1/4	G 1/4	G 1/2	G 1/2	G 1/2
r		[mm]	-	-	-	4	4	4	5	6
s		[mm]	40	50	55	63	76	95	120	158
t		[mm]	22	30	35	40	45	65	80	108
u ± 0.05		[mm]	1.1	1.1	1.1	1.1	1.1	1.5	1.5	1.5
v1 extend		[mm]	M4	M5	M5	M5	M6	M6	M8	M8
v2 retract		[mm]	M4	M5	M5	M5	M6	M6	M8	M8
v21 extend		[mm]	3.5	4	5	6	6	8	8	8
v22 retract		[mm]	3.5	4	5	6	6	8	8	8
w +0.2		[mm]	9.8	9.8	9.8	9.8	10.8	13.8	13.8	13.8
x		[mm]	9	16	13	10.5	13	18	22.5	24
y		[mm]	20.5	21	27	27	29.5	31.5	39	40
z		[mm]	28	24.5	30.5	30	33	34.5	41.5	42.5
z1		[mm]	11	12.7	14.5	13	17.5	21	26	30
R		[mm]	-	-	-	2	2	2	2	-
SW		[mm]	8	13	17	-	-	-	-	-
Dimensions O-ring			7x1.5	7x1.5	7x1.5	7x1.5	8x1.5	10x2	10x2	10x2
Part no. O-ring			3001 077	3001 077	3001 077	3001 077	3000 275	3001 078	3001 078	3001 078
Stroke ±1		[mm]	16	20	25	25	25	30	32	40
Total length l ±1		[mm]	81	88	102	104	109	126	141	156
Weight		[kg]	1	1.6	2.7	3.4	5.1	8.9	16.3	28.2
With pipe thread										
Part no.			1531 136	1533 136	1534 136	1535 136	1536 136	1537 146	1538 146	1539 156
For manifold mounting with O-ring sealing										
Part no. version K			1531 130K	1533 130K	1534 130K	1535 130K	1536 130K	1537 140K	1538 140K	1539 150K
Part no. version B			1531 136B	1533 136B	1534 136B	1535 136B	1536 136B	1537 146B	1538 146B	1539 156B
Stroke ±1		[mm]	50	50	50	50	50	63	80	
Total length l ±1		[mm]	115	118	127	129	134	159	189	
Weight		[kg]	1.7	2.3	3	4.2	6.2	11.1	21.7	
With pipe thread										
Part no.			1531 166	1533 166	1534 166	1535 166	1536 166	1537 176	1538 186	
For manifold mounting with O-ring sealing										
Part no. version L			1531 160L	1533 160L	1534 160L	1535 160L	1536 160L	1537 170L	1538 180L	
Part no. version B			1531 166B	1533 166B	1534 166B	1535 166B	1536 166B	1537 176B	1538 186B	
Stroke ±1		[mm]	100	100	100	100	100	100	100	100
Total length l ±1		[mm]	165	168	177	179	184	196	209	216
Weight		[kg]	2.5	3.3	4.8	6	8.6	14	24.2	39
With pipe thread										
Part no.			1531 196	1533 196	1534 196	1535 196	1536 196	1537 196	1538 196	1539 196
For manifold mounting with O-ring sealing										
Part no. version L			1531 190L	1533 190L	1534 190L	1535 190L	1536 190L	1537 190L	1538 190L	1539 190L
Part no. version B			1531 196B	1533 196B	1534 196B	1535 196B	1536 196B	1537 196B	1538 196B	1539 196B
Accessory sensor										
Part no.			3829 180	3829 180	3829 180	3829 180	3829 180	3829 030	3829 030	3829 204
Accessory pull-type connector pnp										
M12x1 knee-type										
Part no.			3829 049	3829 049	3829 049	3829 049	3829 049	3829 049	3829 049	3829 049
M12x1 straight										
Part no.			3829 078	3829 078	3829 078	3829 078	3829 078	3829 078	3829 078	3829 078

Technical characteristics see page 4

High-pressure resistant sensors

For block cylinders:

1531 XXX
1533 XXX
1534 XXX
1535 XXX
1536 XXX

1537 XXX
1538 XXX

1539 XXX

General and technical characteristics

Environmental temperature	°C	-25...+80	-25...+120	-25...+80	-25...+120	-25...+80
Rated operating distance S _n	mm	1.5	1.5	1.5	1.5	1.5
Secured operating distance S _a	mm	0...1.2	0...1.2	0...1.2	0...1.2	0...1.2
Repeatability	%	≤ 5	≤ 5	≤ 5	≤ 5	≤ 5
Hysteresis	%	≤ 15	≤ 15	≤ 15	≤ 15	≤ 15
Dimensions DxT	mm	M12x1 x 56	M12x1 x 56	M12x1x78	M12x1 x 78	M12x1 x 93
Material of the body		1.4104	1.4104	1.4104	1.4104	1.4104
Material of sensing face		EP (Duroplast)	Ceramics	EP (Duroplast)	Ceramics	EP (Duroplast)
Code class	IP54	68	68	68	68	68
Connection type		Plug S4	Plug S4	Plug S4	Plug S4	Plug S4
Electrical characteristics						
Voltage		DC	DC	DC	DC	DC
Wiring		3 wires	3 wires	3 wires	3 wires	3 wires
Switching function		interlock	interlock	interlock	interlock	interlock
Output signal		npn	npn	npn	npn	npn
Rated operating voltage	V	24 DC	24 DC	24 DC	24 DC	24 DC
Rated operating current	mA	200	200	200	200	200
Operating voltage	V	10...30 DC	10...30 DC	10...30 DC	10...30 DC	10...30 DC
Ripple	%	≤ 15	≤ 15	≤ 15	≤ 15	≤ 15
Switching frequency	Hz	2000	400	1000	400	1000
No-load current	mA	≤ 10/≤ 2	≤ 8	≤ 10/≤ 1	≤ 8	≤ 10/≤ 1
Voltage drop	V	≤ 1.5/-	≤ 2.5	≤ 1.5/-	≤ 2.5	≤ 1.5/-
Short circuit protection		yes	yes	yes	yes	yes
Protection against reverse battery		yes	yes	yes	yes	yes
Part no. sensor (with mounted seals)		3829 180	3829 228	3829 030	3829 227	3829 204

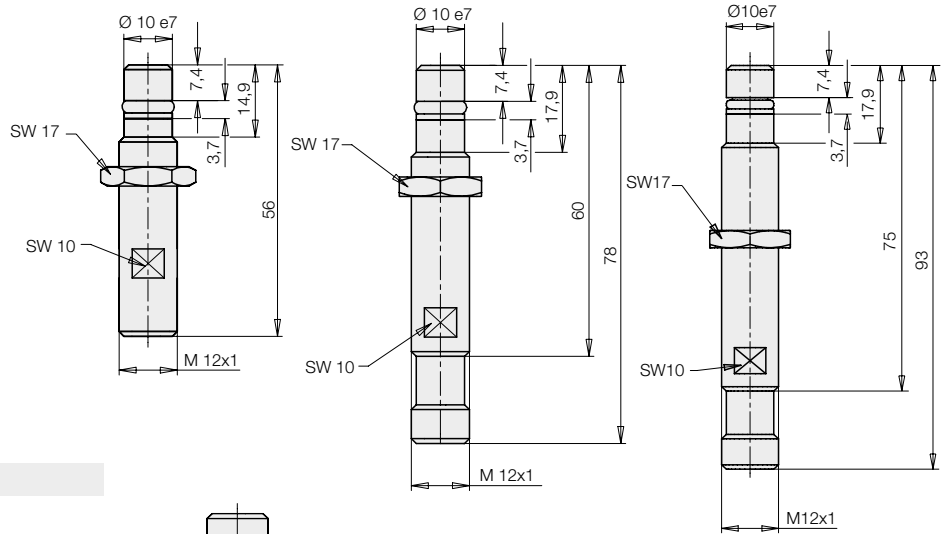
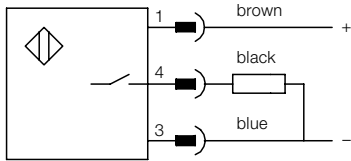

Mounting and setting of the sensors

Front sensor:

- Extend piston rod completely
- Carefully screw in the sensor to the stop at the piston. Turn back the sensor:

Rotation	Switching point before the final position
1/4	approx. 4 mm
1 1/4	approx. 1 mm
- Lock the sensor in this position by means of a nut
- Wire the switch electrically and check the function

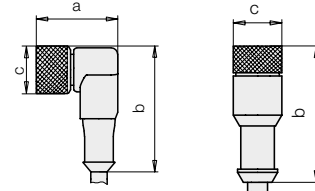
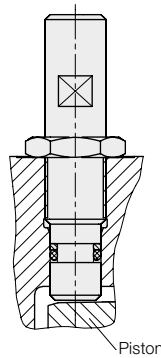

LED: Operating voltage (green)
 Function display (yellow)

Rear sensor:

- Retract completely the piston rod (Further steps see front sensor)

Accessories for sensors

	a	b	c	Cable length [m]	Code class	Environmental temperature	LED	Part no.
Plug-type connector npn M12, knee-type	27	38	14.5	3	IP68	-25...+80 °C	yes	3829049
Plug-type connector npn M12, straight	-	44	14.5	5	IP68	-40...+90 °C	no	3829078
Plug-type connector npn M12, knee-type	27	38	14.5	5	IP68	-20...+105 °C	no	3829230
Plug-type connector npn M12, straight	-	44	14.5	5	IP68	-40...+105 °C	no	3829229