

**SCHIEBEL**

# ab series



**Your Success  
is our Driving Force.**

# heavy duty

special  
voltages  
like 500 VAC

torques  
up to  
300.000 Nm

speed up to  
200 rpm

high temp.  
resistance  
up to +100° C

mechanical  
measurement  
of stroke  
and torque

control  
unit  
up to 22 kW

low temp.  
resistance  
up to -60° C

vibration  
resistant design

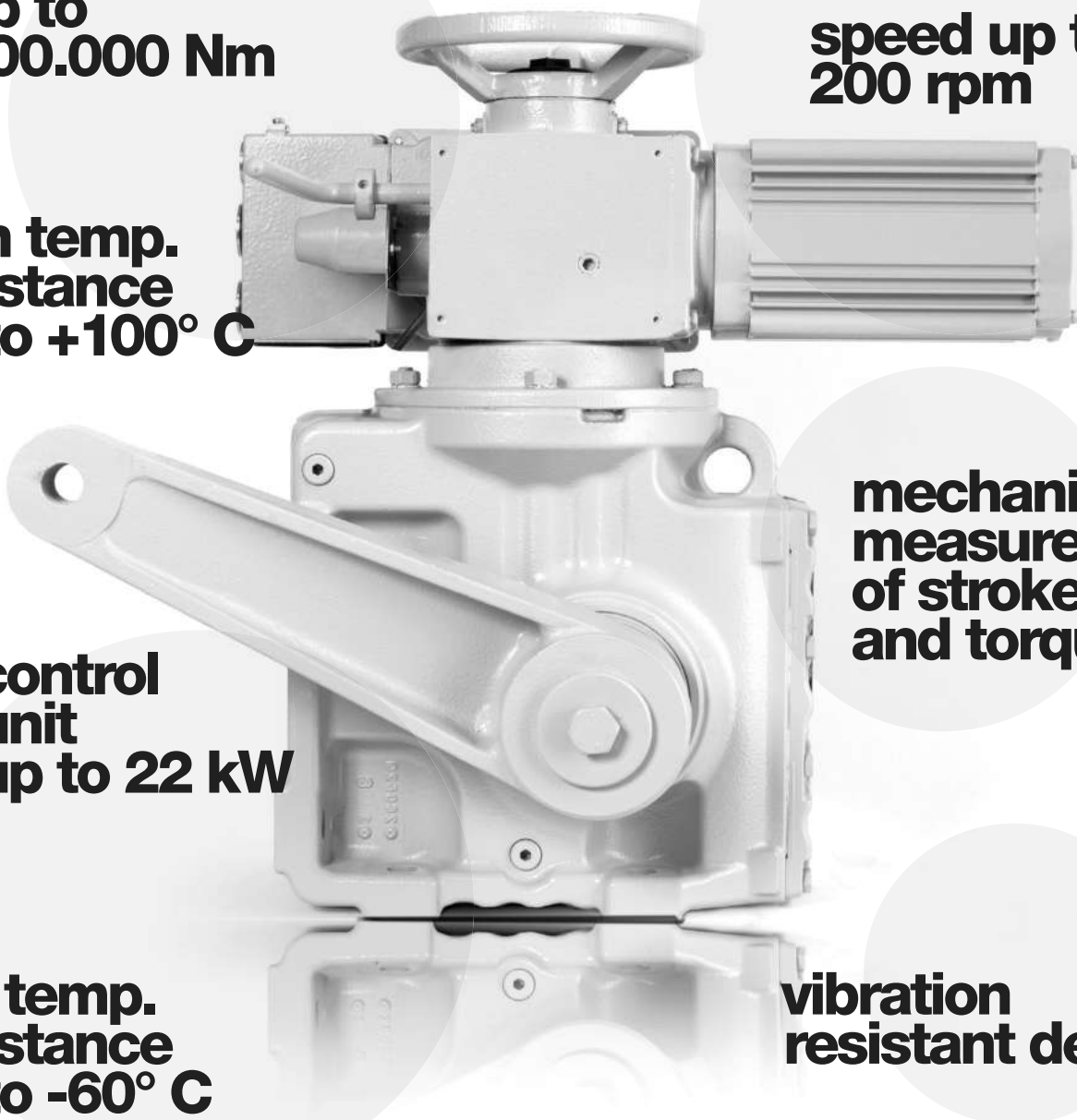

# abseries

## Variety

The ingenious mechanical design opens up a broad variety of functions and options. A failsafe feature can be integrated in the AB actuators at the request of the customer. This guarantees that the actuator is quickly moved to a safe position in emergency situations. Since the safety stroke is triggered mechanically by means of a decoupled spring, it also works in the event of a power failure.

## Robustness

The AB series is constructed intelligently and flexibly to meet any special requirement. The robust and resilient actuator components are amply dimensioned to maximize durability. In designing them, SCHIEBEL paid close attention to providing sufficient space for integrating additional components, so any customer-specific solutions can be implemented trouble-free. Configuration is very straightforward – it is simple to understand and to use.

## Performance

With their durability and reliability, the electrical actuators from the AB series cater to all users looking for strong performance and unsurpassed robustness. The top-quality components manufactured at SCHIEBEL ensure these characteristics and are generously dimensioned to allow very high torque. The configuration is strictly mechanical, so torque is precisely recorded even during control processes. With their enormous power reserves, these actuators can cover a multitude of heavy-duty applications in power station technology, the oil and natural gas industry, the steel industry and many other sectors.

## Safety

For certain applications, inductive proximity switches can be incorporated instead of simple mechanical switches. The actuator can be delivered with an ex-proof controller in a pressure-resistant enclosure, enabling trouble-free use in areas with hydrogen where an IIC gas classification is required under the ATEX directives. Thanks to this and many further options, the AB series actuators can be adapted to meet virtually any customer request. AB actuators attain a safety integrity level of SIL-2; if fitted with the failsafe function, SIL-3. In addition, SCHIEBEL has integrated a direct-acting hand wheel as standard equipment.



**SCHIEBEL**

**the cu**



# Customized solution

## Controller

A special innovation from SCHIEBEL is the concept of the double controller mounted directly on the actuator. This feature eliminates the need for a control cabinet situated separately from the actuator, because all switching and control components are mounted directly on the actuator. In this power class, the double controller is available for actuators in the AB series only.

## Digitization

In terms of operation, the AB series adheres to the most modern principles. The Smartcon controller developed in-house at SCHIEBEL ensures user-friendly start-up and easy, reliable operation. The Smartcon controller naturally meets all digitization and IoT requirements and, where needed, provides interfaces with all important field buses.

## Servicing

In all its development efforts, SCHIEBEL always has the customer and servicing in mind. The wear-resistant mechanical system with its economical electric actuator efficiently reduces maintenance costs for the user. Comprehensive monitoring and diagnostic functions have been integrated into the actuators. Remote control features and SCHIEBEL on-site service ensure reliable operation.

## Flexibility

The reliable control design in the AB series allows the use of mechanical or electronic reversing contactors. Moreover, the actuators can be equipped for use in a wide variety of clamping systems. That means SCHIEBEL AB actuators can also cover applications in plant networks with clamping systems or levels that are rarely used. As an option, the actuators can be fitted with a frequency converter, allowing them to be used as high-torque continual linear actuators with a high cycle number.

**SCHIEBEL**

SCHIEBEL  
Actuators GmbH  
Managing Director Klaus Schiebel  
Josef-Benc-Gasse 4, A 1230 Vienna  
UID ATU42150300  
Company Registration Number 154745  
Company Headquarter Vienna  
+43 1 66 108 0  
info@schiebel-actuators.com  
www.schiebel-actuators.com

**schiebel  
-actuators  
.com**