

Rising Ball Sight Flow Indicator



Manufacturer of Specialist Flow Instruments

The Flow-Mon rising ball was developed to provide industry a high standard in-line flow indicator to meet the requirements for a broad range of chemical, water, oil and gas applications.

When calibrated, flow indicators are not needed. The rising ball will satisfy most requirements within pipe sizes 8mm to 40mm.

With no flow in the pipe, the white PTFE ball remains seated in the body socket. As the flow rises the ball will lift out of the socket, becoming clearly visible. The ball will continue to rise and move freely in the dome as the flow rate increases. The Flow-Mon rising ball must be mounted on a horizontal plane, with the glass dome positioned upwards. When there is flow in the pipes the ball can be seen clearly, giving a positive confirmation of flow.



Product Application

- Plant protection to show lubrication or coolant flow to pumps, compressors or engines.
- Detecting changes in the colour and condition of liquids during processing.
- Pump, compressor and diesel protection.
- Ensuring that flow of cooling water is maintained to specialized welding equipment.
- Indication of air entertainment.
- Indicating chemical dosing on water treatment facilities.
- Showing the presence of condensate in steam return lines.
- Maintaining demineralised water rinsing essential to electronics components manufacture.

Features & Benefits

- 8 - 40mm connection available
- Easy to install (horizontal plane only)
- No routine maintenance required
- Unrivalled flow and pressure drop performance
- Robust with good shock and vibration resistance
- Resistant to a wide range of chemicals
- Can be used for condensate
- Bronze or stainless steel

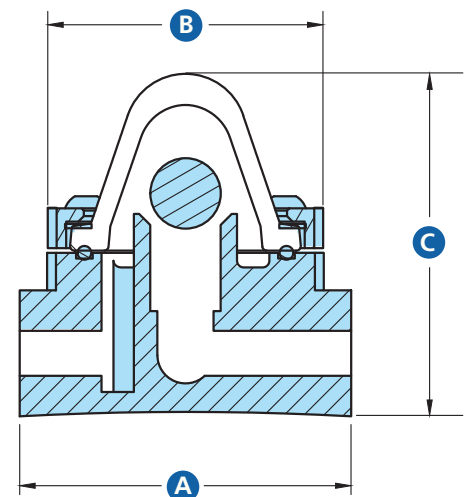

Dimensions

A	B	C
mm	mm	mm
76	63	79
76	63	79
76	63	79
89	63	95
89	63	95
117	75	125
117	75	125

Flow Rates & Weight

Size		Weight	Min Flow	Out of Socket	Max Flow	Pressure Drop - 2m/sec
mm	inch	kg	l/min	l/min	l/min	bar
8	1/4	0.72	0.1	1.0	60	0.13
10	3/8	0.69	0.1	1.0	60	0.16
15	1/2	0.65	0.1	1.0	65	0.19
20	3/4	1.30	2.4	5.2	150	0.16
25	1	1.25	2.7	5.5	165	0.40
32	1 1/4	2.50	11.0	16.0	400	0.20
40	1 1/2	2.35	16.0	21.0	450	0.23

Part Code Builder

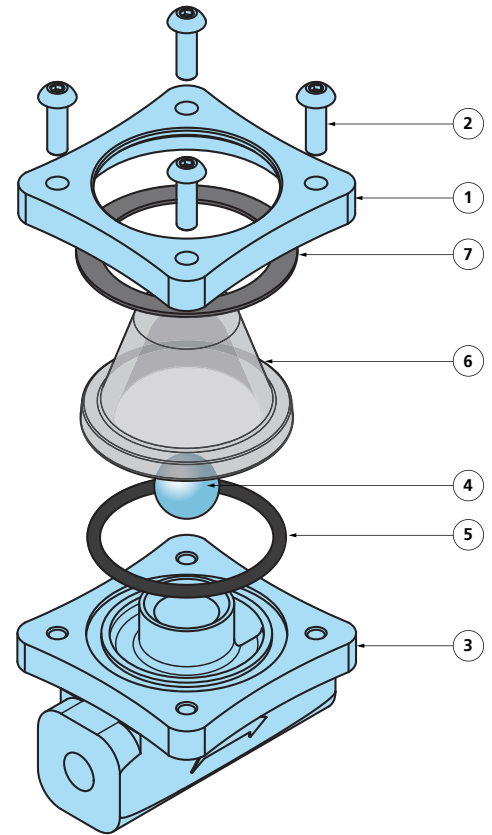
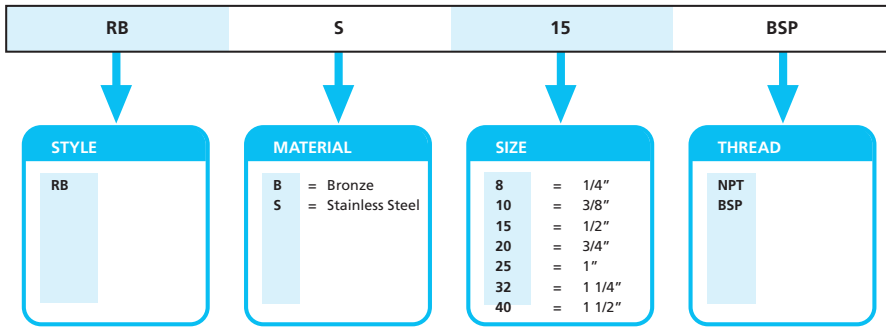

Parts List

Item	Qty	Part No.	Description	Material
1	1	7005	Lid	Stainless Steel, Bronze
2	4	7019	M5 x16 button head screw	Stainless Steel
3	1	7001	Sight indicator body	Stainless Steel, Bronze
4	1	7104	PTFE Ball (5/8")	Polytetrafluoroethylene
5	1	7105	'O' Ring	Viton
6	1	7008	Glass Dome	Annealed Borosilicate
7	1	7016	Gasket	Klingersil

Technical Instructions

The flow indicators are in-line devices. Mounting must be horizontal, and no straight length of pipe is required before or after the unit. Under the Pressure Equipment Directive (PED) these products are Pressure Accessories and are not approved for use as safety accessories, as defined by the PED. If used for safety purposes, it is the responsibility of the user/installer to assess the suitability of the product in the pressure equipment or system in which it is used.

It is the responsibility of the user/installer of this equipment to ensure:

1. The product is installed and used by suitably trained personnel in accordance with all relevant local and national regulations and codes.
2. Safe working practices for the media and processes concerned are followed during installation and maintenance.
3. The materials of construction are suitable for the application.
4. The product is protected from fire.

5. The product is protected from impact/vibration.
6. For outdoor use in exposed positions the instrument must be additionally protected/shielded from heavy rainfall.
7. Regular inspection for corrosion/erosion and wear are carried out.
8. End cap torque setting is 7nm. Over tightening the end caps will damage the sealing face of the body causing the unit to leak.

Essential Safety Requirements

1. The instrument must be installed in accordance with the instructions provided.
2. Prior to installation drain pipelines to ensure they are free from any solid particles or pressure.
3. Care must be taken to avoid introducing torsional stress on the instrument when installing into the pipeline. Tighten sufficiently to avoid leaks and check at regular intervals during maintenance.

4. Ensure pipelines are fully primed before commencing normal use.
5. Valves must be opened or closed gradually to avoid shock/vibration.
6. Do not exceed maximum working pressure as stated.
7. Only use with the fluid/gas stated on the label.
8. Do not exceed minimum/maximum working temperature as stated.

General Maintenance

1. Remove instrument from pipeline.
2. Check for and remove any swarf/foreign body. Clean if necessary.
3. The instrument is only cleaned by washing with detergent. Do not use abrasive cleaners or solvents.
4. Re-assemble instrument.

