



## TECHNICAL DATASHEET



The TRICOR PRO series offers robustness and excellent performance combined with state-of-the-art diagnostic functionality. An HMI interface provides traceable logging of all relevant device data. With the advanced DSP transmitter, powerful analysis is provided in addition to systematic menu navigation for parameter setting.

- TCD 9000 transmitter with digital signal processing and extended diagnostic functionality
- Suitable for demanding measurement applications
- Traceable logging of all setting parameters
- Output of the concentration of two-phase mixtures



*Our passion is*  
**your *Process***



# CONTENT

Description, Principle of operation .....	04
Product Overview .....	05
TCMP Sensor – Technical Data for Liquids .....	06
Accuracy for Liquids .....	07
TCMP Sensor – Technical Data for Gases .....	08
Accuracy for Gases .....	09
TCD 9100/9200 Transmitter – Technical Data .....	10
SD-Card .....	10
TCD 9010 Transmitter – Technical Data .....	11
Bus Communication .....	11
Dimensional Drawings .....	12
Ordering Code TCMP Sensor and Transmitter .....	16
Process Connections .....	18
Contact .....	24



## DESCRIPTION

The TCMP PRO product line with extended diagnostic functionalities addresses challenging measurement requirements. The transmitters of the TCD 9000 series are characterized above all by great robustness and performance. Their technology platform offers a wide range of interfaces. Thus, the TCD 9000 series is prepared for today's and future industrial standards to be seamlessly integrated into logic control and distribution control systems.

TRICOR Coriolis mass flow meters of the PRO series extend the sensors already known from the CLASSIC series with the latest digital signal processing. With our well-known sensors, which are characterised by a high variance of process connections and pressure levels, we combine flexible sensor technology with the latest processor technology. An improved signal-to-noise ratio is particularly evident in the application's limit ranges. Reliable, high measuring accuracy and increased reproducibility with extended flow dynamics are the result.

## FEATURES

- Digital Signal Processing:
  - Short response time to rapid flow changes, 100 Hz update rate, response time  $\leq 10$  ms
  - Improved signal to noise ratio
  - Extended diagnostic functionality
- Ease of Use:
  - Integrated SD card with memory function<sup>1)</sup>, guarantee of traceability
  - Modular universal I/O configuration
  - Modern, adaptable displays, 6 views and Trend curves
  - Damping functionality for pumps
  - Error monitoring
- Integrated fractionation tables (expandable to customer-specific liquids)
- Password protection (multi-level)
- Multi-voltage power supply unit for AC and DC
- DAkkS accreditation as per DIN EN ISO/IEC 17025:2018
- Customer-specific process connections available

## ADDITIONAL OPTIONS

- Multiple protocols supported : Modbus, HART®, Profibus DP, Profibus PA
- Available as meter mount and remote versions
- Calibration maintenance services
- Tailored customer solutions
- DAkkS accreditation as per DIN EN ISO/IEC 17025:2018

## PRINCIPLE OF OPERATION

Coriolis Mass Flow Meters (TCMP) operate with two parallel tubes with coils that cause them to oscillate at their resonance frequency. Should a measurement flow enter the measuring tube, Coriolis forces are the result. Coriolis forces appear in oscillating systems when a mass moves towards or away from a rotational axis. These forces act on the inlet and outlet side in the opposite direction and minimally deform the measuring tubes. The deflection of the measurement tubes is captured by sensors on the inflow and outflow side. These two sensors measure a phase shift that is proportional to the mass flow. The resonance frequency of the tubes varies depending on the density of the medium to be measured. This effect is used to measure the density of the medium. Since the elastic properties of the flow tubes depend on the temperature, a temperature measurement is carried out for compensation. The primary characteristics such as mass flow rate, density and temperature are measured with a single flow meter. The volume flow can be determined based on the mass flow rate and density.

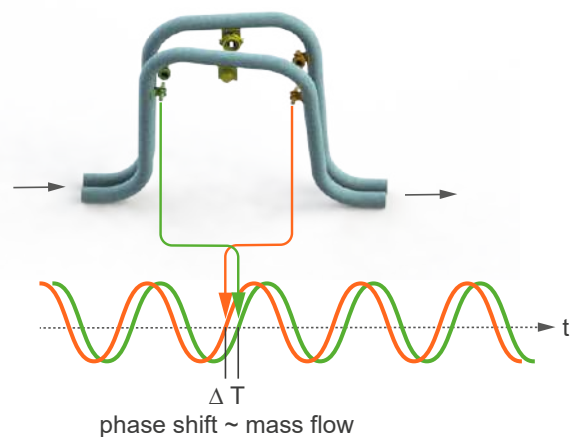



## PRODUCT OVERVIEW

### Basic version



### Compact version



### Wall mounted (remote version)





## TCMP SENSOR – TECHNICAL DATA FOR LIQUIDS

	TCMP 0325	TCMP 0650	TCMP 1550	TCMP 3100	TCMP 5500	TCMP 7900	TCMP 028K	TCMP 065K	TCMP 230K
Max. Flow Rate (kg/h)	325	650	1,550	3,100	5,500	7,900	28,000	65,000	230,000
Max. Flow Rate (lb/min)	12	24	57	114	202	290	1,029	2,388	8,450
Basic Accuracy (Mass Flow)	±0.1 % of flow rate								
Basic Accuracy (Volume Flow)	0.15 % of flow rate								
Repeatability	better than ±0.05 % of flow rate								
Zero Stability	±0.01 % of full scale								
Density Range	up to 2,500 kg/m <sup>3</sup> [2.5 g/cm <sup>3</sup> ] (higher ranges on request)								
Density Accuracy	±1.0 kg/m <sup>3</sup> [±0.001 g/cm <sup>3</sup> ]								
Density Repeatability	±0.5 kg/m <sup>3</sup> [±0.0005 g/cm <sup>3</sup> ]								
Process Temperature Range	±1 °C ±0.5 % of reading [±1.8 °F ±0.5 % of reading]								
Temperature Repeatability	±0.2 °C [±0.36 °F]								

Process and Ambient		
Process Connections	female thread ½" adaptors for flanges, dairy and tri-clamp	flanges EN1092, ANSI B16.5, DIN2512, threaded tri-clamp
Max. Pressure Standard	200 bar [2,900 psi] option: up to 345 bar [5,000 psi] (not for ASME)	100 bar [1,450 psi]
Pressure Drop at max. Flow	for detail information please contact us	
Process Temperature	-60 °C ... +200 °C [-76 °F ... +392 °F]	
Ambient Temperature (Humidity max. 90 %)	-40 °C ... +60 °C [-40 °F ... +140 °F] (depending on transmitter and installation environment; for details refer to instruction manual)	
Storage Temperature	-40 °C ... +70 °C [-40 °F ... +158 °F]	

Ingress Protection	IP65 (IP67/NEMA 4X to EN/IEC 60529 (1 mH <sub>2</sub> O for 30 min.) on request)
--------------------	--

General									
Tube Arrangement	2 serial	2 parallel	2 serial	2 parallel	2 parallel	2 parallel	2 parallel	2 parallel	2 parallel
Tube Inner Diameter	4 mm	4 mm	8 mm	8 mm	7 mm	9 mm	16 mm	28 mm	43 mm
Tube Material	1.4404 [AISI 316L]								
Housing Material	1.4404 [AISI 316L]								
Dimensions	see dimensional drawings (page 12 - 13)								

*Calibration for Liquids and Gases: The TRICOR flowmeters are always factory calibrated with water.  
 Calibration Conditions: Water: 20 °C ... 25 °C [68 °F ... 77 °F], ambient temperature: 20 °C ... 25 °C [68 °F ... 77 °F].  
 All specifications are based on above mentioned calibration reference conditions, a flow calibration protocol is attached to each instrument.  
 Stated accuracy combines the effects of repeatability, linearity and hysteresis.  
 Typical flow dynamics based on max. flow rate is 100:1.*



## ACCURACY FOR LIQUIDS

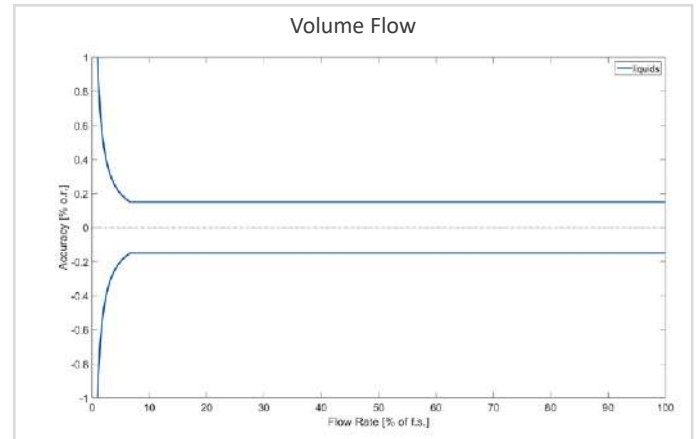
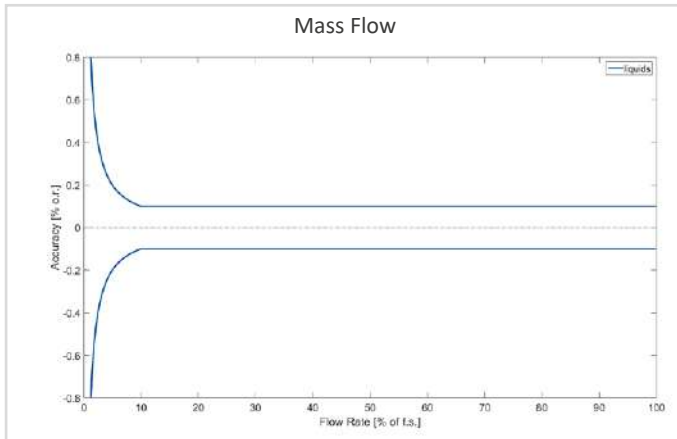

Flow Rate of Full Scale	Accuracy
$\geq \frac{\text{Zero Point}}{\text{Basic Accuracy}} * 100$	$\pm \text{Basic Accuracy}$
$< \frac{\text{Zero Point}}{\text{Basic Accuracy}} * 100$	$\pm \frac{\text{Zero Point}}{\text{Measured Value}} * 100$



## TCMP SENSOR – TECHNICAL DATA FOR GASES

	TCMP 0325	TCMP 0650	TCMP 1550	TCMP 3100	TCMP 5500	TCMP 7900	TCMP 028K	TCMP 065K	TCMP 230K
Nom. Flow Rate (kg/h) <sup>2) 4)</sup>	78	177	333	740	910	1,430	5,100	15,650	48,900
Nom. Flow Rate (lb/min) <sup>2) 4)</sup>	3	7	12	27	34	53	188	575	1,797
Nom. Flow Rate (Nm <sup>3</sup> /h) <sup>2) 3)</sup>	109	247	464	1,031	1,268	1,993	7,109	21,813	68,157
Nom. Flow Rate (SCFM) <sup>2) 3)</sup>	64	146	273	607	747	1,173	4,184	12,838	40,115
Basic Accuracy	±0.5 % of flow rate								
Repeatability	±0,25 % of flow rate								
Zero Stability (kg/h)	0.0325	0.065	0.155	0.31	0.55	0.79	2.8	6.5	23
Zero Stability (lb/min)	0.0012	0.0024	0.0057	0.0114	0.020	0.029	0.103	0.239	0.845
Density Range	see comment <sup>3)</sup>								
Density Accuracy	±1.0 kg/m <sup>3</sup> [±0.001 g/cm <sup>3</sup> ]								
Density Repeatability	±0.5 kg/m <sup>3</sup> [±0.0005 g/cm <sup>3</sup> ]								
Process Temperature Range	±1 °C ±0.5 % of reading [±1.8 °F ±0.5 % of reading]								
Temperature Repeatability	±0.2 °C [±0.36 °F]								
<b>Prozess-/Umgebungsbedingungen</b>									
Process Connections	female thread ½“ adaptors for flanges, dairy and tri-clamp				flanges EN1092, ANSI B16.5, DIN2512, threaded tri-clamp				
Max. Pressure Standard	200 bar [2,900 psi] option: up to 345 bar [5,000 psi] (not for ASME)					100 bar [1,450 psi]			
Pressure Drop at max. Flow	for detail information please contact us								
Process Temperature	-60 °C ... +200 °C [-76 °F ... +392 °F]								
Ambient Temperature (Humidity max. 90 %)	-40 °C ... +60 °C [-40 °F ... +140 °F] (depending on transmitter and installation environment; for details refer to instruction manual)								
Storage Temperature	-40 °C ... +70 °C [-40 °F ... +158 °F]								
Ingress Protection	IP65 (IP67/NEMA 4X to EN/IEC 60529 (1 mH <sub>2</sub> O for 30 min.) on request)								
<b>General</b>									
Tube Arrangement	2 serial	2 parallel	2 serial	2 parallel	2 parallel	2 parallel	2 parallel	2 parallel	2 parallel
Tube Inner Diameter	4 mm	4 mm	8 mm	8 mm	7 mm	9 mm	16 mm	28 mm	43 mm
Tube Material	1.4404 [AISI 316L]								
Housing Material	1.4404 [AISI 316L]								
Dimensions	see dimensional drawings (page 12 - 13)								

Max. allowed flow velocity (Ma 0.5).

For gas applications, flow rate and pressure drop for individual sensor sizes are dependent on operating temperature, pressure and fluid composition. Therefore, when selecting a sensor for any particular gas application, please use the the TSP (TRICOR Sizing Program) or contact us.

<sup>2)</sup> Nominal flow rates that produce approximately 3 bar [43 psi] pressure drop for natural gas at 50 bar [725 psi] operational pressure.

<sup>3)</sup> Normal reference conditions (Nm<sup>3</sup>/h) are 1,013 bar und 0 °C. Standard (SCFM) reference conditions are 14.7 psi und 60 °F.

<sup>4)</sup> Flow rate and density range depend on the gas density and the pressure range.





ACCURACY FOR GASES

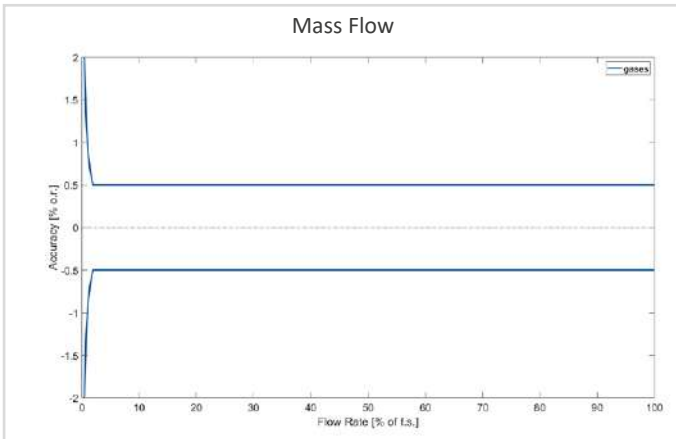

Flow Rate of Full Scale	Accuracy
$\geq \frac{\text{Zero Point}}{\text{Basic Accuracy}} * 100$	$\pm$ Basic Accuracy
$< \frac{\text{Zero Point}}{\text{Basic Accuracy}} * 100$	$\pm \frac{\text{Zero Point}}{\text{Measured Value}} * 100$

APPROVALS & CERTIFICATIONS<sup>5)</sup>

	TCM 0325, 0650, 1550, 3100, 5500 und 7900	TCM 028K, 065K und 230K
<b>ATEX Zone 1</b>	Ex db ia [ia Ga] IIC T* Gb	Ex db ia [ia Ga] IIB T* Gb
<b>ATEX Zone 2</b>	II 3G nR nA IIC T4	II 3G nR nA IIC T4
<b>IECEX</b>	Ex db ia [ia Ga] IIC T* Gb	Ex db ia [ia Ga] IIB T* Gb
<b>cCSAus</b>	Canadian Marking: Ex db ia [ia Ga] IIC T* Gb	Canadian Marking: Ex db ia [ia Ga] IIB T* Gb
	US Zones Marking: Cl. 1, Zone 1 AEx db ia [ia Ga] IIC T4-T3 Gb	US Zones Marking: Cl. 1, Zone 1 AEx db ia [ia Ga] IIB T4-T3 Gb
	US Divisions Marking: Cl. 1, Div. 1 Groups A, B, C and D, T*	US Divisions Marking: Cl. 1, Div. 1 Groups C and D, T*

<sup>5)</sup> T\* refer to Ex-certificate.



## TCD 9100/9200 TRANSMITTER – TECHNICAL DATA

General	
Display	240 x 160 pixels
Supply Voltage	24 V DC 100 ... 240 V AC
Power Consumption	7.5 W/15 VA
Interfaces	Channel 1: HART 7.5 or Profibus PA/DP or Modbus RTU Channel 2/3/4: Plug-In I/O Card
Housing Material	Aluminum
Ingress Protection	IP65, option: IP67 NEMA 4X to IEC 529 and DIN 40050 (1 mH <sub>2</sub> O for 30 min.)
EMC	EN 55011/CISPR-11 (Class A), EN/IEC 61236-1 (Industry)
Dimensions	See dimensional drawings (pages 14 - 15)
Weight	Meter-mount electronics: 4.5 kg [9.9 lb] Wall-mount electronics: 5.6 kg [12.3 lb]
Temperature	
Ambient Temperature <sup>6)</sup> (Humidity max. 90 %)	-40 °C ... +60 °C [-40 °F ... +140 °F]
Storage and Transport	-40 °C ... +70 °C [-40 °F ... +158 °F]
Connectivity	
Cable (TCD 9200)	Standard industrial signal cable up to 200 m long, 2x screened pairs or 4-wire overall
Cable Gland	½" NPT M20x1.5
Plugin I/O-card	
Available Cards	Option 1: Signal I/O, Signal I/O, Signal I/O Option 2: Signal I/O, Signal I/O, Relay
Signal I/O <sup>7)</sup>	Configurable universal I/O channels: current output, digital output or digital input  Current Output: 0 ... 20 mA or 4 ... 20 mA (CH1 only 4 ... 20 mA) Digital Output: Pulse: 41.6 µs ... 5 s pulse duration Frequency: 0 ... 10 kHz Active: 0 ... 24 V DC, 110 mA Passiv: 3 ... 30 V DC, 100 mA Digital Input: 15 ... 30 V DC, 2 ... 15 mA
Relay	Voltage-free contact, 30 V DC, 100 mA
Output Value (programmable)	Mass flow, volume flow, total mass, total volume, corrected volume, density, temperature, fraction (flow/mass/%), alarms

## SD-CARD

Description	Specification SD-Card (for transmitters with display)
Capacity	4 GB
File System Support	FAT32 / 8.3

<sup>6)</sup> Depending on transmitter and installation environment (for details refer to instruction manual).

<sup>7)</sup> Version-dependent.



## TCD 9010 TRANSMITTER – TECHNICAL DATA

General	
Supply Voltage	24 V DC
Interfaces	Modbus RTU
Housing Material	Aluminum
Protection Class	IP67 NEMA 4X nach IEC 529 und DIN 40050 (1 mH <sub>2</sub> O für 30 min.)
EMC	EN 55011/CISPR-11 (Class A), EN/IEC 61236-1 (Industry)
Dimensions	See dimensional drawing (page 14)
Weight	1.4 kg [3.1 lb]
Temperature	
Ambient Temperature <sup>8)</sup> (Humidity max. 90 %)	-40 °C ... +60 °C [-40 °F ... +140 °F]
Storage and Transport	-40 °C ... +70 °C [-40 °F ... +158 °F]
Connectivity	
Cable	Standard industrial signal cable up to 200 m long, 2x screened pairs or 4-wire overall
Cable Gland	½" NPT M20 (on request)

## BUS COMMUNICATION

Description	Specification	More information
Manufacturer ID	24816 (60F0 Hex)	Manufacturer ID parameter
Device ID	34 (22 Hex)	Device type parameter
HART Protocol Revision	7.5	HART protocol revision parameter
Profibus Profile	4.0	Profibus protocol revision parameter
Modbus RS485 RTU	—	—
Number of Device Variables	11	Number of process values, both measured and derived
Physical Layers Supported	FSK	Frequency Shift Keying
Loop-Powered	No	4-wire device

<sup>8)</sup> Depending on transmitter and installation environment (for details refer to instruction manual).



## TCM 0325 TO TCM 0650

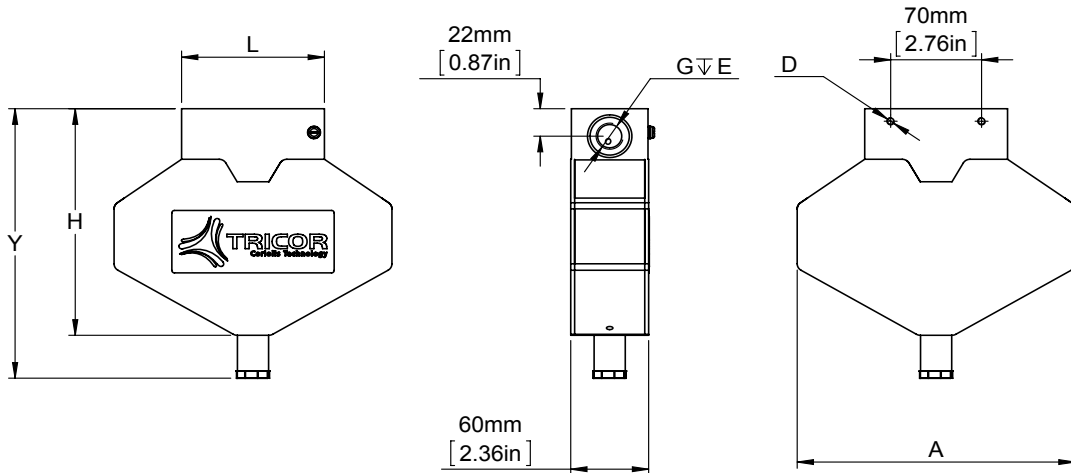

Sensor Type	A	D	E	G <sup>9)</sup>	H	L <sup>10)</sup>	Y
TCMP 0325	214 mm [8.43 in]	M6 ∇ 10	21 mm [0.83 in]	G ½"	182 mm [7.17 in]	110 mm [4.33 in]	216 mm [8.50 in]
TCMP 0650	214 mm [8.43 in]	M6 ∇ 10	21 mm [0.83 in]	G ½"	182 mm [7.17 in]	110 mm [4.33 in]	216 mm [8.50 in]

## TCM 1550 TO TCM 3100

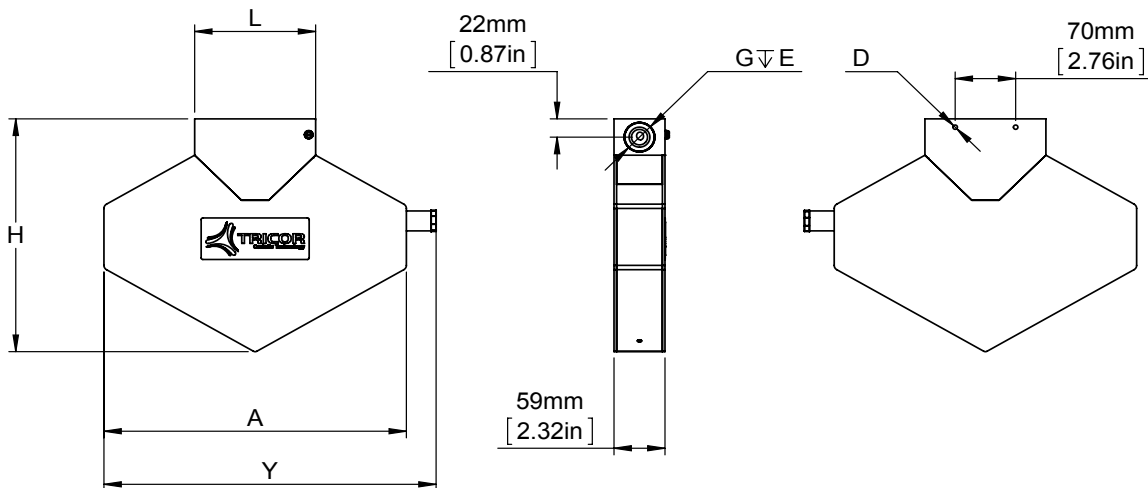

Sensor Type	A	D	E	G <sup>9)</sup>	H	L <sup>10)</sup>	Y
TCMP 1550	350 mm [13.78 in]	M6 ∇ 10	18 mm [0.71 in]	G ½"	280 mm [11.02 in]	140 mm [5.51 in]	384 mm [15.12 in]
TCMP 3100	350 mm [13.78 in]	M6 ∇ 10	18 mm [0.71 in]	G ½"	280 mm [11.02 in]	140 mm [5.51 in]	384 mm [15.12 in]

<sup>9)</sup> Other connections on request.

<sup>10)</sup> Further lengths on request.



## TCM 5500 TO TCM 065K

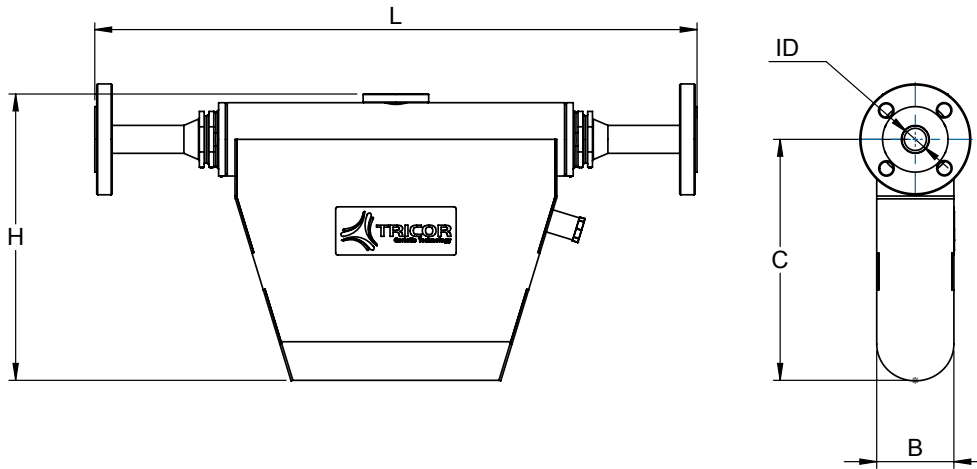

Sensor Type	B	C	H	L <sup>1)</sup>	I.D.	Connection
TCMP 5500, 7900	61 mm [2.40 in]	204 mm [8.03 in]	260 mm [10.24 in]	460 mm [18.11 in]	∅ 13 mm [∅ 0.51 in]	on request
TCMP 028K	80 mm [3.15 in]	253 mm [9.96 in]	315 mm [12.40 in]	625 mm [24.61 in]	∅ 23 mm [∅ 0.91 in]	on request
TCMP 065K	151 mm [5.94 in]	387 mm [15.24 in]	480 mm [18.90 in]	830 mm [32.68 in]	∅ 40 mm [∅ 1.57 in]	on request

## TCM 230K (basic and remote versions only)

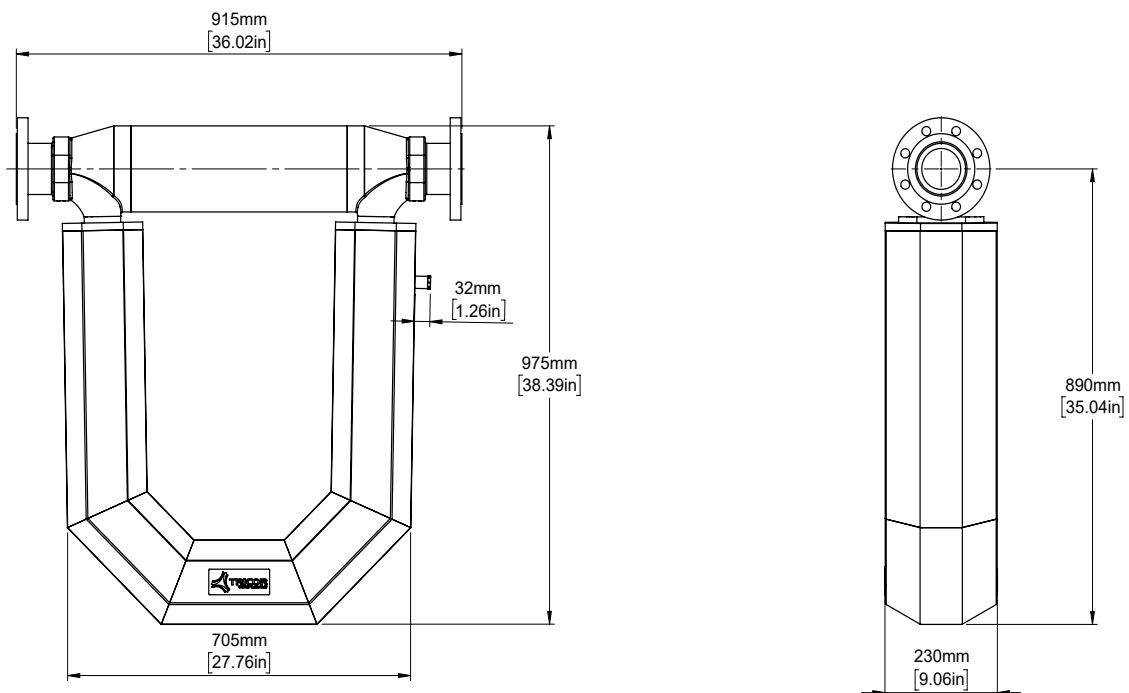

<sup>1)</sup>Further lengths on request.



## COMPACT TRANSMITTER TCD 9010

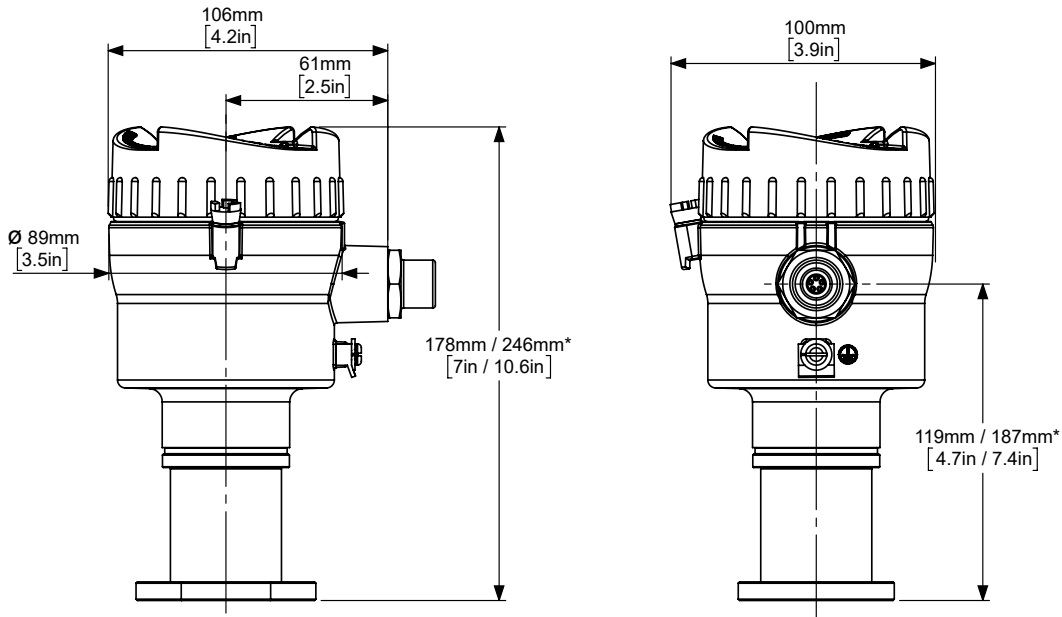

\* Dimension depending on meter configuration / temperature option.

Sensor Typ	Process temperature up to +135 °C [+275 °F]	Process temperature up to +200 °C [+392 °F]
TCMP 0325, 0650, 1550, 3100	178 mm [7 in]	246 mm [10,6 in]
TCMP 5500, 7900, 028K, 065K, 230K	178 mm [7 in]	

## METER-MOUNT TRANSMITTER TCD 9100

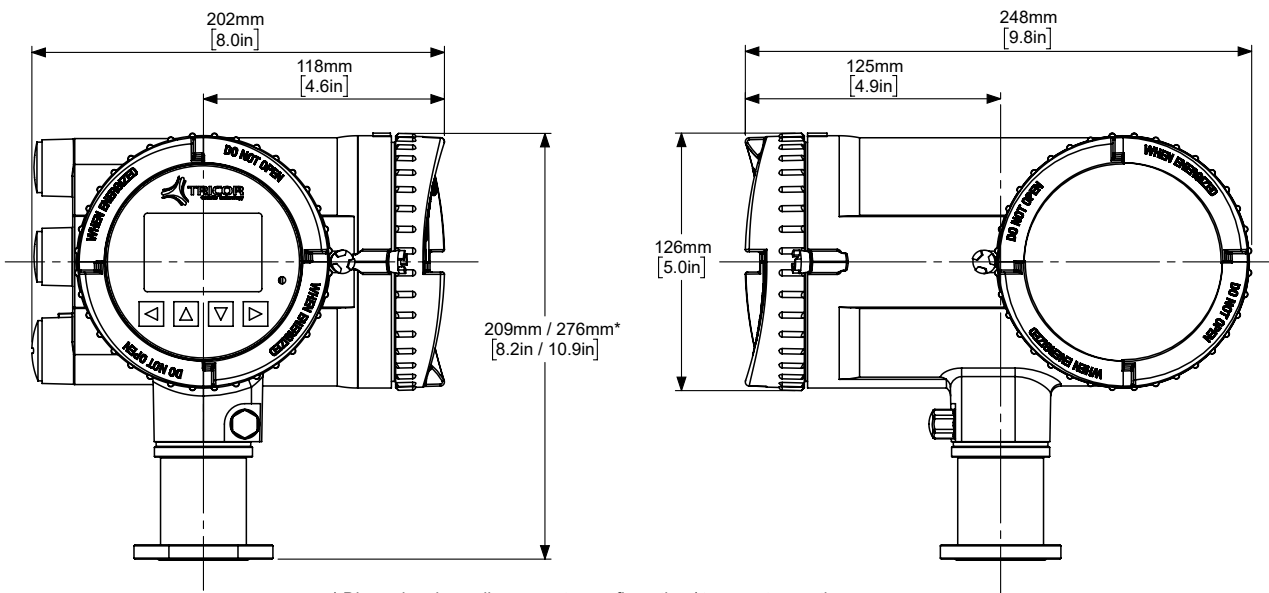

\* Dimension depending on meter configuration / temperature option.

Sensor Typ	Process temperature up to +135 °C [+275 °F]	Process temperature up to +200 °C [+392 °F]
TCMP 0325, 0650, 1550, 3100	209 mm [8,2 in]	276 mm [10,9 in]
TCMP 5500, 7900, 028K, 065K, 230K	209 mm [8,2 in]	



METER-MOUNT TRANSMITTER TCD 9200

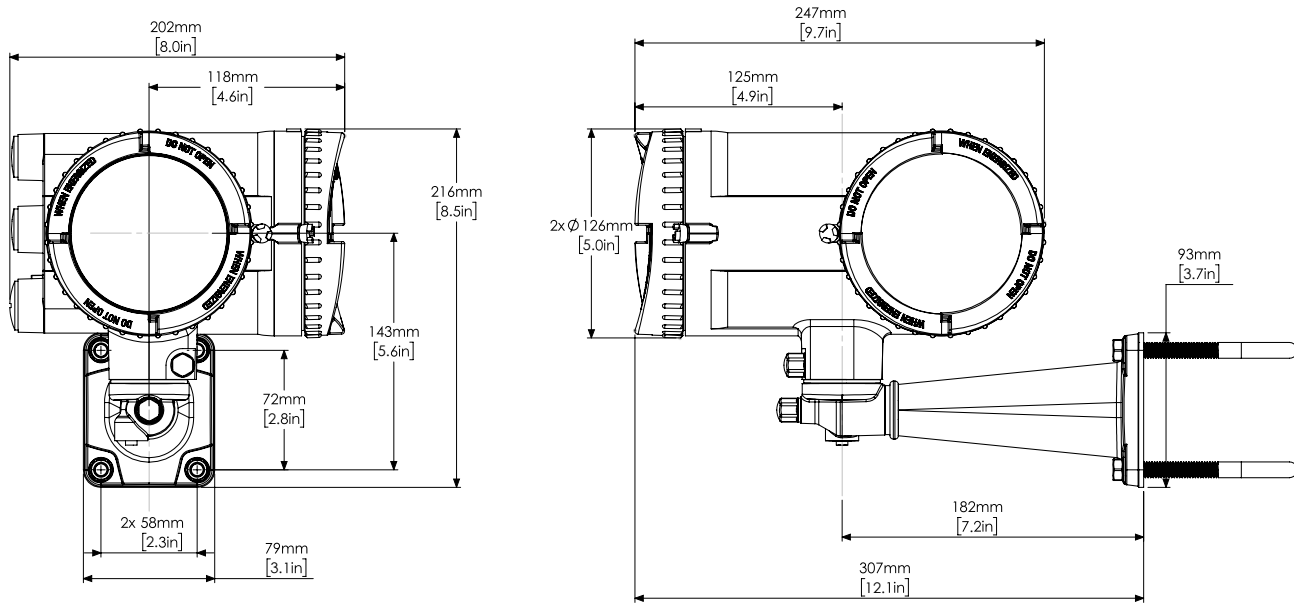



## ORDERING CODE TCMP SENSOR AND TRANSMITTER (TRICOR PRO SERIES)

TCMP	XXXX	-	XX	-	X	X	X	X	-	X	X	X	-	Ex	-	XXX
<b>Process Connections</b>																
see page 20 ff			XX													
<b>Mechanical Options</b>																
<b>Medium Temperature Range</b>																
-60 °C ... +200 °C [-76 °F ... +392 °F]							T									
-40 °C ... +200 °C [-40 °F ... +392 °F]							U									
-40 °C ... +135 °C [-40 °F ... +275 °F]							V									
<b>Rupture Disc/Pressure Range</b>																
With rupture disc max. 4 bar [58 psi] + max. operating pressure: 345 bar [5,000 psi]												B				
With rupture disc max. 4 bar [58 psi] + standard pressure												G				
<b>Mechanical Design / Measuring Accuracy</b>																
Standard, ±0.1 % o.r. + zero point stability, with water at 20 °C [68 °F] (Gas ±0.5 %)												S				
<b>Face to Face Length</b>																
Standard (other length on request)													S			
<b>Electronics Options</b>																
<b>Electronics Type</b>																
TCD 9010 - direct meter mount electronics without display, ½" NPT, 24 V DC																W
TCD 9010 - direct meter mount electronics without display, M20x1.5, 24 V DC																V
TCD 9100 - direct meter mount electronics with display, ½" NPT, 24 V DC / 100 ... 240 V AC																T
TCD 9100 - direct meter mount electronics with display, M20x1.5, 24 V DC / 100 ... 240 V AC																K
TCD 9200 - remote display + link modul, ALU, ½" NPT, 24 V DC / 100 ... 240 V AC																R
TCD 9200 - remote display + link modul, ALU, M20x1.5, 24 V DC / 100 ... 240 V AC																I
<b>Interface</b>																
Current output 4 ... 20 mA HART active/passive (factory setting= active) (non Ex)																G
Current output 4 ... 20 mA HART active (Ex)																H
Current output 4 ... 20 mA HART passive (Ex)																I
Profibus PA (non Ex)																N
Profibus PA (Ex)																J
Profibus DP (non Ex)																K
Modbus RTU (non Ex)																L
Modbus RTU (Ex)																M
<b>Plug-In I/O-Card</b>																
None																A
Signal I/O, Signal I/O, Signal I/O (Non-Ex)																D
Signal I/O, Signal I/O, Relay (Non-Ex)																E
Signal I/O, Signal I/O, Signal I/O (Ex active)																F
Signal I/O, Signal I/O, Relay (Ex active)																G
Signal I/O, Signal I/O, Signal I/O (Ex passive)																J
Signal I/O, Signal I/O, Relay (Ex passive)																K
<b>EX-Protection<sup>12)</sup></b>																
ATEX+IECEX, Zone 1: Group IIC, T* (T* refer to Ex-certificate)																Ex
cCSAus: Class 1, Div. 1: Group A - D, T* (T* refer to Ex-certificate)																Ex1
ATEX+IECEX+cCSAus, Zone 1: Group IIC, (T* refer to Ex-certificate)																Ex3
ATEX Zone 2: 3G Ex nR nA IIC T4																Exn
<b>Cable Length</b>																
TCD 9200 Remote M12 Cable, 3 m [10 ft], Standard																L03
TCD 9200 Remote M12 Cable, 6 m [20 ft]																L06
TCD 9200 Remote M12 Cable, 10 m [33 ft]																L10
TCD 9200 Remote M12 Cable, 15 m [49 ft]																L15
TCD 9200 Remote M12 Cable, 20 m [66 ft]																L20

<sup>12)</sup> T\* refer to Ex-certificate.





## ACCESSORIES

Service and calibration	Model Code
DAkkS-Calibration (ILAC) according to DIN EN ISO/IEC 17025:2005	3.KAL-0100
Inspection certificate 3.1 according to DIN 50 049 / EN 10204	3.WKZ-0100
Oxygen cleaning TCM	219269
TAG Plate 1.4404 [AISI 316L]	219705
Silicone free	224037





## SLIP ON, PROCESS CONNECTION DIM. + FACING ACC. ANSI B16.5 INSTALLATION LENGTH IN MM [INCH]

Process connection <sup>13)</sup>	Code	TCM 0325	TCM 0650	TCM 1550	TCM 3100	TCM 5500	TCM 7900	TCM 028K	TCM 065K	TCM 230K
½" ANSI flange class 150	AA	390 [15.35]	390 [15.35]	420 [16.54]	420 [16.54]	460 [18.11]	460 [18.11]			
½" ANSI flange class 300	AB	390 [15.35]	390 [15.35]	420 [16.54]	420 [16.54]	460 [18.11]	460 [18.11]			
½" ANSI flange class 600	AC	390 [15.35]	390 [15.35]	420 [16.54]	420 [16.54]	460 [18.11]	460 [18.11]			
½" ANSI flange class 900	AD	390 [15.35]	390 [15.35]	420 [16.54]	420 [16.54]	460 [18.11]	460 [18.11]			
½" ANSI flange class 1500	BV	390 [15.35]	390 [15.35]	420 [16.54]	420 [16.54]	460 [18.11]				
½" ANSI flange class 2500	BE	390 [15.35]	390 [15.35]	420 [16.54]	420 [16.54]					
¾" ANSI flange class 150	BA	390 [15.35]	390 [15.35]	420 [16.54]	420 [16.54]	460 [18.11]	460 [18.11]			
¾" ANSI flange class 300	BB	390 [15.35]	390 [15.35]	420 [16.54]	420 [16.54]	460 [18.11]	460 [18.11]			
¾" ANSI flange class 600	BC	390 [15.35]	390 [15.35]	420 [16.54]	420 [16.54]	460 [18.11]	460 [18.11]			
¾" ANSI flange class 900	BD	390 [15.35]	390 [15.35]	420 [16.54]	420 [16.54]	460 [18.11]	460 [18.11]			
¾" ANSI flange class 1500	AI	390 [15.35]	390 [15.35]	420 [16.54]	420 [16.54]					
1" ANSI flange class 150	AE	390 [15.35]	390 [15.35]	420 [16.54]	420 [16.54]	460 [18.11]	460 [18.11]	625 [24.61]		
1" ANSI flange class 300	AF	390 [15.35]	390 [15.35]	420 [16.54]	420 [16.54]	460 [18.11]	460 [18.11]	625 [24.61]		
1" ANSI flange class 600	AG	390 [15.35]	390 [15.35]	420 [16.54]	420 [16.54]	460 [18.11]	460 [18.11]	625 [24.61]		
1" ANSI flange class 900	AH	390 [15.35]	390 [15.35]			460 [18.11]	460 [18.11]	625 [24.61]		
1" ANSI flange class 1500	AQ	390 [15.35]	390 [15.35]			460 [18.11]				
1" ANSI flange class 2500	BN	390 [15.35]	390 [15.35]							
1½" ANSI flange class 150	AJ					460 [18.11]	460 [18.11]	625 [24.61]		
1½" ANSI flange class 300	AK					460 [18.11]	460 [18.11]	625 [24.61]		
1½" ANSI flange class 600	AL					460 [18.11]	460 [18.11]	625 [24.61]		
1½" ANSI flange class 900	AM					460 [18.11]	460 [18.11]	625 [24.61]		
1½" ANSI flange class 1500	BI					460 [18.11]				

<sup>13)</sup>Connections without installation length are not possible or need manufacturer release. Please contact the manufacturer.



SLIP ON, PROCESS CONNECTION DIM. + FACING ACC. ANSI B16.5  
INSTALLATION LENGTH IN MM [INCH]

Process connection <sup>14)</sup>	Code	TCM 0325	TCM 0650	TCM 1550	TCM 3100	TCM 5500	TCM 7900	TCM 028K	TCM 065K	TCM 230K
2" ANSI flange class 150	AN							625 [24.61]	830 [32.68]	
2" ANSI flange class 300	AO							625 [24.61]	830 [32.68]	
2" ANSI flange class 600	AP							625 [24.61]	830 [32.68]	
2" ANSI flange class 900	AR							625 [24.61]	830 [32.68]	
2" ANSI flange class 1500	BU								830 [32.68]	
2½" ANSI flange class 150	BT								830 [32.68]	
2½" ANSI flange class 300	BY								830 [32.68]	
2½" ANSI flange class 600	BQ								830 [32.68]	
2½" ANSI flange class 900	BW								830 [32.68]	
3" ANSI flange class 150	AS							625 [24.61]	830 [32.68]	915 [36.02]
3" ANSI flange class 300	AT								830 [32.68]	915 [36.02]
3" ANSI flange class 600	AU								830 [32.68]	915 [36.02]
3" ANSI flange class 900	AV								830 [32.68]	915 [36.02]
4" ANSI Flange class 150	AW								830 [32.68]	915 [36.02]
4" ANSI flange class 300	AX								830 [32.68]	915 [36.02]
4" ANSI flange class 600	AY								830 [32.68]	915 [36.02]
4" ANSI flange class 900	AZ								830 [32.68]	915 [36.02]
5" ANSI flange class 150	BF									915 [36.02]
5" ANSI flange class 300	BG									915 [36.02]
5" ANSI flange class 600	BH									915 [36.02]
5" ANSI flange class 900	BJ									915 [36.02]
6" ANSI flange class 150	BM									915 [36.02]
6" ANSI flange class 600	BX									915 [36.02]

<sup>14)</sup>Connections without installation length are not possible or need manufacturer release. Please contact the manufacturer.



## SLIP ON, PROCESS CONNECTION DIM. + FACING ACC. EN 1092-1 FORM B INSTALLATION LENGTH IN MM [INCH]

Process connection <sup>15)</sup>	Code	TCM 0325	TCM 0650	TCM 1550	TCM 3100	TCM 5500	TCM 7900	TCM 028K	TCM 065K	TCM 230K
DN 10, EN flange PN 40	DS	390 [15.35]	390 [15.35]	420 [16.54]	420 [16.54]					
DN 10, EN flange PN 63	DZ	390 [15.35]	390 [15.35]	420 [16.54]	420 [16.54]					
DN 10, EN flange PN 100	EA	390 [15.35]	390 [15.35]	420 [16.54]	420 [16.54]					
DN 10, EN flange PN 160	EB	390 [15.35]	390 [15.35]	420 [16.54]	420 [16.54]					
DN 10, EN flange PN 250	EC	390 [15.35]	390 [15.35]	420 [16.54]	420 [16.54]					
DN 10, EN flange PN 400	ED	390 [15.35]	390 [15.35]	420 [16.54]	420 [16.54]					
DN 15, EN flange PN 40	DA	390 [15.35]	390 [15.35]	420 [16.54]	420 [16.54]	460 [18.11]	460 [18.11]			
DN 15, EN flange PN 63	EF	390 [15.35]	390 [15.35]	420 [16.54]	420 [16.54]	460 [18.11]	460 [18.11]			
DN 15, EN flange PN 100	DB	390 [15.35]	390 [15.35]	420 [16.54]	420 [16.54]	460 [18.11]	460 [18.11]			
DN 15, EN flange PN 160	EG	390 [15.35]	390 [15.35]	420 [16.54]	420 [16.54]	460 [18.11]				
DN 15, EN flange PN 250	EH	390 [15.35]	390 [15.35]	420 [16.54]	420 [16.54]	460 [18.11]				
DN 15, EN flange PN 400	EI	390 [15.35]	390 [15.35]	420 [16.54]	420 [16.54]	460 [18.11]				
DN 20, EN flange PN 40	DT					460 [18.11]	460 [18.11]			
DN 25, EN flange PN 40	DC	390 [15.35]	390 [15.35]	420 [16.54]	420 [16.54]	460 [18.11]	460 [18.11]	625 [24.61]		
DN 25, EN flange PN 63	EJ	390 [15.35]	390 [15.35]	420 [16.54]	420 [16.54]	460 [18.11]	460 [18.11]	625 [24.61]		
DN 25, EN flange PN 100	DD	390 [15.35]	390 [15.35]	420 [16.54]	420 [16.54]	460 [18.11]	460 [18.11]	625 [24.61]		
DN 25, EN flange PN 160	DW	390 [15.35]	390 [15.35]	420 [16.54]	420 [16.54]	460 [18.11]				
DN 25, EN flange PN 160 Mat.: 2.4602	DW							625 [24.61]		
DN 25, EN flange PN 250	DP	390 [15.35]	390 [15.35]	420 [16.54]	420 [16.54]	460 [18.11]				
DN 25, EN flange PN 400	DV	390 [15.35]	390 [15.35]			460 [18.11]				
DN 32, EN flange PN 40	DR					460 [18.11]	460 [18.11]	625 [24.61]		

<sup>15)</sup>Connections without installation length are not possible or need manufacturer release. Please contact the manufacturer.



## SLIP ON, PROCESS CONNECTION DIM. + FACING ACC. EN 1092-1 FORM B INSTALLATION LENGTH IN MM [INCH]

Process connection <sup>16)</sup>	Code	TCM 0325	TCM 0650	TCM 1550	TCM 3100	TCM 5500	TCM 7900	TCM 028K	TCM 065K	TCM 230K
DN 40, EN flange PN 40	DE					460 [18.11]	460 [18.11]	625 [24.61]		
DN 40, EN flange PN 63	EK					460 [18.11]	460 [18.11]	625 [24.61]		
DN 40, EN flange PN 100	DF					460 [18.11]	460 [18.11]	625 [24.61]		
DN 40, EN flange PN 160	EL					460 [18.11]				
DN 40, EN flange PN 250	EM					460 [18.11]				
DN 40, EN flange PN 400	EN					460 [18.11]				
DN 50, EN flange PN 16	EO							625 [24.61]	830 [32.68]	
DN 50, EN flange PN 40	DG							625 [24.61]	830 [32.68]	
DN 50, EN flange PN 63	EP							625 [24.61]	830 [32.68]	
DN 50, EN flange PN 100	DH							625 [24.61]	830 [32.68]	
DN 65, EN flange PN 16	EQ								830 [32.68]	
DN 65, EN flange PN 40	DQ								830 [32.68]	
DN 65, EN flange PN 63	ER								830 [32.68]	
DN 65, EN flange PN 100	ES								830 [32.68]	
DN 80, EN flange PN 16	ET								830 [32.68]	915 [36.02]
DN 80, EN flange PN 40	DJ								830 [32.68]	915 [36.02]
DN 80, EN flange PN 63	EU								830 [32.68]	915 [36.02]
DN 80, EN flange PN 100	DK								830 [32.68]	915 [36.02]
DN 100, EN flange PN 16	EV								830 [32.68]	915 [36.02]
DN 100, EN flange PN 40	DL								830 [32.68]	915 [36.02]
DN 100, EN flange PN 63	EW								830 [32.68]	915 [36.02]
DN 100, EN flange PN 100	DM								830 [32.68]	915 [36.02]

<sup>16)</sup>Connections without installation length are not possible or need manufacturer release. Please contact the manufacturer.



## SLIP ON, PROCESS CONNECTION DIM. + FACING ACC. EN 1092-1 FORM B INSTALLATION LENGTH IN MM [INCH]

Process connection <sup>17)</sup>	Code	TCM 0325	TCM 0650	TCM 1550	TCM 3100	TCM 5500	TCM 7900	TCM 028K	TCM 065K	TCM 230K
DN125, EN flange PN 16	EX									915 [36.02]
DN125, EN flange PN 40	DN									915 [36.02]
DN125, EN flange PN 63	EY									915 [36.02]
DN125, EN flange PN 100	DO									915 [36.02]
DN150, EN flange PN 16	DI									915 [36.02]
DN150, EN flange PN 40	DX									915 [36.02]

## EN FLANGE WELD NECK INSTALLATION LENGTH IN MM [INCH]

Process connection <sup>17)</sup>	Code	TCM 0325	TCM 0650	TCM 1550	TCM 3100	TCM 5500	TCM 7900	TCM 028K	TCM 065K	TCM 230K
DN 32, PN40 DIN 2635 – 1.4404 [AISI 316L] Type C Face	VO					460 [18.11]	460 [18.11]	625 [24.61]		
DN 32, PN64 DIN 2636 – 1.4404 [AISI 316L] Type E Face	VP					460 [18.11]	460 [18.11]	625 [24.61]		
DN 32, PN100 DIN 2637 – 1.4404 [AISI 316L] Type E Face	VQ					460 [18.11]	460 [18.11]	625 [24.61]		

## TRICLAMP INSTALLATION LENGTH IN MM [INCH]

Process connection <sup>17)</sup>	Code	TCM 0325	TCM 0650	TCM 1550	TCM 3100	TCM 5500	TCM 7900	TCM 028K	TCM 065K	TCM 230K
½" Triclamp	TA	220 [8.66]	220 [8.66]	250 [9.84]	250 [9.84]					
DN 25 Triclamp PN 16 DIN 32676	TL	210 [8.27]	210 [8.27]	240 [9.45]	240 [9.45]	460 [18.11]	460 [18.11]	625 [24.61]		

<sup>17)</sup>Connections without installation length are not possible or need manufacturer release. Please contact the manufacturer.



FEMALE THREAD  
INSTALLATION LENGTH IN MM [INCH]

Process connection <sup>18)</sup>	Code	TCM 0325	TCM 0650	TCM 1550	TCM 3100	TCM 5500	TCM 7900	TCM 028K	TCM 065K	TCM 230K
¼" NPT female thread	FJ	110 [4.33]	110 [4.33]	140 [5.51]	140 [5.51]					
¾" NPT female thread	FL	110 [4.33]	110 [4.33]	140 [5.51]	140 [5.51]	460 [18.11]	460 [18.11]			
½" NPT female thread	FK	110 [4.33]	110 [4.33]	140 [5.51]	140 [5.51]	460 [18.11]	460 [18.11]			
2" NPT female thread	FQ								880 [34.65]	
¼" G. female thread	FB	110 [4.33]	110 [4.33]	140 [5.51]	140 [5.51]					
⅜" G, female thread	FR	110 [4.33]	110 [4.33]	140 [5.51]	140 [5.51]					
¾" G, female thread	FC	110 [4.33]	110 [4.33]	140 [5.51]	140 [5.51]	460 [18.11]	460 [18.11]			
½" G, female thread	FA	110 [4.33]	110 [4.33]	140 [5.51]	140 [5.51]	460 [18.11]	460 [18.11]			

<sup>18)</sup>Connections without installation length are not possible or need manufacturer release. Please contact the manufacturer.



## **NORTH & SOUTH AMERICA**

AW-Lake Company  
2440 W. Corporate Preserve Dr. #600  
Oak Creek WI 53154 | USA  
+1 414 574 4300  
[sales@aw-lake.com](mailto:sales@aw-lake.com)  
[www.aw-lake.com](http://www.aw-lake.com)

## **ASIA PACIFIC & MIDDLE EAST**

KEM Küppers Elektromechanik GmbH  
Liebigstraße 5  
85757 Karlsfeld | Germany  
+49 8131 59391-0  
[info@kem-kueppers.com](mailto:info@kem-kueppers.com)  
[www.kem-kueppers.com](http://www.kem-kueppers.com)

## **EUROPE (ROW)**

KEM Küppers Elektromechanik GmbH  
Liebigstraße 5  
85757 Karlsfeld | Germany  
+49 8131 59391-100  
[sales@kem-kueppers.com](mailto:sales@kem-kueppers.com)  
[www.kem-kueppers.com](http://www.kem-kueppers.com)

## **CHINA**

KEM flow technology (Beijing) Co., Ltd.  
Rm. 906, Block C, Ruipu Office Bldg, No. 15  
HongJunYingNan Road  
Chaoyang District, Beijing 100012 | China  
+86 10 84929567  
[sales@kem-kueppers.com](mailto:sales@kem-kueppers.com)  
[www.kem-kueppers.cn](http://www.kem-kueppers.cn)